

August 8, 2012 Rev.2



**F90M SERIES
MULTI-PURPOSE MANUAL
MACHINING CENTERS**

MACHINE SERIAL NUMBER

OPERATIONS AND MAINTENANCE
MANUAL



MANUFACTURED BY:

ROTTLER MANUFACTURING COMPANY
8029 South 200th Street
Kent Washington 98032
USA

Phone: (253) 872-7050
Fax: (253) 395-0230
Website: <http://www.rottlermfg.com>

NOTE: WHEN ORDERING REPLACEMENT PARTS,
PLEASE GIVE THE MODEL AND SERIAL NUMBER.
SEND DIGITAL PHOTO OF PART TO EXPIDITE ORDER.
ORDER BY PART NUMBER.

THERE IS A MINIMUM ORDER OF \$25.00

Manual Chapters:

- Chapter 1** Introductions/Safety/Installation
- Chapter 2** Control Definition
- Chapter 3** Operating Instructions
- Chapter 4** Maintenance
- Chapter 5** Troubleshooting
- Chapter 6** Machine Parts
- Chapter 7** Options (Separate Manual)
- Chapter 8** MSDS

Individual Chapter Table of Contents are at the front of each Chapter

Chapter 1 Contents

Introduction / Safety / Installation:	2
Introduction:	2
Description:	2
Limited Warranty:	2
Safety Information:	3
Safety Instructions for Machine Use	3
Electrical Power:	4
Machine Operator:	5
Emergency Procedure:	6
Computer and Controller System Safety:	6
Machine Installation:	7
Location:	7
Unpacking:	7
Column Hold Down:	7
Leveling:	7
Air Supply:	9
Power Supply:	10
Grounding:	10
F90M Customer Responsibility prior to arrival of Rottler Technician:	11
Approved methods to install the spindle base when required:	11
Spindle Base Assembly with Column:	12
Spindle Base Assembly with Column:	13
F90M Using Overhead Bridal with Chains:	14
F90M Using Fork Lift & Angle Steel Brackets:	15
F90M Clearance Heights:	17
Rottler F90 Series Foundation and Hold Down Requirements	18
F99M Hold-down / Jacking Bolt Locations:	19
F98M Hold-down / Jacking Bolt Locations:	20
F90M Hold-down / Jacking Bolt Locations:	21

Introduction / Safety / Installation:

Introduction:

The manual is arranged in sections as listed in the table of contents.

We suggest that the new user of the F90M first read the CONTROL DEFINITIONS to get an idea how the machine operates.

The Operating Instructions chapter should be read in order to familiarize the user with the actual button pushing sequences required to carry out a job. These chapters in the manual should be considered an introduction. As the operators of the F90M series machines gain experience with using the different functions of the machine, complicated setups and programs will make more sense.

The rest of the manual contains information and part number reference on fixtures, cutting tools, and machine maintenance. The operator should read and become familiar with these areas as well.

Description:

The model F90M machine is a precision, single point boring, and high-speed surfacing unit. The machine can be equipped with tooling and accessories for surfacing and re-boring most American passenger car and truck engines, In-lines, as well as 90 and 60 degree V-types.

F90 machines can be easily tooled, to machine a wide range of engines, including European and Asian engines, also, the machine can be easily adapted to perform other boring and surfacing operations.

The machine is designed, to maintain alignment of cylinder bores, and cylinder head, deck surfaces to the pan rails and main bearing bore locations, as was done in the original factory machining. This overcomes the many inaccuracies and out-of-alignment problems associated with clamping portable boring bars to the cylinder head surface of blocks.

Convenient controls, fast block clamping, precise 3 axis CNC positioning and clamping, means considerable savings in floor to floor time, and operator involvement.

Change over or resetting time required to set up V-type or in-line engines is a minimum, making this machine highly suited to the jobber shop where engines cannot be run through in model lots.

All feeds and rapid travels are power operated and controlled from the control panel.

Limited Warranty:

Rottler Manufacturing Company, Model F90M parts and equipment is warranted as to materials and workmanship. This limited warranty remains in effect for one year from the date of delivery, provided the machine is owned and operated by the original purchaser and is operated and maintained as per instructions in this manual.

The factory will repair or replace, at their option, tools proven to be defective.

We accept no responsibility for defects caused by external damage, wear, abuse, or misuse, nor do we accept any obligation to provide compensation for other direct or indirect costs connected to cases covered by the warranty.

Freight charges on warranty items (non-air shipment only) will be paid by Rottler Manufacturing, for a period of 60 days only, from date of installation or set-up by a qualified service technician or sales rep. Freight charges after the 60-day period are the customer's responsibility.

Safety Information:

For Your Own Safety Read This Instruction Manual Before Operating This Machine.



This is the safety alert symbol. It is used to alert you to potential personal injury hazards. Obey all safety messages that follow this symbol to avoid possible injury or death.



DANGER indicates an imminently hazardous situation which, if not avoided, will result in death or serious injury.



WARNING indicates a potentially hazardous situation which, if not avoided, could result in death or serious injury.



CAUTION indicates a potentially hazardous situation which, if not avoided, may result in minor or moderate injury.



CAUTION used without the safety alert symbol indicates a potentially hazardous situation which, if not avoided, may result in property damage.



This machine is capable of causing severe bodily injury.

**Safety Instructions for Machine Use**

ONLY A QUALIFIED, EXPERIENCED OPERATOR SHOULD OPERATE THIS MACHINE. NEVER ALLOW UNSUPERVISED OR UNTRAINED PERSONNEL TO OPERATE THE MACHINE. Make sure any instructions you give in regards to machine operation are approved, correct, safe, and clearly understood.

KEEP GUARDS IN PLACE and in proper working order.

KEEP WORK AREA CLEAN. Cluttered areas and benches invite accidents.

KEEP CHILDREN AND VISITORS AWAY. All children and visitors should be kept a safe distance from work area.

WEAR THE PROPER APPAREL. DO NOT wear loose clothing, gloves, rings, bracelets, or other jewelry which may get caught in moving parts. Non-Slip foot wear is recommended. Wear protective hair covering to contain long hair.

ALWAYS USE SAFETY GLASSES. Also use face or dust mask if cutting operation is dusty. Everyday eye glasses only have impact resistant lenses, they are NOT safety glasses.

DO NOT OVER-REACH. Keep proper footing and balance at all times.

USE THE RECOMMENDED ACCESSORIES. Consult the manual for recommended accessories. The use of improper accessories may cause risk of injury.

CHECK DAMAGED PARTS. Before further use of the machine, a guard or other part that is damaged should be checked to determine that it will operate properly and perform its intended function. Check for alignment of moving parts, breakage of parts, mounting, and other conditions that may affect its operation. A guard or other part that is damaged should be properly repaired or replaced.

NEVER OPERATE A MACHINE WHEN TIRED, OR UNDER THE INFLUENCE OF DRUGS OR ALCOHOL. Full mental alertness is required at all times when running a machine.

IF AT ANY TIME YOU ARE EXPERIENCING DIFFICULTIES performing the intended operation, stop using the machine! Then contact our service department or ask a qualified expert how the operation should be performed.



No list of safety guidelines can be complete. Every shop environment is different. Always consider safety first, as it applies to your individual working conditions. Use this and other machinery with caution and respect. Failure to follow guidelines could result in serious personal injury, damage to equipment or poor work results.

Electrical Power:



All electrical power should be removed from the machine before opening the rear electrical enclosure. It is recommended that the machine have a electrical LOCK-OUT device installed.

Make sure all electrical equipment has the proper electrical overload protection.

In the event of an electrical short, grounding reduces the risk of electric shock by providing a path of least resistance to disperse electric current.



Electrocution or a fire can result if the machine is not grounded correctly. Make sure the ground is connected in accordance with this manual. DO NOT operate the machine if it is not grounded.



No single list of electrical guidelines can be comprehensive for all shop environments. Operating this machinery may require additional electrical upgrades specific to your shop environment. It is your responsibility to make sure your electrical system comply with all local codes and ordinances.



When boring the machine is capable of throwing metal chips over 10- feet from the cutting area. Always use the guards. Eye protection must be worn at all times by the operator and all other personnel in the area of the machine.



The F90M operates under computerized control and, as is all computerized equipment, and is susceptible to extraneous electrical impulses internally for externally produced. The machine may make moves out of the operator control at any time. The operator should work in and around the machine with caution at all times.

The operator and nearby personnel should be familiar with the location and operation of the Emergency Stop Button.

Make sure all electrical equipment has the proper overload protection. The F90M should have **a fully isolated** power supply to prevent damage and uncontrolled movement of the machine. If the F90M is on the same power lines that are running to other electrical equipment (grinders, welders, and other AC motors) electrical noise can be induced into the F90M electrical system. Electrical noise can cause the controller to see false signals to move. Not supplying a fully isolated supply to the machine may void factory warranty. Refer to the Power supply section later in this chapter for voltage and amperage requirements of the F90M.

Machine Operator:

The operator of the F90M should be a skilled machinist craftsman who is well versed in the caution, care, and knowledge required to safely operate metal cutting tools.

If the operator is not a skilled machinist he/she must pay strict attention to the Operating Instructions outlined in this manual, and get instruction from a qualified machinist in both production and operation of this machine.

The F90M machines have the following areas of exposed moving parts that you must train yourself to respect and stay away from when they are in motion:



Cutting Tool Area – Any operation involving hands in the cutter head area, such as inspection or alignment of the cutter head or tools, changing Centering Fingers, tool insertion, and removal, cutter head changes, and size checking etc. requires the machine to be in Neutral.



Machining – Eye protection must be worn during all operations of the machine. Hands must be kept completely away from the cutter head. All chip guards must be in position during machine operations.



Work Loading and Unloading – Carefully develop handling methods of loading and unloading work pieces so that no injury can result if hoist equipment or lift connection should fail. Periodically check lift components for damage that may cause failure.



Machine Maintenance – Any machine adjustment, maintenance or parts replacement absolutely requires a complete power disconnection from the machine, ***this is an absolute rule.***

Emergency Procedure:

Assuming one of the following has occurred: tool bit set completely off size, work piece or spindle base not clamped, spindle is not properly centered, and these mistakes will become obvious the minute the cut starts

PRESS THE EMERGENCY STOP BUTTON (on the front control panel) IMMEDIATELY!

Find out what the problem is; return the spindle to its up position without causing more damage. To restart the machine, turn the Emergency Stop Button CW until the button pops out
Be alert to quickly stop the machine in the event of a serious disruption of the boring process either at the top or bottom of the bores.

“REMEMBER” metal cutting tools have the speed and torque to severely injure any part of the human body exposed to them.

Computer and Controller System Safety:

The computer and controller are located in the main rear electrical enclosure. This unit is a full computer, running Windows 7 64 Bit operating system. Contact the factory if more information on the computer system is required.

IMPORTANT: The computer in this machine has the ability to connect to the World Wide Web via Ethernet or Wireless using a USB wireless (Wi-Fi) adapter. Updating the Rottler software should **ONLY** be done when directed to do so by a Rottler service technician. Updating Rottler Software when not directed by Rottler personnel will result in a non-operational machine.

The machine should be hooked up to the internet anytime it is on. The software on the machine will automatically connect to our server to send back useful information on machine status.

The Auto Update for the Windows Firewall (Security) and Windows Defender (Anti-Virus) is turned on. The computer will automatically download the updates and then install them when the computer is shut down every Friday night.

Any “IT” personnel should ALWAYS get approval from Rottler before doing ANYTHING on the computer.



DANGER

This machine is capable of causing severe injury or death. Doing any of the following without Rottler’s direct consent may cause severe injury or death.



WARNING

Downloading ANY program from the Internet or by other means when not directed by Rottler is prohibited and will result in the machine warranty being NULL and VOID.



WARNING

Downloading any program or changing any Rottler or Computer settings may cause the machine and/or software to become unstable. DO NOT install ANY screen saver, Anti-Virus, Spyware or any type of Security software on the computer. This could create a hazardous environment for the operator and personnel around the machine. Performing any of the above will also result in the machine warranty being NULL and VOID.



DO NOT connect any type of external hardware to the computer via USB or any other means. Do not install any type of Device Driver. This could create a hazardous environment for the operator and personnel around the machine. Performing any of the above will also result in the machine warranty being NULL and VOID.

Machine Installation:

Location:

The productivity of this machine will depend a great deal on its proper initial installation. Pay particular attention to the means by which work pieces are lifted into the machine as well as the material handling to and from other operations in your shop.

The proper loading arrangement and area location for your F90M machine is extremely important.

A slow travel (6' to 10' per minute) power hoist, operated from either a bridge crane or a jib crane arrangement works very well. Verify the hoist has a rating that exceeds the load being lifted.

For the shop where large production runs are anticipated, the work pieces should be directly loaded and unloaded from a conveyer. If this is not the case we recommend considerable attention be given to the crane so that it covers an adequate area, to allow the operator to back up and remove work pieces without creating a dangerous, cluttered work area.

Unpacking:

Use care in removing the crate materials from the machine. Be careful not to use force on any part of the machine.

Remove the toolbox, parallels and optional equipment from the machine. Completely clean these articles as well as the rest of the machine with solvent. Rust inhibitor was applied, at the time of shipment. Any of this left on the machine, will allow cast iron dust to collect in that area, which could cause premature wear.

Column Hold Down:

The machine was shipped with the column held in place with chains and turnbuckles to the Main bed. Do not attempt to move the machine under power until these restraints have been removed.

Leveling:

Located in the bottom of the main base are the leveling and tie down screws. If care is taken, the main base can be leveled extremely accurately. Start by placing the jacking pads under the jacking screws. Adjust the jacking screws so the lowest point of the main base is at least 1/4" off the jacking pad. Make sure all the jacking screws are touching their jacking pads. Use a precision machinist's level, and check the base at several points to get an idea where the high and low spots are, adjust evenly where necessary. Start with the back way surface. With your precision level, level the back way in the lengthwise direction to .0005" per foot. Take the readings approximately mid way between the jacking points.

Use a precision metal support to span the distance between the front and rear parallels. (Support must be parallel within .0005" in its length). Take readings over every jacking bolt and level within .0005" over the length of the base. Be sure to use the jacking points down the middle of the main base.

Recheck the way surfaces for level. Now check the machine table. Using the front jacking screws level the table within .0005" in both directions.

Be sure that all jacking bolts have approximately equal weight on them. As you go leveling the base snug the tie down bolts to help hold the main base in place. Recheck all areas of the main base for level.

Air Supply:

It is very important the air source for the F90M machine be moisture free. Water and oil in the line will result in early cylinder and valve failure. The factory recommends installing a water trap at the machine.

Attach a 100 P.S.I. air source to the appropriate intake in the small enclosure located on the left rear of the machine near the bottom.

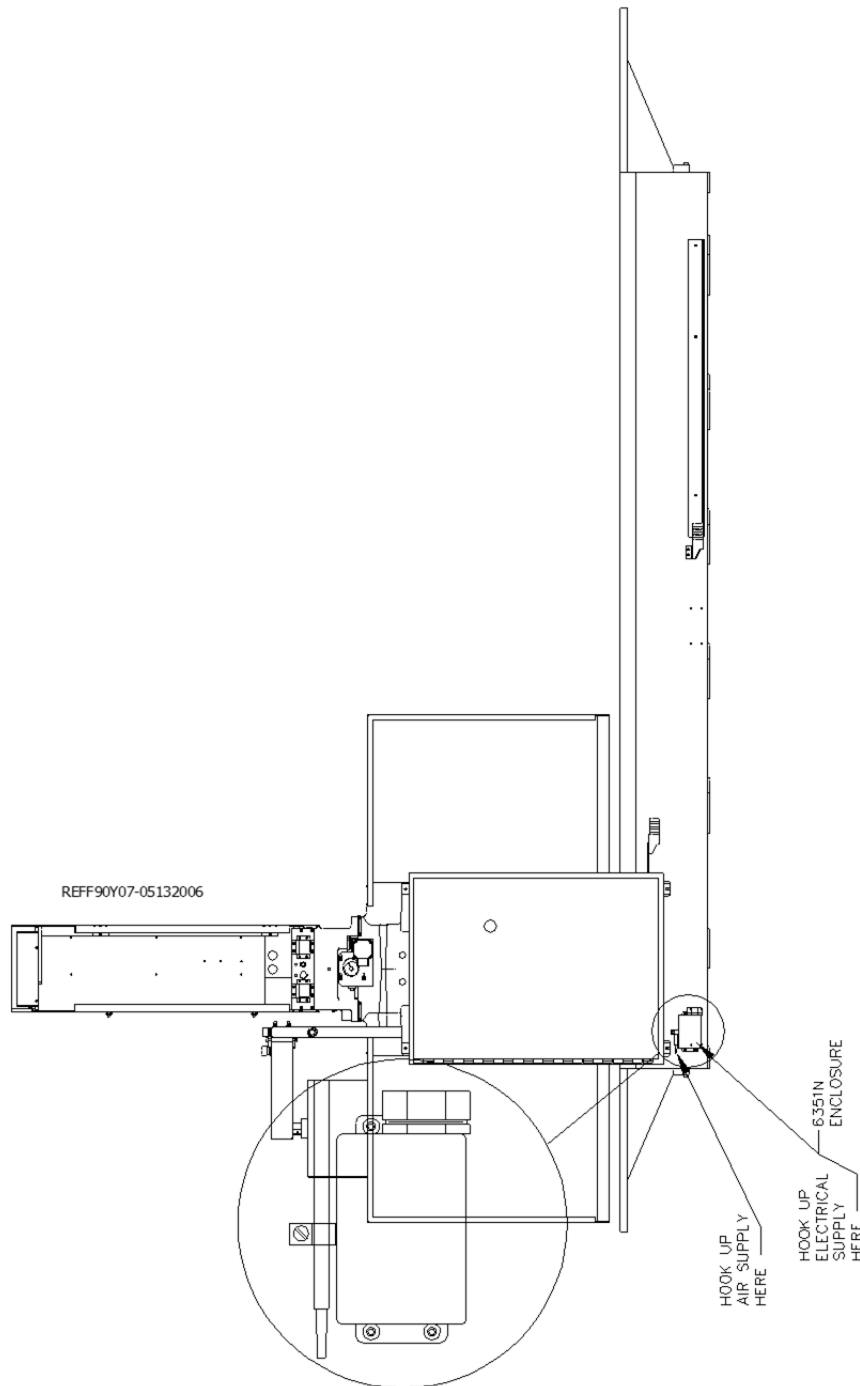

Power Supply:

This machine has the following power requirements:

208 to 240 VAC
 Three Phase
 50 or 60 Hertz
 60 amps

See illustration below for correct connection of “measured” incoming power. Connect three phase wiring to the electrical box located on the back of the machine in the lower right hand corner. See previous illustration. If a “high leg” exists, this must be at Line 3 **Important: Electrically connect in accordance with national and local electrical codes.**

Note: For voltages over 240 VAC (380 – 440 VAC) a factory supplied transformer needs to be purchased with the machine.

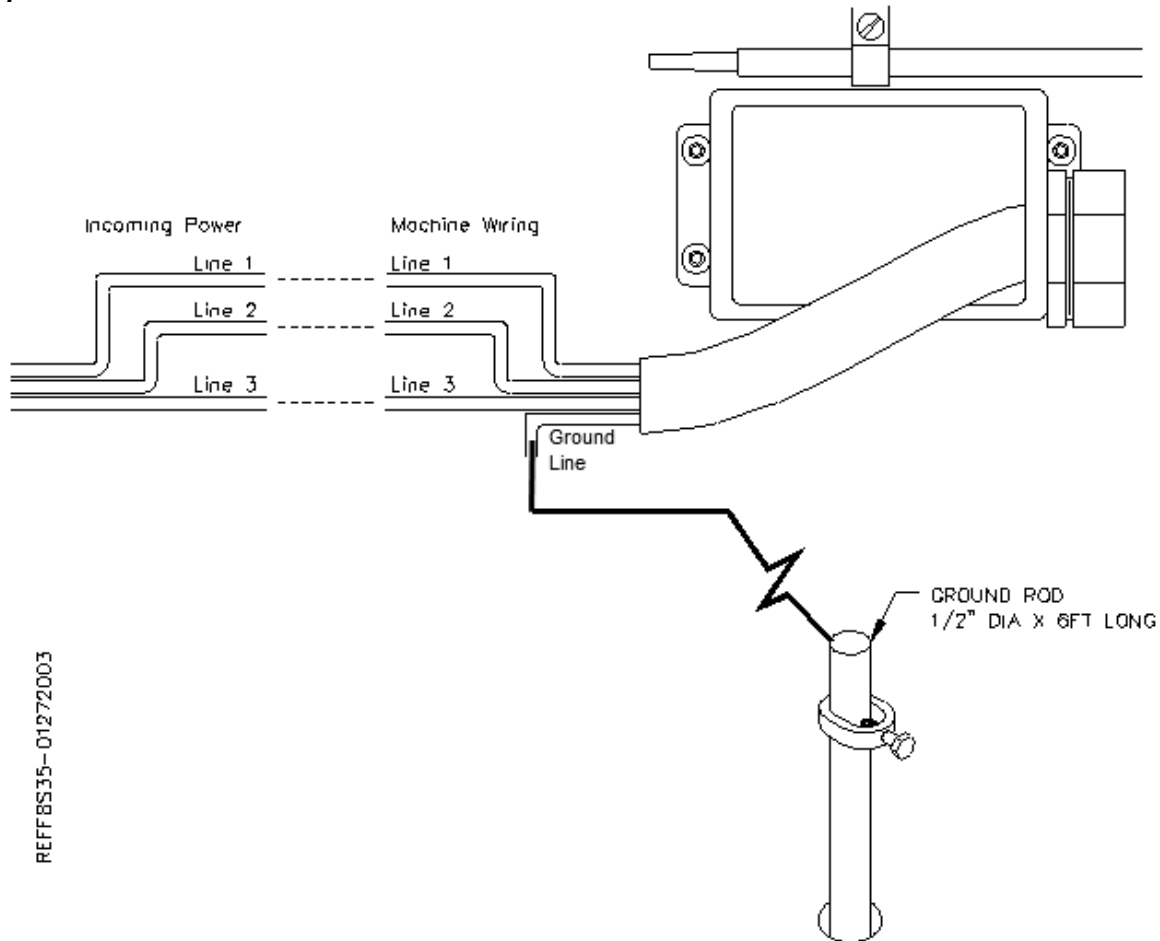
**Grounding:**

This machine must be connected to a good earth ground rod. A 6 foot, 1/2" diameter, 15 OHM, Copper grounding rod driven into the earth next to the machines is preferred. Not providing a grounding rod could void factory warranty.

F90M Customer Responsibility prior to arrival of Rottler Technician:

Remove machine from truck. Weight: F90M is 23,000 lbs.

Provide foundation and hold down bolt system.

Open the door on the spindle base. There are two threaded rods going through the spindle base to the machine table. Remove the rods and the nuts from the machine.

Remove fixturing and misc. from machine and clean.

Install machine on foundation with jack pads under jacking bolts.

Install hold down nuts and bolts.

Rough level machine.

Connect electricity, (3 phase, 208 to 240 VAC with a 60 amp breaker and an isolated ground) to machine.

Connect air supply of proper pressure and capacity (95/100 PSI, 3 C.F.M) to machine. (Note: air supply must be free from water and oil as this will damage electrical and air components.)

Customer should attempt to have junk work piece for operator training.

Operator should read the manual before training begins.

Fill out customer portion of the checklist in this packet to properly qualify warranty on the equipment.

Approved methods to install the spindle base when required:

1. Remove the sheet metal cover, #9006, from the rear of the spindle base.
2. Locate and set aside the aluminum ballscrew nut mount plate, #9001D
3. Remove the column top rails, #9024B, and the left side rail, #9024B.
4. When lifting the spindle unit, keep in mind the front to back center of gravity is located approx. 12" from the front end, and has a tendency to fall forward. The spindle unit weighs 2,500 lbs
5. Carefully lift the spindle base using one of the approved methods described below. If using the fork lift angle steel brackets, temporarily support, and unbolt the pendant arm from the column, to allow clearance for the right angle steel bracket when setting the spindle base in place.
6. Check column top and spindle base bottom for rust and nicks.
7. Clean and stone as required.
8. Lightly oil the column top way surface, and the spindle base turcite ways, using # 68 way oil.
9. Carefully set the spindle base in place, while at the same time, routing the proximity switch wires up through the opening of the spindle base, in the area of the ballscrew nut mount plate, #9001D. Use the right side rail, #9024D, as a guide for placement of the spindle base.
10. Remove the fork lift angle steel brackets.
11. Locate the guide rail gibs, #9024A (6) and the spring washers, #9024E (24).
12. Install the spring washers in guide rails per the drawing enclosed with the washers (also shown below). Install the gibs, #9024A.
13. Install the left side guide rail, #9024B. The top of the guide rail (surface A) must be .035" above the way surface of the spindle base (surface B). Also check the right side guide rail for proper dimension. Torque bolts to 80 ft. lbs.
14. Install the left and right, top rails, #9024B. Torque bolts to 80 ft. lbs.
15. Install the left, #9110A, and right, #9110, way covers, making sure to route the oil line through cover and securely connected to the fitting(s)
16. Install the ballscrew nut mount plate, #9001D. Torque to 50 ft lbs.
17. Route the proximity switch wires down through the right side (facing the front of the machine), cable track, at the rear of the spindle base.
18. In the electrical enclosure on the back of the column, there are 3 clear 1/8" oil lines, connected together by a tee. Discard the tee and route the lines up through the right side (facing the front of the machine), cable track, up to the spindle base. Connect these to the fittings in the spindle base. Be sure to connect # 5 to # 5 line. Connect the 2 remaining lines in any order.
19. Install the sheet metal cover, #9006, at the rear of the spindle base.

Spindle Base Assembly with Column:

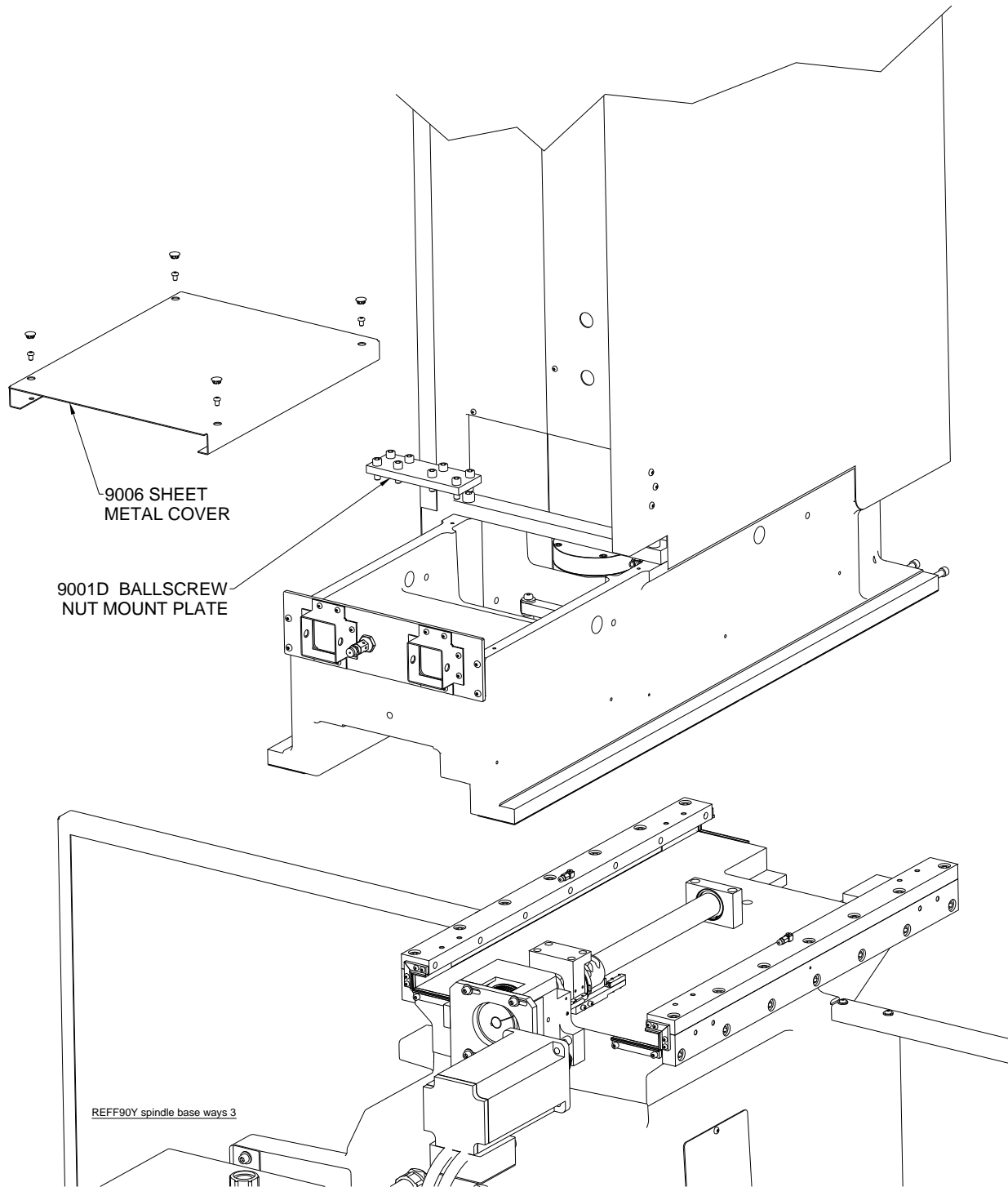

Spindle Base Assembly with Column:

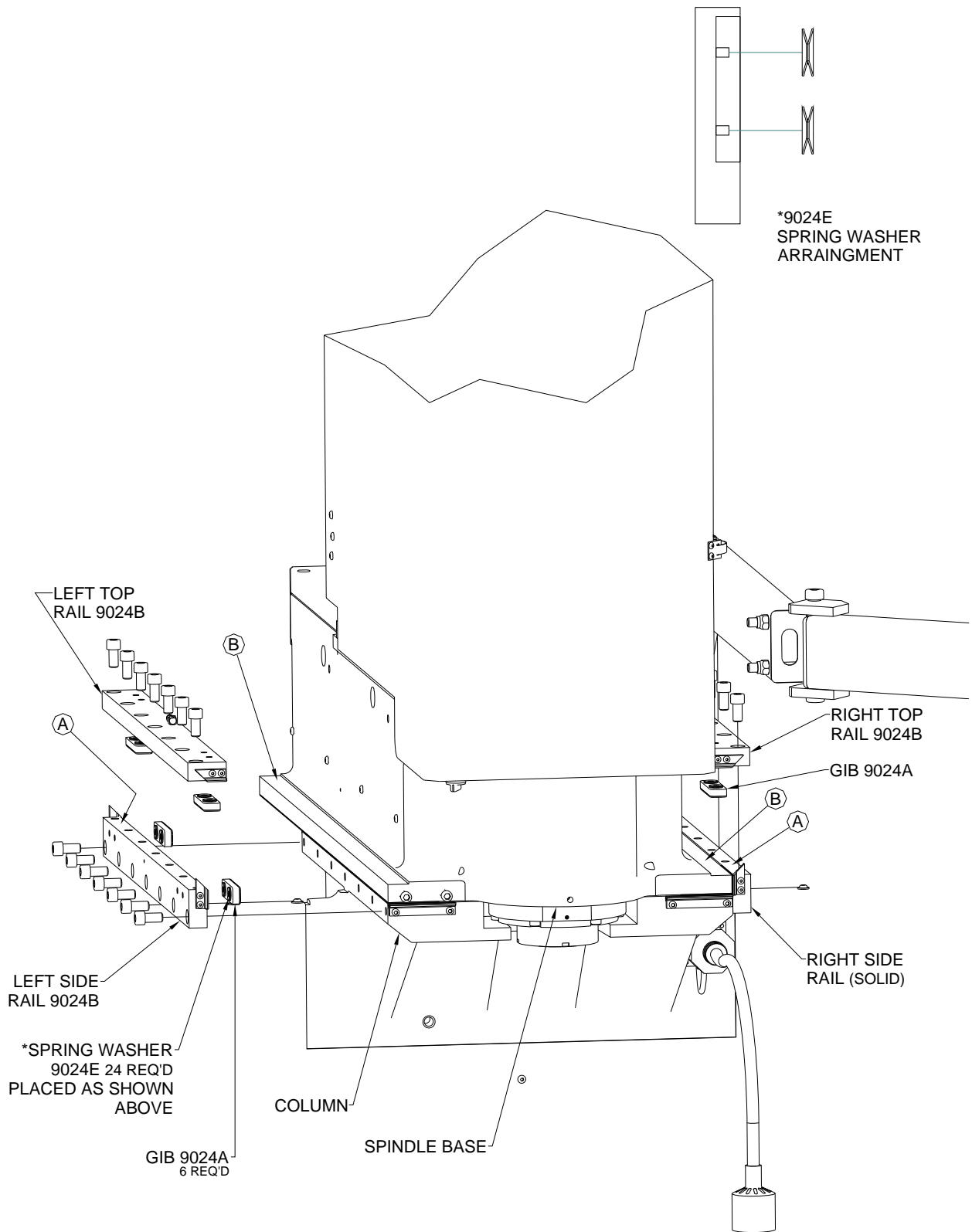

F90M Using Overhead Bridal with Chains:

Connect the three chains, one at the rear of the spindle base and one each on front left and right side. Use a chain or rope to connect the two front chains at the top of the spindle unit to prevent it from falling forward.

Be careful to watch clearance of all items.

Lift spindle unit into place. Install guide rails as described above.

Remove bridal and chains from spindle unit.

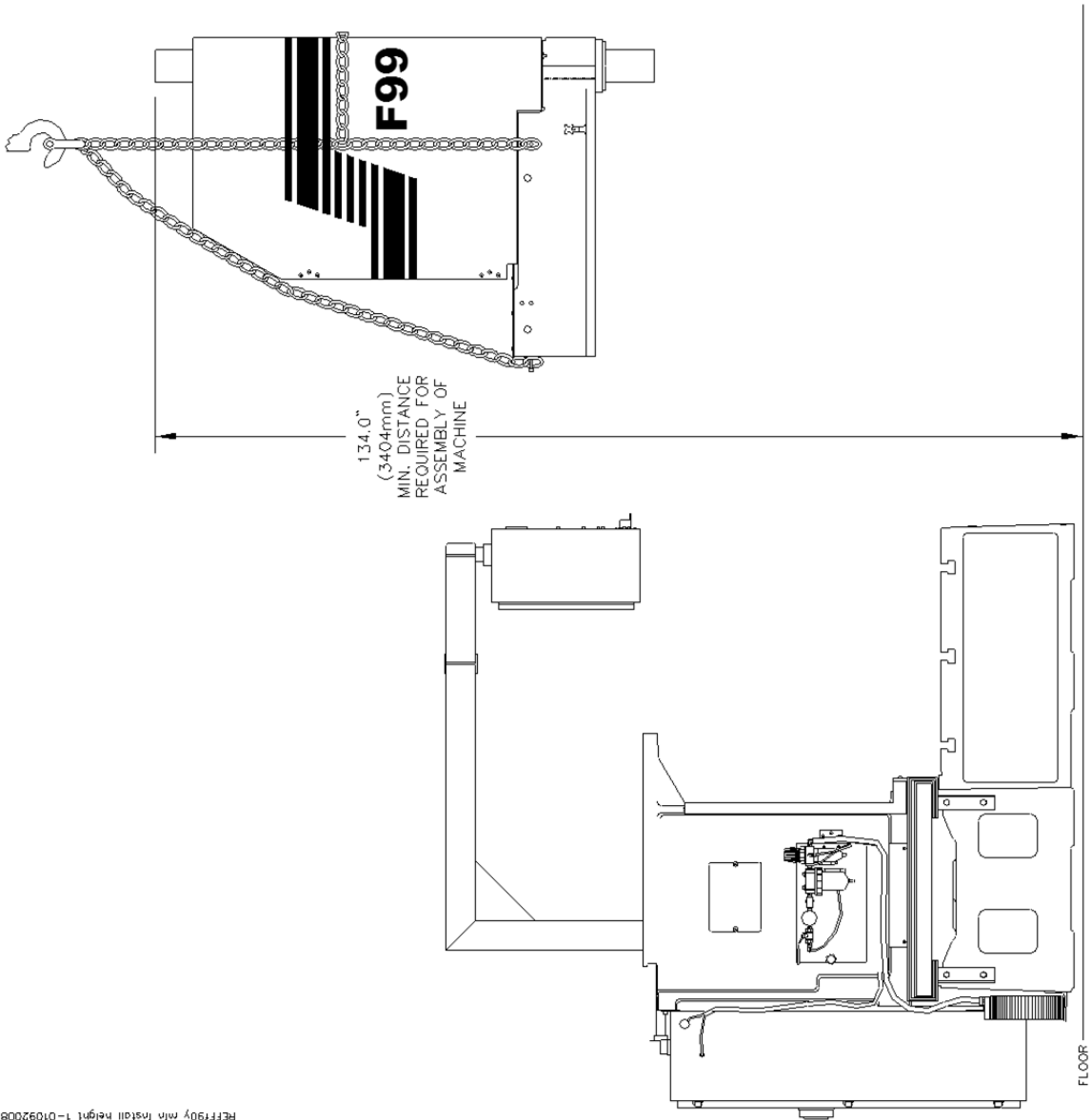

REF F90y min install height 1-01092008

F90M Using Fork Lift & Angle Steel Brackets:

Bolt brackets to each side of the spindle base.

Use large C-clamps to clamp the fork lift forks to the angle iron brackets. This will prevent any accidental slips.

Loosen $\frac{1}{2}$ 13 x 3 $\frac{1}{2}$ Inch bolts on pendent arm to allow it to be moved out of the way.

Use a forklift to lift the spindle unit onto the column.

Be careful to watch clearance of all items.

Install guide rails as described above.

Remove angle iron brackets from spindle base.

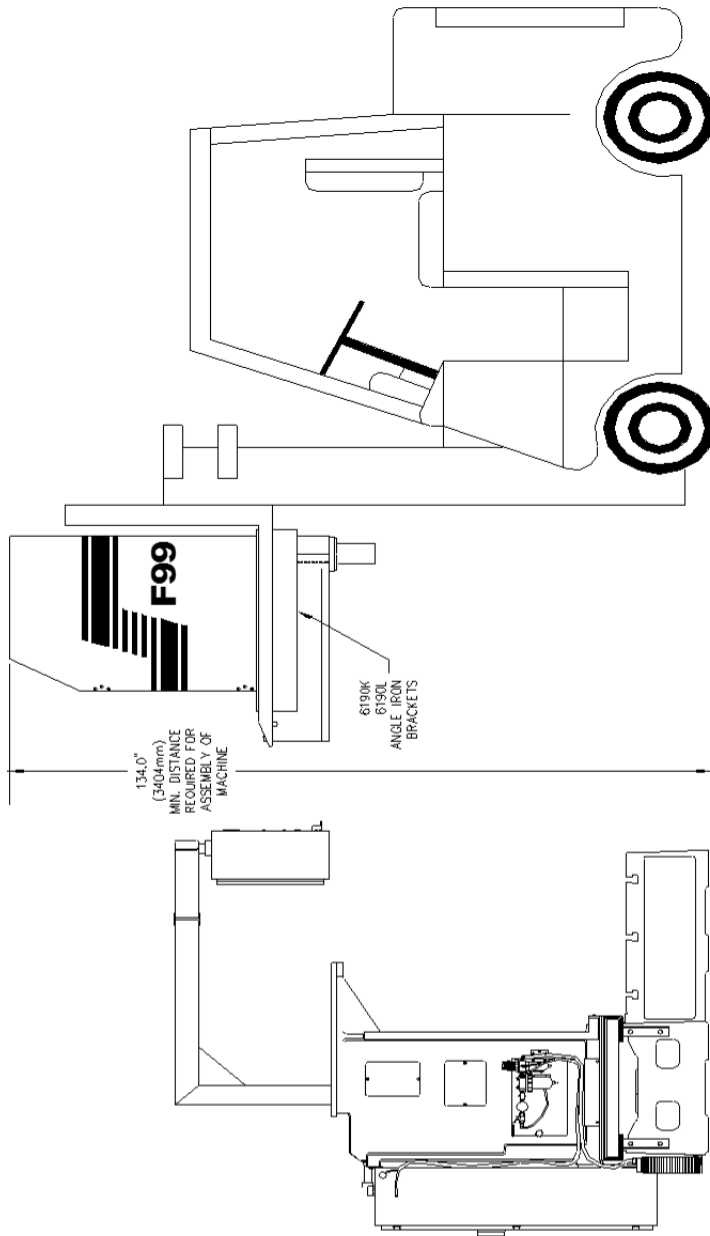

REF 990 with height height 2 01092008

F90M Clearance Heights:

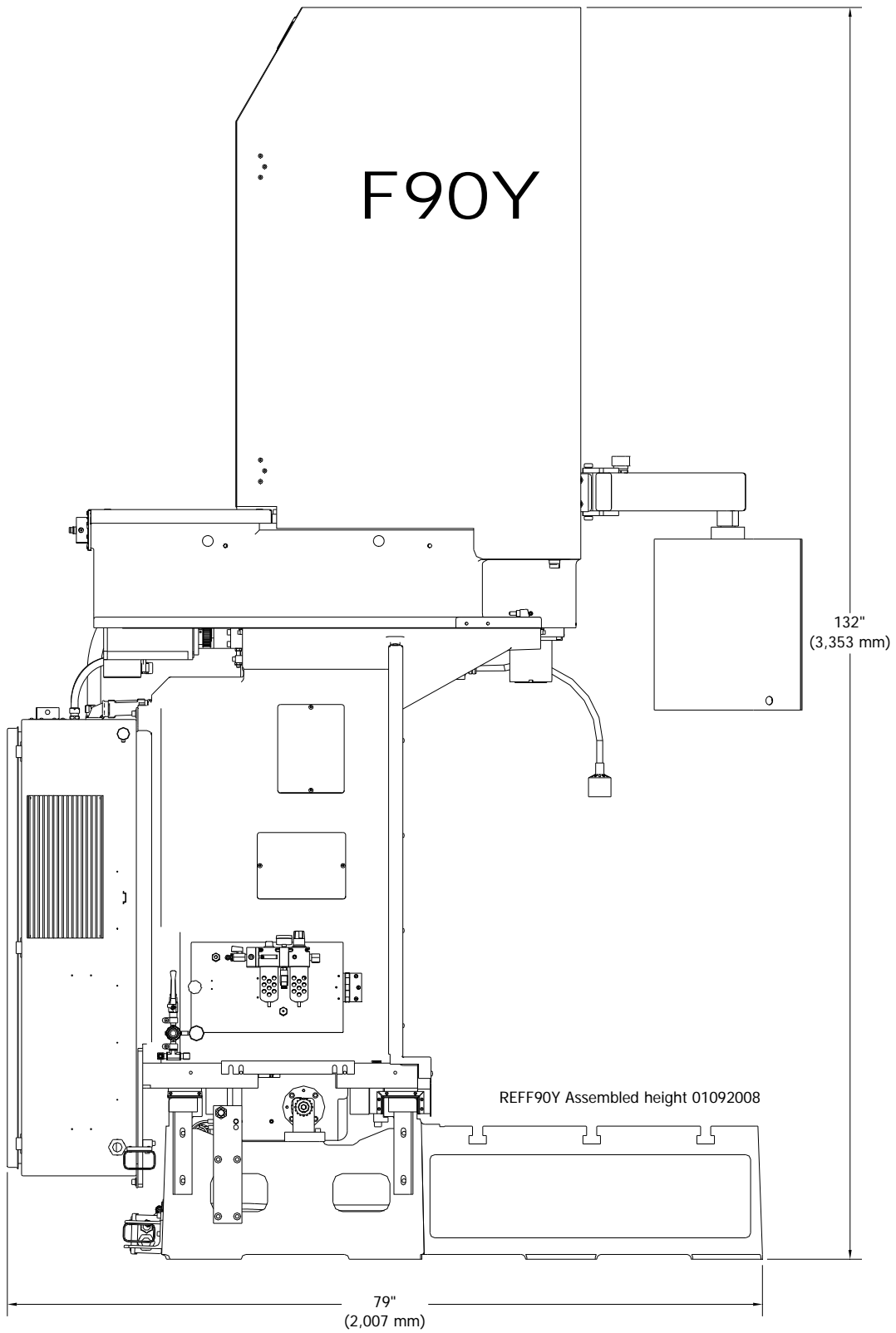

Rottler F90 Series Foundation and Hold Down Requirements

Rottler machines require a good concrete foundation and hold down system. It is not recommended to install a machine on a cracked floor or over an expansion joint. The layout/position of the hold down holes can be found on the foundation drawings below.

There are two methods commonly used by customers:

1. Drill the concrete floor as per drawing layout before arrival of machine.
2. Place machine, mark floor thru holes in machine base, move machine away then drill the floor.

The machine is provided with jacking bolts and steel pads to place between the jacking bolts and floor. For shipping, the steel pads are packed in a separate box and marked with yellow/black tape so the box is clearly visible. This allows the machine to be unpacked and removed from the shipping crate, placed on the floor on these steel pads without opening the accessory crates. When placing the machine on the jacking bolts, ALWAYS rough level to be sure that the weight of the machine is evenly distributed over all the jacking bolts.

Rottler recommend Hilti products as per attached list. $\frac{3}{4}$ " (20mm) diameter X 12" (300mm) long studs are recommended. Drill floor approx 7" (180mm) deep with 1" (25mm) drill. As it is difficult to drill concrete exactly on center, it is recommended to drill a pilot hole. After drilling and before injecting epoxy, it is also recommended to move the machine into place and make sure all studs fit thru the holes in the base and travel all the way down into the holes so that approx 5" (130mm) protrude out of the floor. The machine may have to be moved a small amount to allow all studs to fit. Once this is checked, the studs can be removed then the epoxy injected into the bottom of the holes. Make sure all dust is vacuumed out of the holes before the epoxy is injected. Ensure that the epoxy is injected starting at the bottom of the holes to be sure the stud has maximum contact with the epoxy. The size of the holes will determine how much epoxy to inject into the holes before fitting the studs. On average, $\frac{1}{2}$ to $\frac{2}{3}$ of the hole should be filled with epoxy before the stud is installed. Be sure when the stud is installed, that the epoxy fills the hole to the top. Fit the washer and nut and tighten lightly to align the stud then allow the epoxy 24 hours to harden ready for leveling and final anchoring.

The column is tied down with chains for transport, if it is required to move the column to help with installation of the hold down system, the column tie downs can be removed and manually turn the horizontal ball screw nut by hand to move the column sideways. Be sure that the sideways are clean and lubed under the column before moving.

F99M Hold-down / Jacking Bolt Locations:

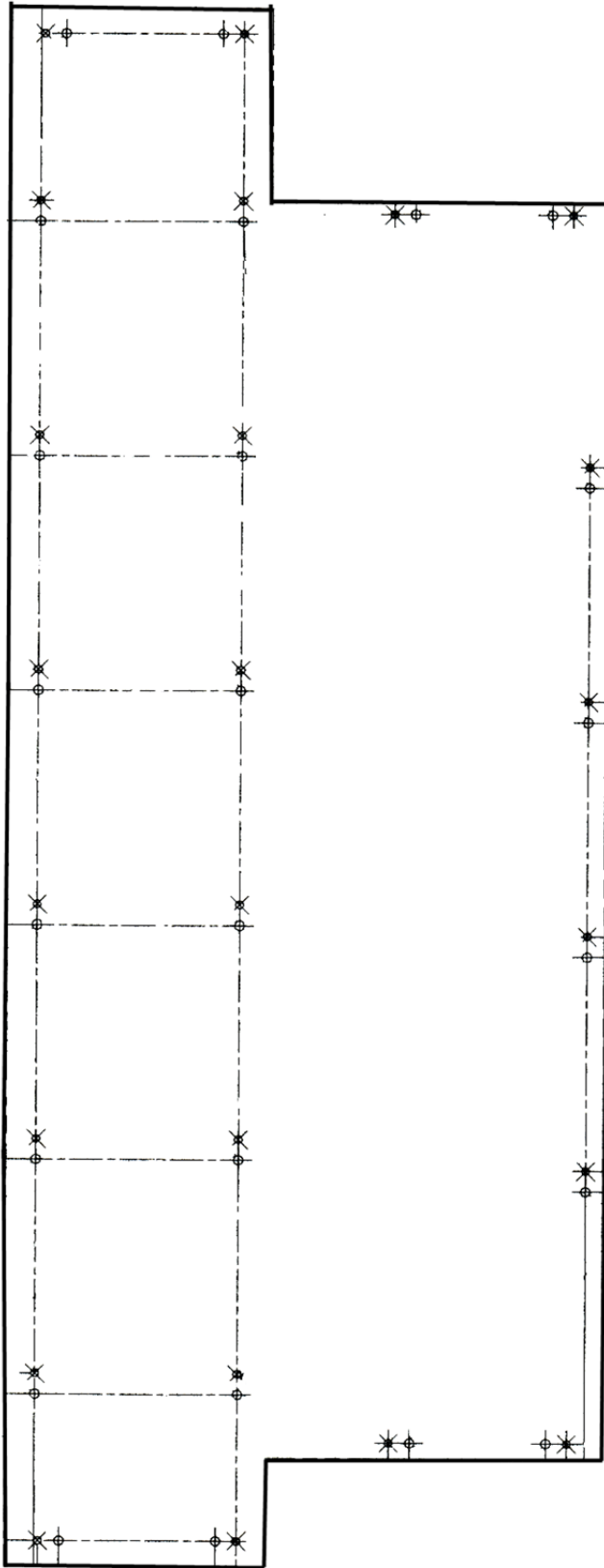

F98M Hold-down / Jacking Bolt Locations:

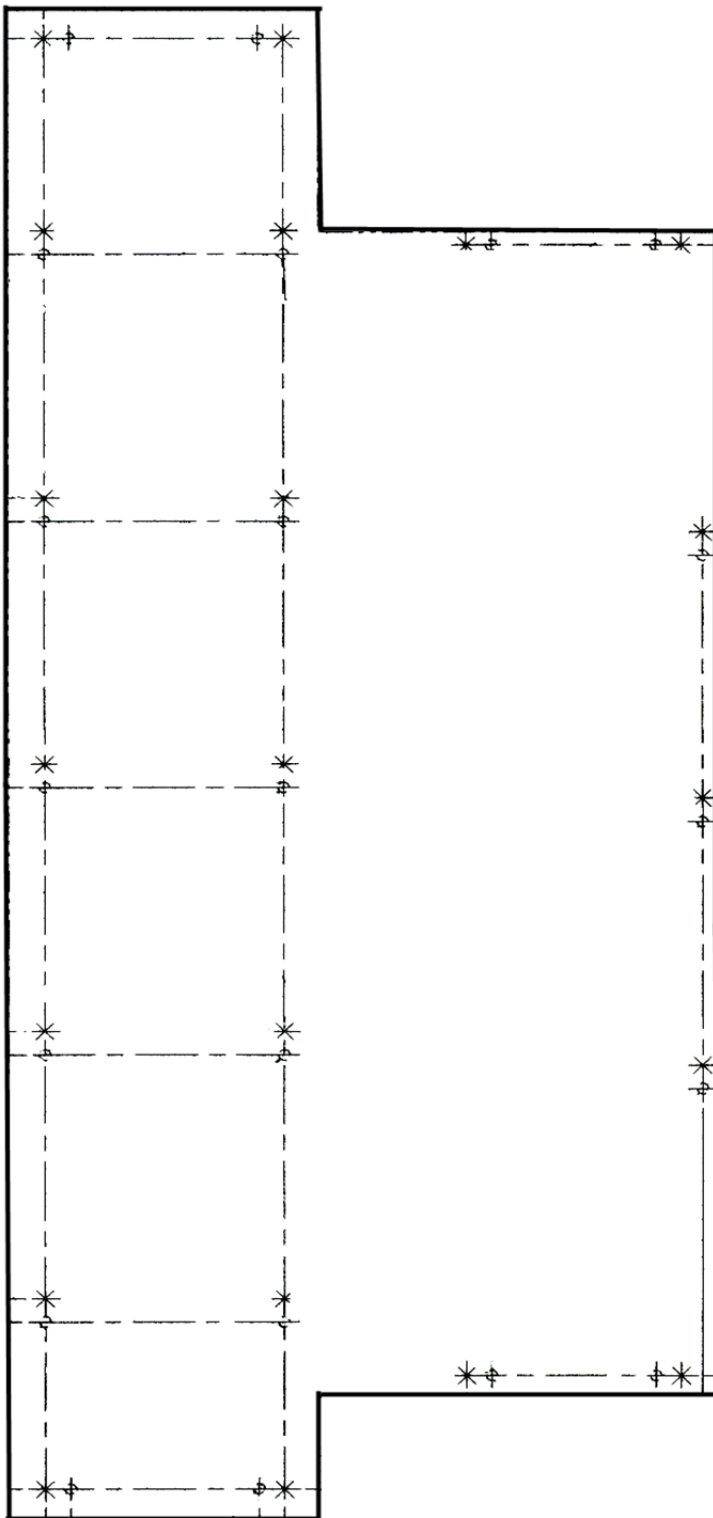

F90M Hold-down / Jacking Bolt Locations:

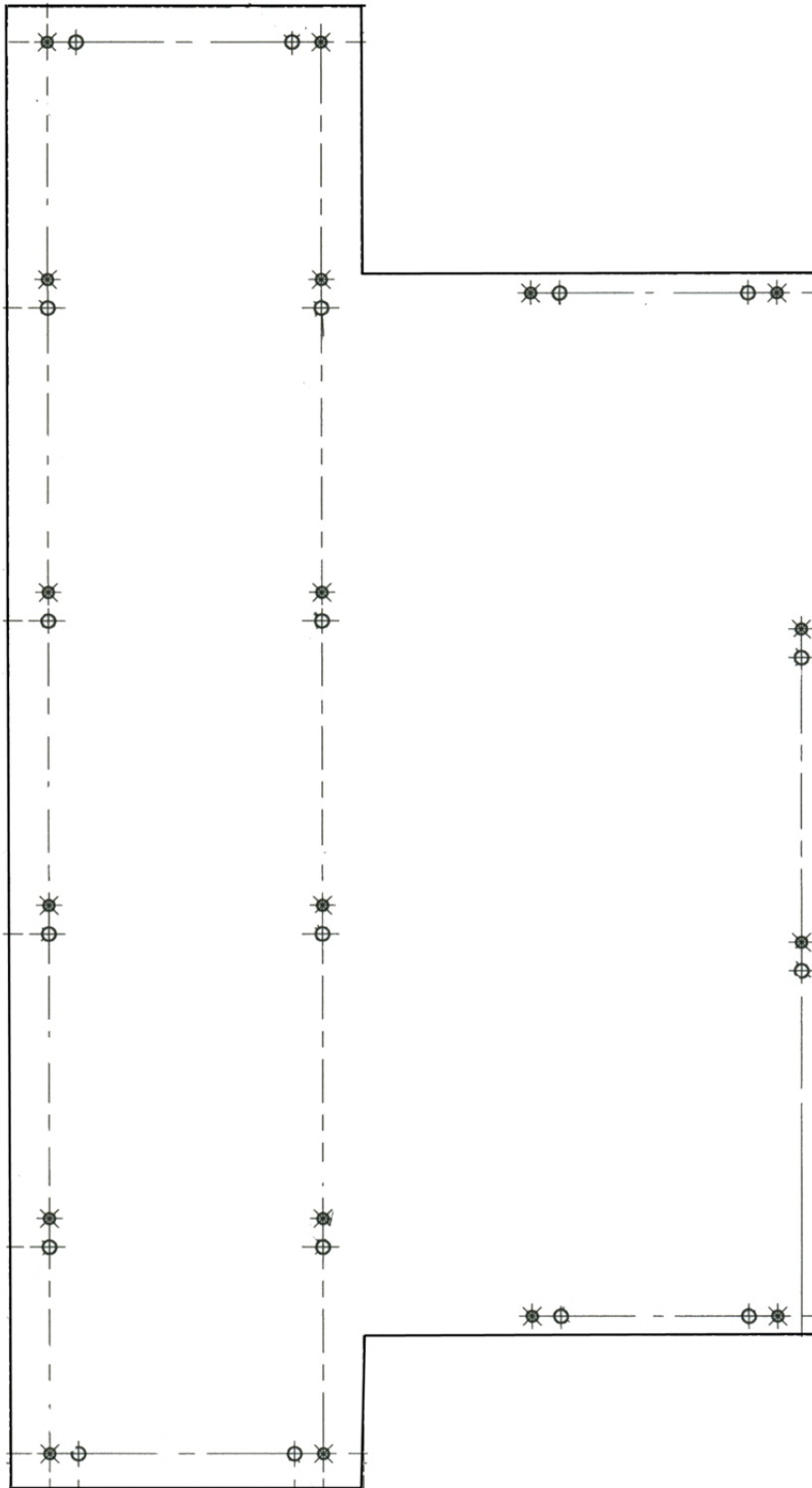

Chapter 2 Contents

Control Definitions:	2
Computer and Controller System Safety:	2
Master Power On/Off Switch:	2
Initialization Screen:	4
General Information:	4
Home:	4
Program Select:	4
New:	5
Options:	5
Delete:	5
Mode Select:	6
New:	6
Std (Standard) Setup:	7
Options:	7
Delete:	8
Manual Cylinder Bore:	8
Set Zero Tab:	8
Actual Position:	8
Velocity Override:	8
Zero Buttons:	8
Handwheel Buttons:	9
Spindle Start:	9
CW and CCW Creep:	9
Jog Buttons:	9
Move to:	9
Move To Zeros:	9
CW and CCW Index:	9
Operation:	10
Bottom of Bore:	10

Control Definitions:

The purpose of this chapter is to define the function of the buttons throughout the various screens. Certain button functions may not make sense right away in this chapter. As the operator reads through the Operating Instructions chapter of this manual, the function of these buttons will become clear.

Computer and Controller System Safety:

The computer and controller are located in the main rear electrical enclosure. This unit is a full computer, running Windows 7 64 Bit operating system. Contact the factory if more information on the computer system is required.

IMPORTANT: The computer in this machine has the ability to connect to the World Wide Web via Ethernet or Wireless using a USB wireless adapter. This machine should NOT be connected to the internet for any reason other than getting a software update. This should ONLY be done when directed to do so by a Rottler service technician. Updating Rottler Software when not directed by Rottler personnel will result in a non-operational machine.

Any "IT" personnel should ALWAYS get approval from Rottler before doing ANYTHING on the computer.



This machine is capable of causing severe injury or death. Doing any of the following without Rottler's direct consent may cause severe injury or death.



Connecting to the internet for any other reason will leave the machine vulnerable to viruses which could create a safety hazard and/or leave the machine inoperable.

Downloading ANY program from the Internet or by other means when not directed by Rottler is prohibited and will result in the machine warranty being NULL and VOID.



Downloading any program or changing any Rottler or Computer settings may cause the machine and/or software to become unstable. DO NOT install ANY screen saver, Anti-Virus, Spyware or any type of Security software on the computer. This could create a hazardous environment for the operator and personnel around the machine. Performing any of the above will also result in the machine warranty being NULL and VOID.



DO NOT connect any type of external hardware to the computer via USB or any other means. Do not install any type of Device Driver. This could create a hazardous environment for the operator and personnel around the machine. Performing any of the above will also result in the machine warranty being NULL and VOID.

Master Power On/Off Switch:

This switch is located on the main electrical control enclosure on the right hand side of the machine. The switch must be in the off position before opening the rear enclosure door.

When first applying power to the machine the computer will need to boot up. Be patient, it will take several minutes to complete booting. The Rottler program will not automatically start. Double tap the Rottler_WPF icon on the screen to start Rottler.

When turning the main power to the machine off there is a specific procedure to follow so as not to damage the computer. The computer must shut down its internal systems before main power is removed from it.

Press the "Start" button in the left-hand side of the Start Bar. This will bring up the "Start Menu". Press the "Shutdown" line at the bottom of the Start Menu. This will bring up a Pop Up menu, make sure that "shut down computer" is selected and press "OK".

This will shut down the computer. It is now OK to turn Main Power off to the machine.

Initialization Screen:

When the F90M is powered up the Rottler program will not automatically start. It may take several minutes for the computer to power. Start the Rottler program by double tapping the Rottler_WPF icon on the desktop. Once the program is started, the Rottler Program Select will appear.

NOTE: Do not push any buttons or icons on the screen before the Rottler program starts or an error may be caused on the computer.

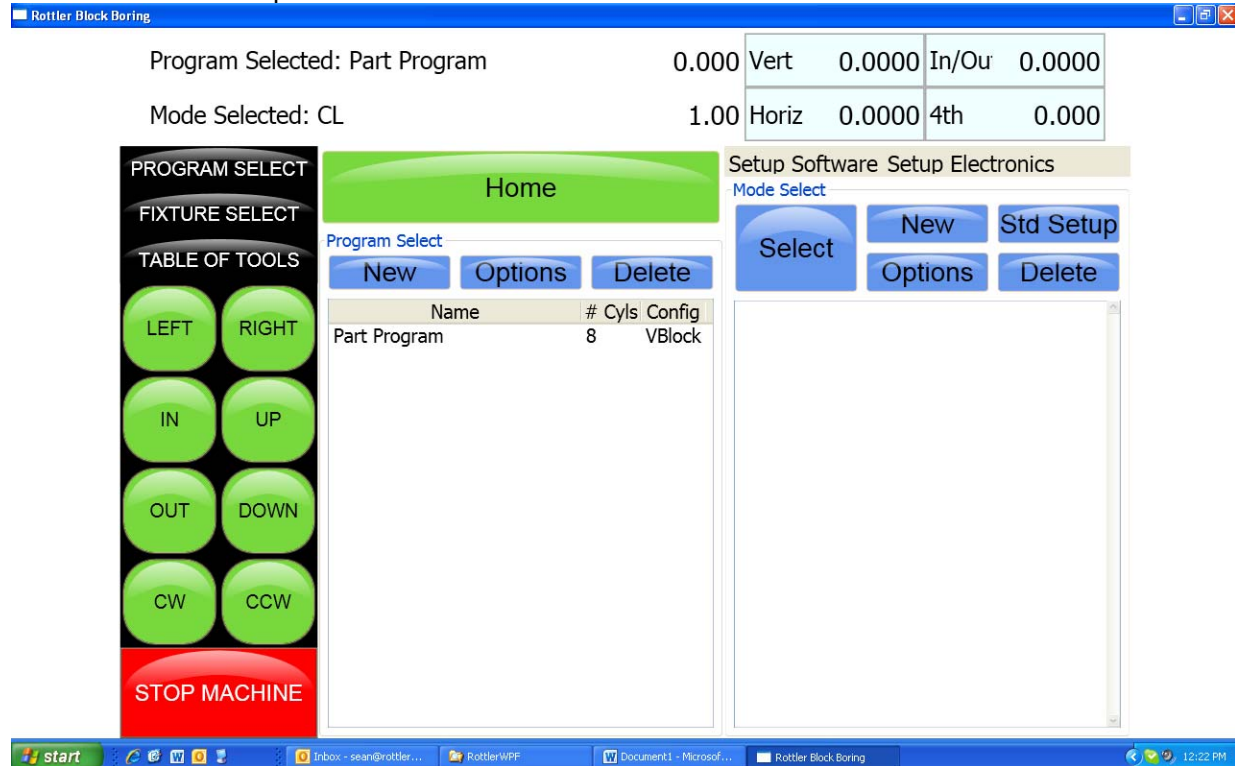

General Information:

The Rottler software operates on a Block Model format. You select or create the block you are working with. Then select or create an operation to be performed on that block.

Home:

Pressing this button will cause the machine to move all axis to their home (Machine Origin) position. The vertical will home first to be sure it is clear to move the other axis. The machine **MUST** be homed after it is turned on. This is how the machine gets its reference points to operate.

Program Select:

This is the left section of the screen. This is where you create and select blocks you will be working with.

New:

Pressing this in the Upper level will cause a dialog box to appear. Here is where you name and configure the block i.e number of cylinders and Inline or V Block.

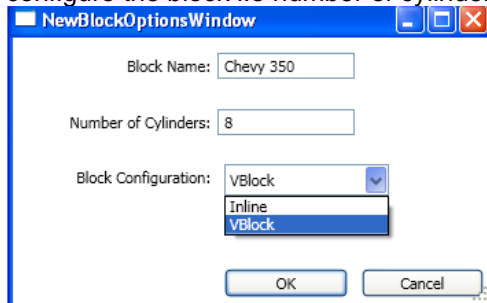

Pressing OK will result in the Block Model being inserted into the left hand side of the screen.

**Options:**

This will bring up the same dialog box as described above if any of the information needs to be changed.

Delete:

This will delete whatever block program is selected. A dialog box will appear to ask you if you want that program deleted.

Mode Select:

This is the right section of the screen. This is where you create or select operations to be performed on the selected Block. This area will be blank when you first create a block.

You can create only certain modes you will use on a block or use a standard set up that inserts all modes available. You can also create a new mode and rename it for a specific use.

New:

Pressing this button will bring up a dialog box with Rottler standard operations.

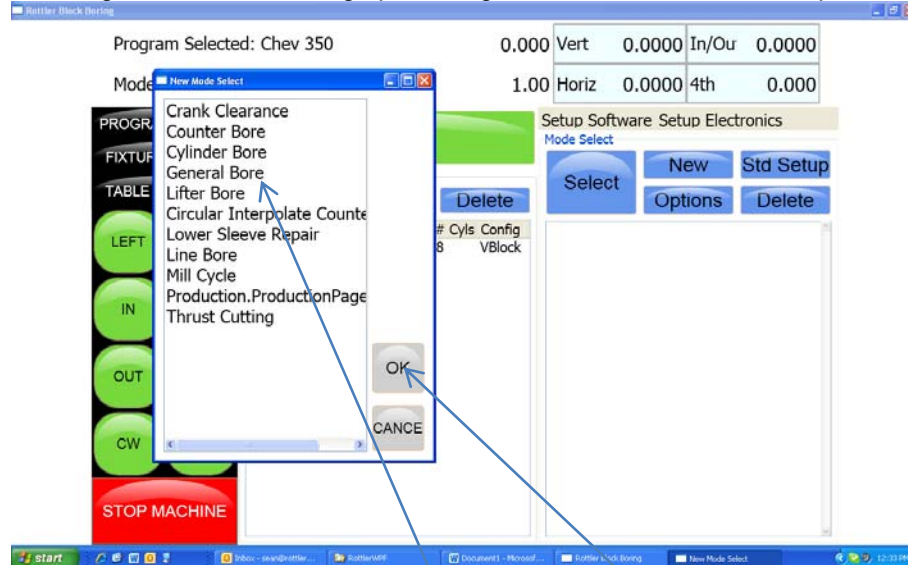

Select the operation you want to create and then press OK. This will place a general Bore operation under the Cylinder bore mode in the right hand section.



To enter General Bore mode highlight it and then press Select. This will take you to the operation screens that will be described later.

Std (Standard) Setup:

Pressing this button will insert all the Rottler operations into the right hand section automatically.

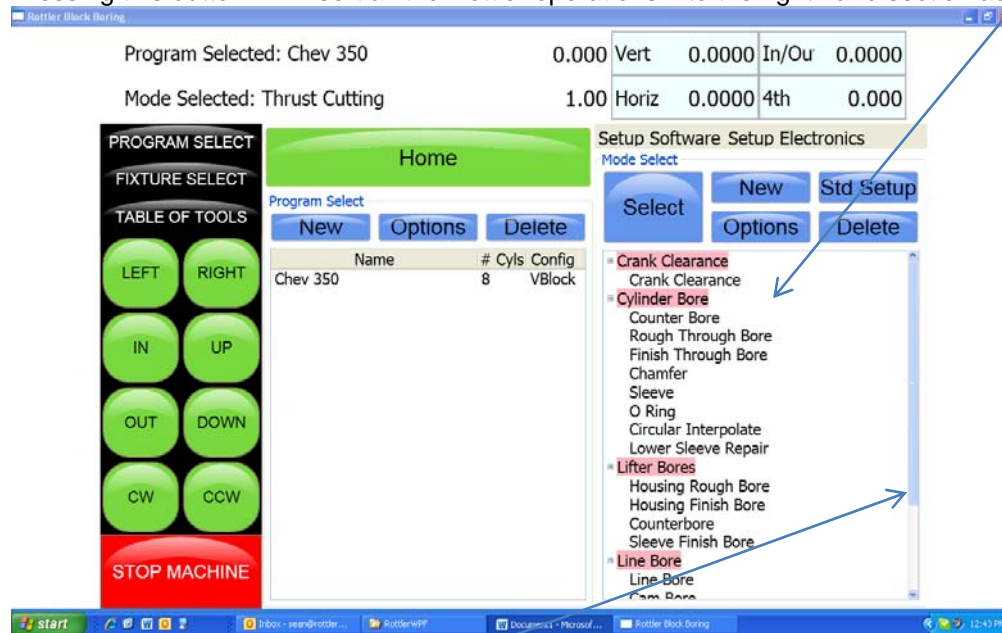

Use the slide bar on the right hand side to scroll through all the operations.

Options:

Press this button to bring up a dialog box to allow positive numbers to be entered in the horizontal stops. Most all programs are from left to right, the farther right you go the larger the negative number. However if a different zero point is used a positive number may be needed. For example, if you zero on the first cylinder on the left bank of a block and then "roll it over" the first cylinder is farther to the right than the zero position. Which would be a positive number.

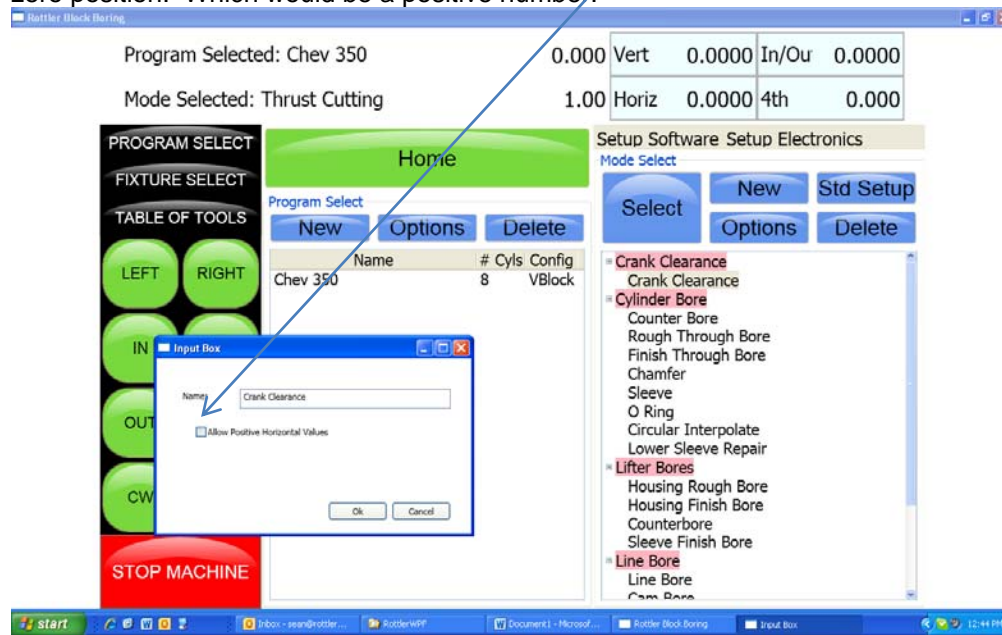

Delete:

This will delete the selected Mode. It will ask you if you want this mode deleted before deleting it.

NOTE: Once the control definition for a particular button has been discussed it will not be repeated in the different modes of operation. Only new buttons or buttons with a different function will be discussed in different modes.

For these descriptions the Tool# and Probe # are not being used. They will be described later in this chapter.

Manual Cylinder Bore:

Each buttons function will be described in this section. In the different MODES, the same buttons will not be described again.

Set Zero Tab:

Program Selected: Part Program	0.000	Vert	0.0000	In/Out	0.0000
Mode Selected: Manual Cylinder Bore	1.00	Horiz	0.0000	4th	0.000

Actual Position:

These are a numerical display showing the actual distance the axis are away from where they have been zeroed.

Velocity Override:

The Velocity override is displayed in the upper left of the Actual Position display. The default is 100% of the programmed Feed Rate. When operating... turning the handwheel Counter Clockwise will override the axis rapid travel and feed rate 100 and 0% when in an automatic cycle.

Zero Buttons:

These buttons will erase the actual position display of their associated axis and reset the displayed value to zero.

Handwheel Buttons:

These buttons will activate their associated axis for use with the handwheel. The left button of each axis will move the machine in .010" per detent, the middle button .010" per detent and the right .0001" per detent of the handwheel. Pressing any of the axis Jog buttons will disengage the handwheel.

Spindle Start:

This button will start the spindle at the RPM that is specified on the Auto Bore Cycle tab. Once the button has been pressed and the spindle is running the button will turn red and read Spindle Stop. Pressing the button again will stop the spindle and cause the button to go back to green.

CW and CCW Creep:

These buttons will cause the spindle to rotate slowly CW or CCW direction. The spindle will continue to rotate as long as the button is pressed. The speed at which the spindle will rotate is set in the Machine Parameters and should not be changed unless instructed to do so by the factory.

Jog Buttons:

These buttons control the rapid travel of the Vertical, Horizontal and In/Out axis. Pressing these buttons will allow you to move the machine through all ranges of its travel unobstructed. If the spindle is turned on these buttons become feed buttons and the machine will feed in whatever direction you have pressed. The rate at which the machine will feed is determined by the value set in the Auto Bore Cycle tab. When in rapid travel, these buttons are momentary contact and you will have to keep them pressed to keep the machine moving. When the spindle is on, they are latching buttons and once they are pressed the travel will continue until they are pressed again.

Move to:

Pressing these buttons will bring up a dialog box for the associated axis. Enter a value that you want the axis to move to and press ENTER. That axis will then move to that position. You can do multiple "Move To" at the same time. One after another.

Move To Zeros:

Pressing this button will cause the vertical to move the zero position first. The in/out and horizontal will move after the vertical has moved to zeros.

CW and CCW Index:

Pressing either of these buttons will cause the spindle to rotate to the index position. Index position is with the tool to the right as you are facing the machine.

Important:**Setting Spindle Index:**

Any time the machine has been turned off the spindle index position must be set. Turn the spindle to the index position (tool holder facing to the right at 90 degrees from the operator). Then press the Zero button net to the spindle position read out. This will put a zero value in the display box.

This screen also shows the Spindle Load, programmed Feed Rate and Spindle RPM.

Operation:

This screen is used to set the Vertical stop and final RPM the machine will use to bore a cylinder.

Program Selected: Part Program	0.000	Vert	0.0000	In/Out	0.0000
Mode Selected: Manual Cylinder Bore	1.00	Horiz	0.0000	4th	0.000

The screenshot shows a control panel with a 'PROGRAM SELECT' section containing buttons for LEFT, RIGHT, IN, UP, OUT, DOWN, CW, and CCW, and a red 'STOP MACHINE' button. The main display area has two tabs: 'Set Zeros' and 'Operation'. The 'Operation' tab is selected and shows two main sections: 'DEPTHS' and 'DWELL OPTIONS'. In the 'DEPTHS' section, 'Bottom of Bore' is set to 0.0000 with a 'SET' button. Below it is a checkbox for 'Stop and Index Spindle After Cycle'. The 'DWELL OPTIONS' section has 'Finish RPMS' set to 60.00 and 'Finish Revolutions' set to 2.00. A large green 'START AUTO CYCLE' button is at the bottom right.

Bottom of Bore:

Set this stop to the length of the bore. This will be a negative number. The boring cycle will start at Vertical 00.000.

Chapter 3 Contents

Operating Instructions:	3
Loading Blocks:.....	3
Small Gas and Diesel:	3
Manual V6/V8 Combination Fixture:	3
Normal Operating Procedure:	6
Normal Operating Procedure:	10
Retrofitting 502-1-15C Parallels to V6/V8 Combination Fixture.....	11
Diesel Blocks:.....	13
6725 Diesel Fixture:	13
Small Diesel V Blocks:	13
Triangle Clamping:	14
Block Clamp Arm:.....	15
Small Diesel In Line Blocks:.....	17
Triangle Clamping:	18
6405F Large V-Block Fixture	20
Triangle Clamping:	21
6821 Adjustable, Universal Line Bore Parallel Assembly:	30
7119V Dual Axis Table Assembly:.....	35
Instructions for Small In-Line Blocks:	36
Mounting Block to Table:.....	36
Blocks with Main Caps Removed or Raised Main Bearings:.....	36
Blocks with Main Caps Installed:.....	37
Typical Head Set Up Procedure:.....	38
12" Multi Tooth Milling Head - 6865.....	41
18" Multi Tooth Milling Head 6864	41
General Machine Information:.....	42
Homing:	42
Building Programs:.....	43
Create a Block Program:.....	43
New:	43
Options:	43
Creating Operating Modes for a Block Model:.....	43
New:	43
Std (Standard) Setup:.....	45
Select:.....	45
Options:	45
Manual Cylinder Bore:	46

Operation:	47
Bottom of the Bore:	47
Stop and Index Spindle after Cycle:	47
Finish RPMS and Revolutions:.....	47
Start Auto Cycle:	47
Manual Lower Sleeve Repair:.....	48
Start Boring Height:	48
Horz Clearance:	48
Horiz Overshoot:	48
Bottom of Bore:	48
Start Auto Cycle:	48
Manual Line Bore:.....	49
Bore Length:.....	49
Start Auto Cycle:	49
Manual Mill:	50
Horizontal End:.....	50
Start Auto Cycle:	50

Operating Instructions:

The purpose of this chapter is to explain and then guide the operator from loading a block through running an automatic cycle.

All modes of operation will be discussed in this chapter.

Note: *We recommend, particularly for operators unfamiliar with the boring machine, to practice on a junk block in order to become familiar with the controls and procedures of the boring machine.*

Loading Blocks: Small Gas and Diesel:

Manual V6/V8 Combination Fixture:

502-1-72H

WARNING

Handle the block and fixture with EXTREME care and guidance. A block hoist is REQUIRED. Mishandling of a heavy engine block and fixture may result in the dropping of parts and personal injury.

The Model 502-1-72H manual V6/V8 combination fixture is a fast, simple and universal system to properly and accurately hold most 60 degree V-type engine blocks for either cylinder boring or deck surfacing.

See illustration on the following page.

Boring Application:

NOTE: *The block must have the main bearing caps in place and torqued.*

Care must be taken to assure the contact edges of the locator bar are near the cap split line. A pair of 3/8" and 1/2" spacers are provided for blocks with large main bearing bores, to enable the bar to locate near the main bearing split line. (See figure 2)

V-blocks:

(blocks with main bearing center lines no more than 1/2" higher than the pan rail plane) are mounted with the 502-3-8B V-block frame in place. Select the 90-degree option placement of the frame to suit block length, or main bearing caps will interfere with frame. Rotate frame 90 degrees by moving its shoulder screws to alternate set of holes.

Y-Blocks:

(blocks with main bearing center lines 2-3/8" to 3-1/2" higher than the pan rail plane) are mounted directly on the fixture. Some Y-blocks (GM 60 degree) have too narrow pan rails and some have too low main bearing location which will require the use of the 502-1-15C precision 1-1/4" x 3" parallel set to raise and or support the block. Use the shoulder screw from the V-block frame and hook the parallels over the back of the V-fixture.

This fixture may be easily repositioned on the support parallels (without a block in place) to shift from the 60 degree support surface to the 90 degree support surface or vice versa.

REF2MB17-031993

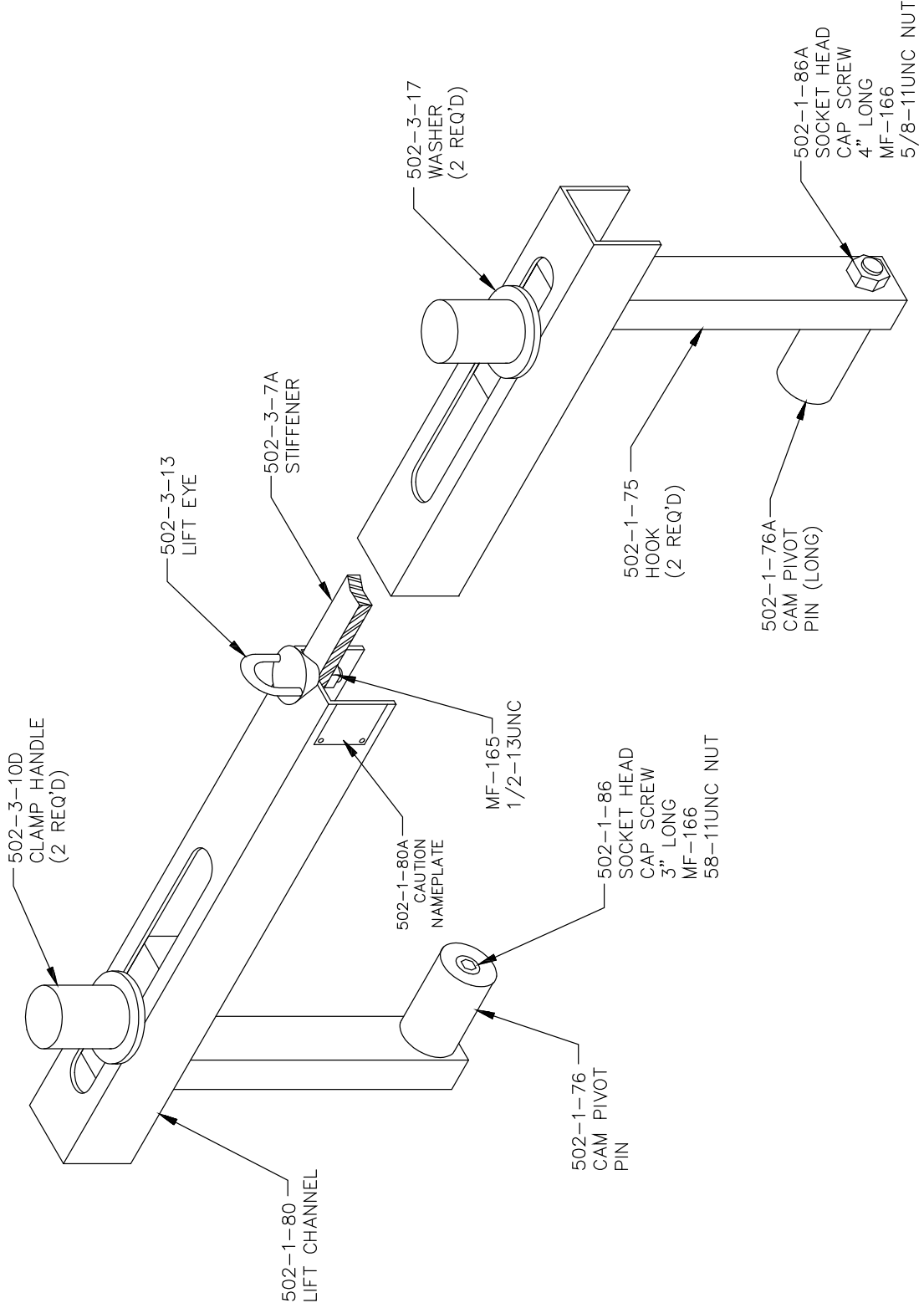

▲ WARNING

Extreme care must be taken by operator whenever handling large blocks. Large blocks may cause fixture to tip when floated too far outward. We recommend leaving hoist attached when moving these blocks. Large blocks should be lifted from the block bank surface. **DO NOT** use the 502-1-95 block handler assembly on these blocks.

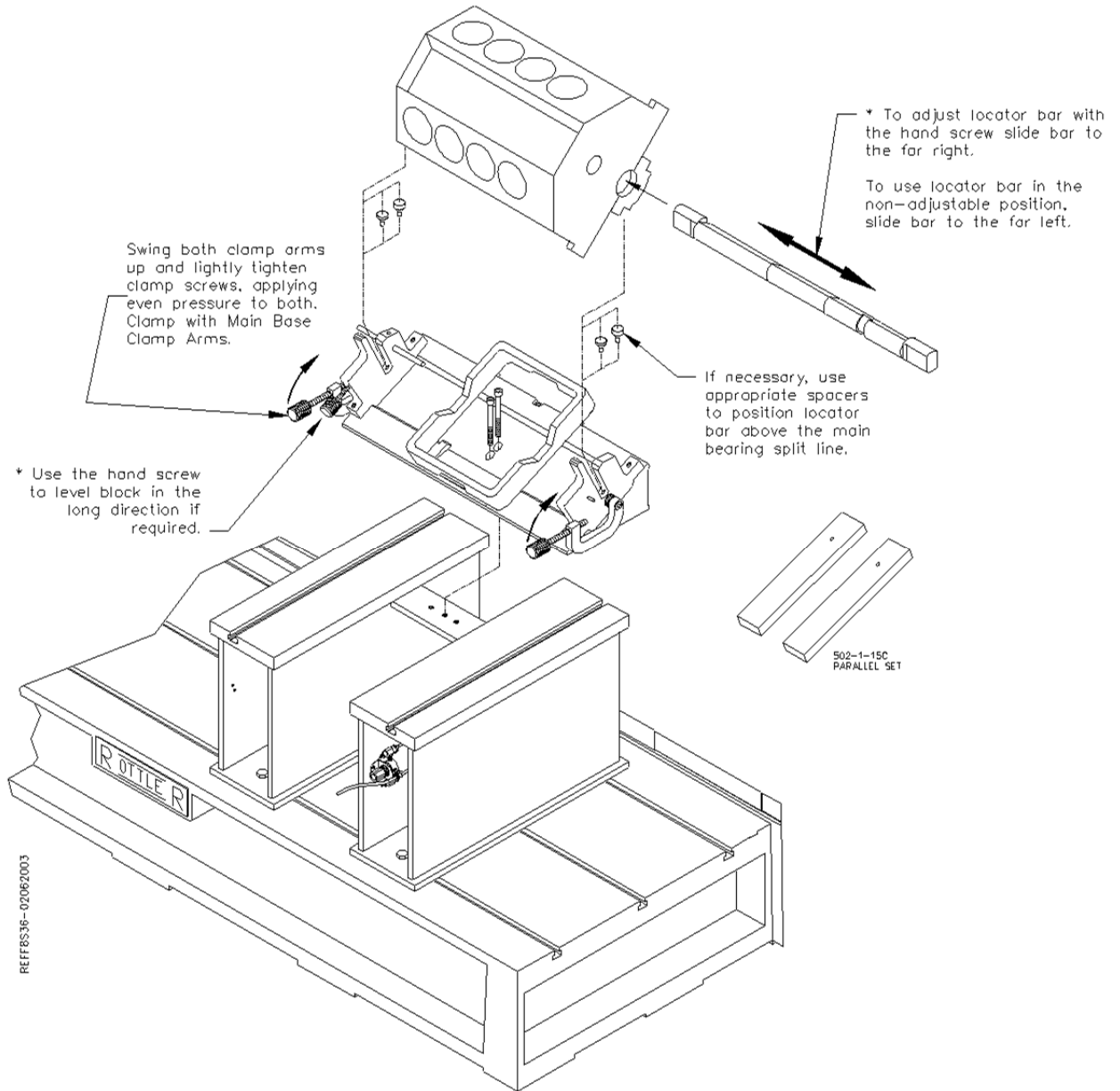

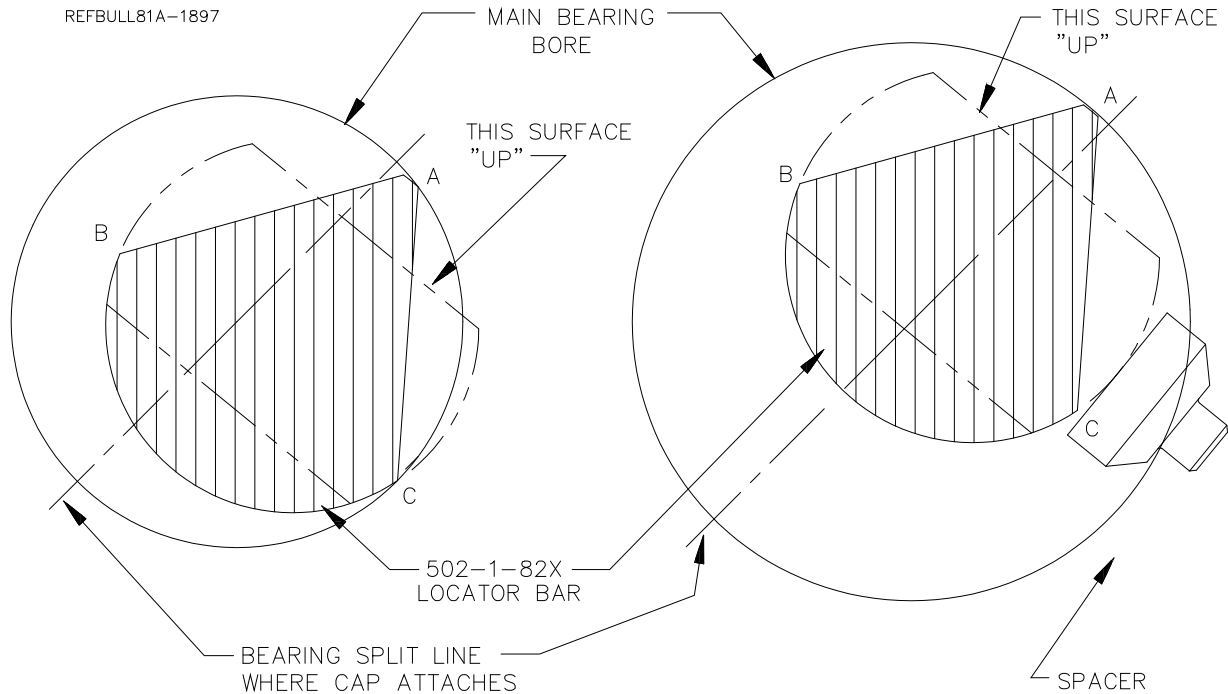

FIGURE 1

FIGURE 2

Normal Operating Procedure:

The normal operation procedure on smaller V-blocks is to first pick up the block. If using the optional 502-1-95 block handler attach it to the block making sure the cam lifters are COMPLETELY engaged, and that the lift hook is approximately centered in the block lengthwise. Place the 502-1-82X locator bar through the main bearings and hoist the block into the fixture. Pulling the block towards you, with the locator against the positioners, will prevent jamming in the slot of the guides during the loading and unloading operations. The locator bar is positioned with the word 'UP' that is on the end of the bar facing up and away from the operator. (see figure 1) After the locator bar is engaged in the positioners, pivot block outwards as you lower it. Slide block to the far left (this is the non adjustable position).

Make sure the block is firmly seated in place and not resting on pan-rail burrs or other interference points. Accurate seating can also be a problem with extremely warped, distorted blocks. Another cause of problems is failure to remove main bearing inserts. The locator bar has a relief for blocks with a small main bearing or seal. Rotate locator bar clamps into position & lightly tighten the hand screws, applying even pressure to both. Clamp the block securely with the main base clamp arms.

Warped or distorted blocks may require leveling of the deck surface in the long direction. This is possible with the hand-screw assembly in the left-hand bar positioner. Loosen both clamp hand-screws and slide the locator bar to the far right position. Retighten both clamp hand-screws. Raise or lower the adjusting hand-screw as required. For the non-adjustable position slide locator bar to the far left.

Push fixture back into bore position. There is a guide block (502-1-105) attached to the bottom of the fixture to aid in guiding the fixture along the support ways.

Operate the block clamp arms, bore, and pull fixture back to the load position.

Loosen locator bar hand screws and rotate clamps out of the way. Lift the block, either from the deck surface or with the optional 502-1-95 block handler. Turn the block 180 degrees & reload to duplicate the operation on the other bank.

After turning the engine block 180 degrees the locator bar must be twisted 180 degrees also. Again the word 'UP' must enter into the positioners facing up and away from the operator. (See figure 1).

Figure 1

502-1-82X main bearing locator bar indexes at point A. When bank is reversed and the bar is twisted 180 degrees, point A still indexes the main bearing.

Point C holds the block down. When bank is reversed and the bar is twisted 180 degrees, point B holds the block down.

Figure 2

502-1-82X main bearing locator bar indexes near bearing split line. Point C does not contact the bearing cap but rests on matched spacers that are provided to fit in the bar positioners slot. If there is a means of holding the block down such as block clamp towers, this method may be used in large bores in order to properly index near the bearing split line. If extreme care is used this method may be used to index blocks without bearing caps attached. (Optional clamp down must be provided).

Surfacing Application:

NOTE: The block must have the main bearing caps in place and torqued.

Care must be taken to assure the contact edges of the locator bar are near the cap split line. A pair of 3/8" and 1/2" spacers are provided for blocks with large main bearing bores, to enable the bar to locate near the main bearing split line. (See figure 2)

V-blocks:

(blocks with main bearing center lines no more than 1/2" higher than the pan rail plane) are mounted with the 502-3-8B V-block frame in place. Select the 90-degree option placement of the frame to suit block length, or main bearing caps will interfere with frame. Rotate frame 90 degrees by moving its shoulder screws to alternate set of holes.

Y-Blocks:

(blocks with main bearing center lines 2-3/8" to 3-1/2" higher than the pan rail plane) are mounted directly on the fixture. Some Y-blocks (GM 60 degree) have too narrow pan rails and some have too low main bearing location which will require the use of the 502-1-15C precision 1-1/4" x 3" parallel set to raise and or support the block. Use the shoulder screw from the V-block frame and hook the parallels over the back of the V-fixture.

This fixture may be easily repositioned on the support parallels (without a block in place) to shift from the 60 degree support surface to the 90 degree support surface or vice versa.

▲ WARNING

Extreme care must be taken by operator whenever handling large blocks. Large blocks may cause fixture to tip when floated too far outward. We recommend leaving hoist attached when moving these blocks. Large blocks should be lifted from the block bank surface. **DO NOT** use the 502-1-95 block handler assembly on these blocks.

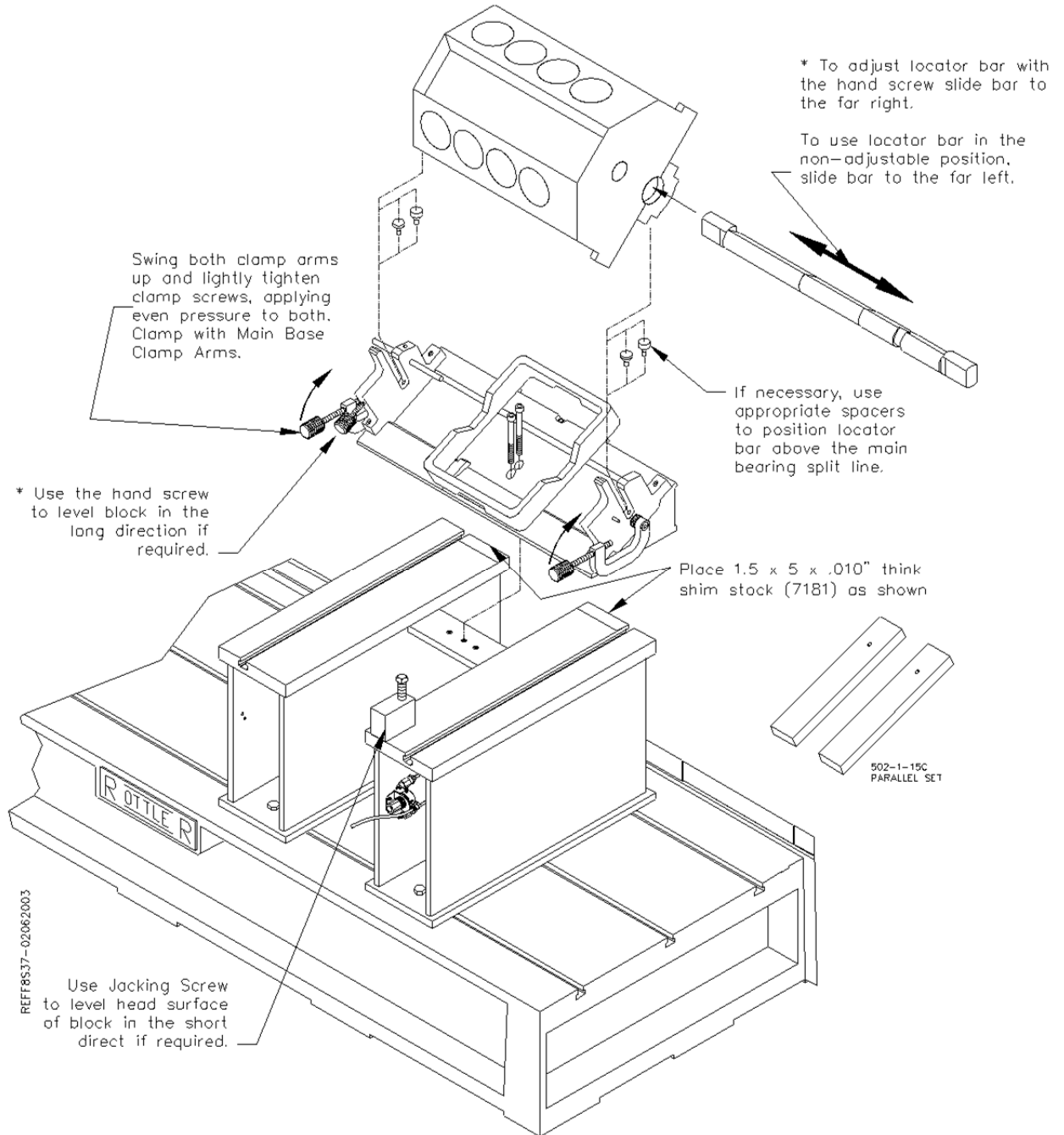

Normal Operating Procedure:

The normal operation procedure on smaller V-blocks is to first pick up the block. If using the optional 502-1-95 block handler (see page 9.20), attach it to the block making sure the cam lifters are COMPLETELY engaged, and that the lift hook is approximately centered in the block lengthwise. Place the 502-1-82X locator bar through the main bearings and hoist the block into the fixture. Pulling the block towards you, with the locator against the positioners, will prevent jamming in the slot of the guides during the loading and unloading operations. The locator bar is positioned with the word 'UP' that is on the end of the bar facing up and away from the operator. (see figure 1) After the locator bar is engaged in the positioners, pivot block outwards as you lower it. Slide block to the far left (this is the non adjustable position).

Make sure the block is firmly seated in place and not resting on pan-rail burrs or other interference points. Accurate seating can also be a problem with extremely warped, distorted blocks. Another cause of problems is failure to remove main bearing inserts. The locator bar has a relief for blocks with a small main bearing or seal. Rotate locator bar clamps into position & lightly tighten the hand screws, applying even pressure to both. Clamp the block securely with the main base clamp arms.

Warped or distorted blocks may require leveling of the deck surface in the long direction. This is possible with the hand-screw assembly in the left-hand bar positioner. Loosen both clamp hand-screws and slide the locator bar to the far right position. Retighten both clamp hand-screws. Raise or lower the adjusting hand-screw as required. For the non-adjustable position slide locator bar to the far left.

Push fixture back into surfacing position with the back of the fixture on the Shim Stock. The shim stock is put in place to raise the back side of the block, you can then use the Jacking Screw to raise and lower the front of the block. There is a guide block (502-1-105) attached to the bottom of the fixture to aid in guiding the fixture along the support ways.

Operate the block clamp arms, surface, and pull fixture back to the load position.

Loosen locator bar hand screws and rotate clamps out of the way. Lift the block, either from the deck surface or with the optional 502-1-95 block. Turn the block 180 degrees & reload to duplicate the operation on the other bank.

After turning the engine block 180 degrees the locator bar must be twisted 180 degrees also. Again the word 'UP' must enter into the positioners facing up and away from the operator. (See figure 1).

Figure 1

502-1-82X main bearing locator bar indexes at point A. When bank is reversed and the bar is twisted 180 degrees, point A still indexes the main bearing.

Point C holds the block down. When bank is reversed and the bar is twisted 180 degrees, point B holds the block down.

Figure 2

502-1-82X main bearing locator bar indexes near bearing split line. Point C does not contact the bearing cap but rests on matched spacers that are provided to fit in the bar positioners slot. If there is a means of holding the block down such as block clamp towers, this method may be used in large bores in order to properly index near the bearing split line. If extreme care is used this method may be used to index blocks without bearing caps attached. (Optional clamp down must be provided).

Retrofitting 502-1-15C Parallels to V6/V8 Combination Fixture (Special Applications)

Some engine blocks with large main bores (3-1/8" and larger) cause a problem of the locator bar bottoming out in the bar positioners and/or the V-shaped relief's of the 502-3-8B V-block frame before clamping the block properly. Mounting the 502-1-15C parallel set as shown below in place of the V-block frame will provide proper clearance for clamping. Older style fixtures and parallels can be modified to this configuration using illustrations below.

V-6 blocks with one-piece 'caged' main bearing caps (all caps are connected) can interfere with 502-3-8B V-block frame. The parallel arrangement shown below will allow proper support and clamping of these blocks.

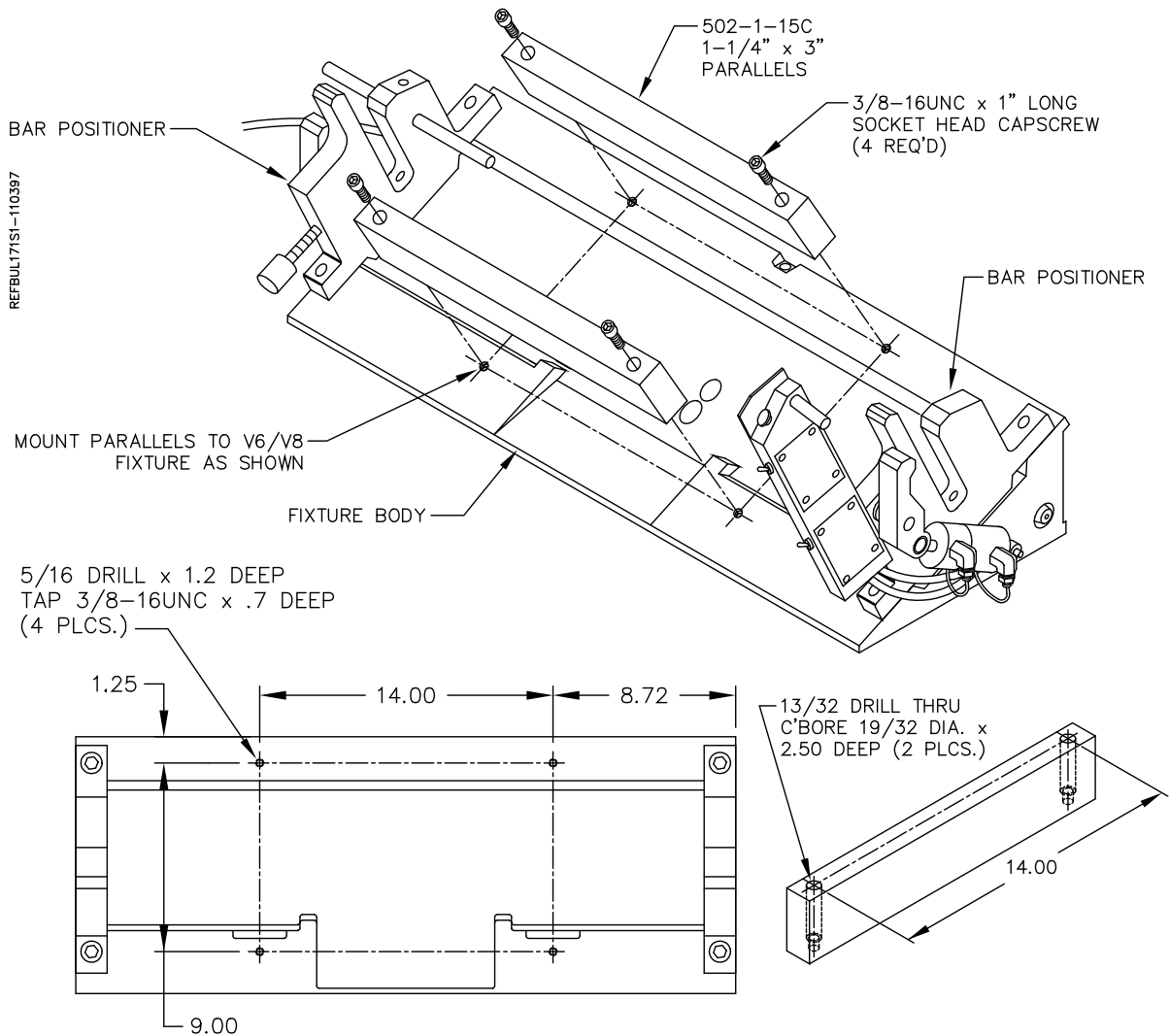

Some V-6 engine blocks (for example Buick V-6) have main bearing bores that are too low in respect to the pan rails. This presents a problem of the locator bar bottoming out in the bar positioners before the block is properly clamped. Positioning the 502-1-15C parallel set as shown below will raise the block enough to provide proper clamping.

REFBUL171S2-110397

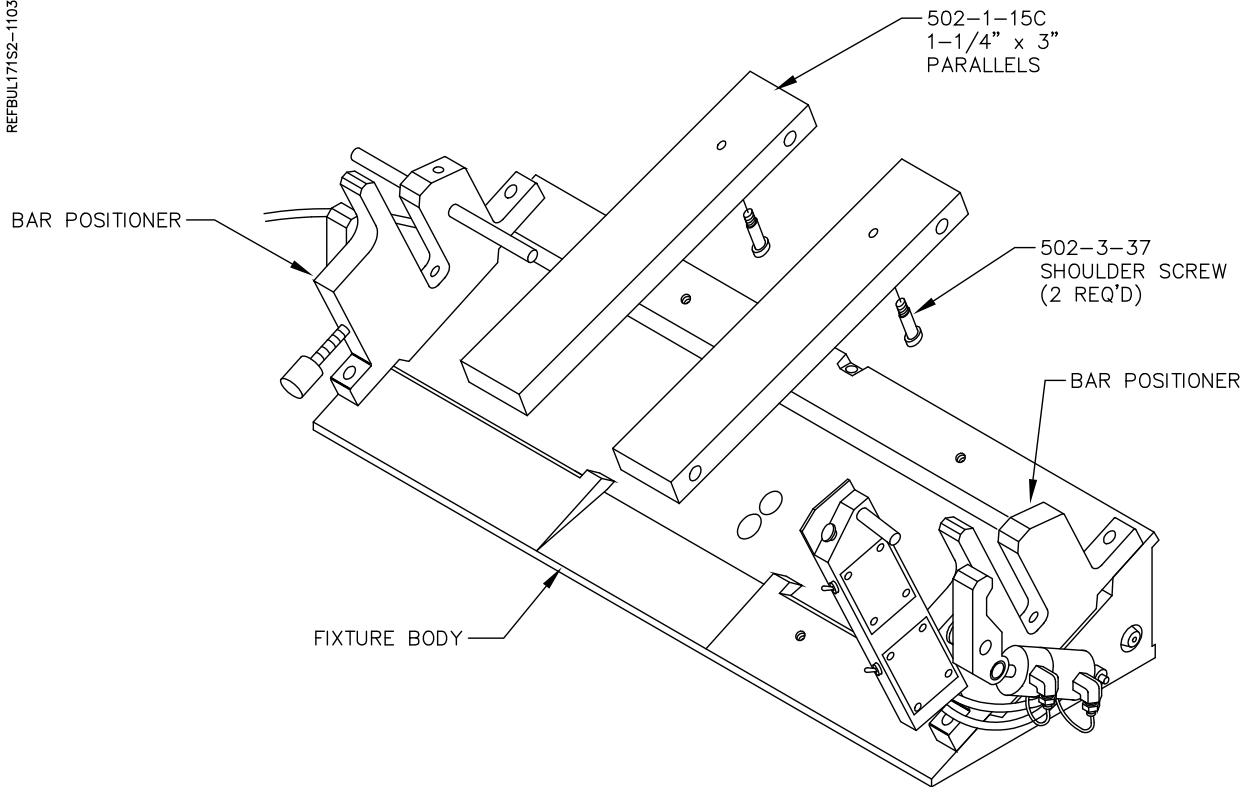

Diesel Blocks: 6725 Diesel Fixture:

Small Diesel V Blocks:

On these blocks it will be necessary to install the 6370Z, 10" parallels or 6794E, 8" parallels onto the bed of the machine. These parallels are keyed, place them onto the deck surface and then push them toward the rear of the machine. This will locate them evenly on the middle keyway of the machine bed. Place the two 6553F main bearing supports onto the parallels, these are also keyed and fit into the machined slots on the parallels. This will put the two main bearing supports in line with each other. Tighten all bolts to lock the parallels and main bearing support into place. Select the correct size main bearing locators and install them into the mains of the block..

Note: *Make sure there are no burrs or debris in the main bearing bores where they will contact the main bearing locators. This can cause the block not to clamp properly and may cause tipping or rocking of the block.*

WARNING

Handle these large blocks with Extreme care and guidance. A block hoist is required when handling these blocks. These blocks should be lifted from the block bank surface. DO NOT use 502-1-95 Block Handler assembly on these blocks.

Install the main bearing locators into the mains of the engine block. Lower the block so that the locators go into the main bearing support.

DANGER

The hoist must remain attached to the block until it is firmly clamped into position. The blocks will have a tendency to tip forward until they are properly supported and clamp. When not properly supported and attached to a hoist these blocks will roll forward and out of the fixture. This will cause severe injury or death to operator.

Select the correct jacking screw to reach the block. Place the jacking screws into the jack bodies and place on the parallels in a location they will support the block from rolling forward.

Position the block clamps so the front of the shoe will clamp the block in the middle on both ends. The following illustration shows the correct triangle clamping system that should be used.

You can raise and lower the ends of the block by rotating the Hex nut located on the ends of the main bearing locators.

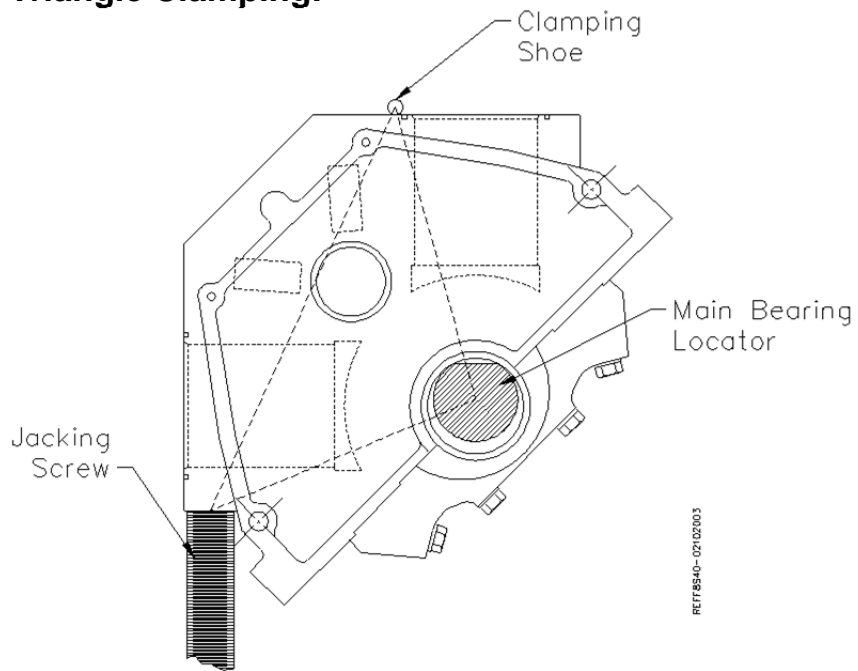
Triangle Clamping:

Adjust the height so the shoes rest on the clamp points. Tighten the clamp leg handles. Actuate the clamp shoes by turning their knobs. Apply pressure to the two clamps as evenly as possible to avoid tipping the block up on one side.

Block Clamp Arm:

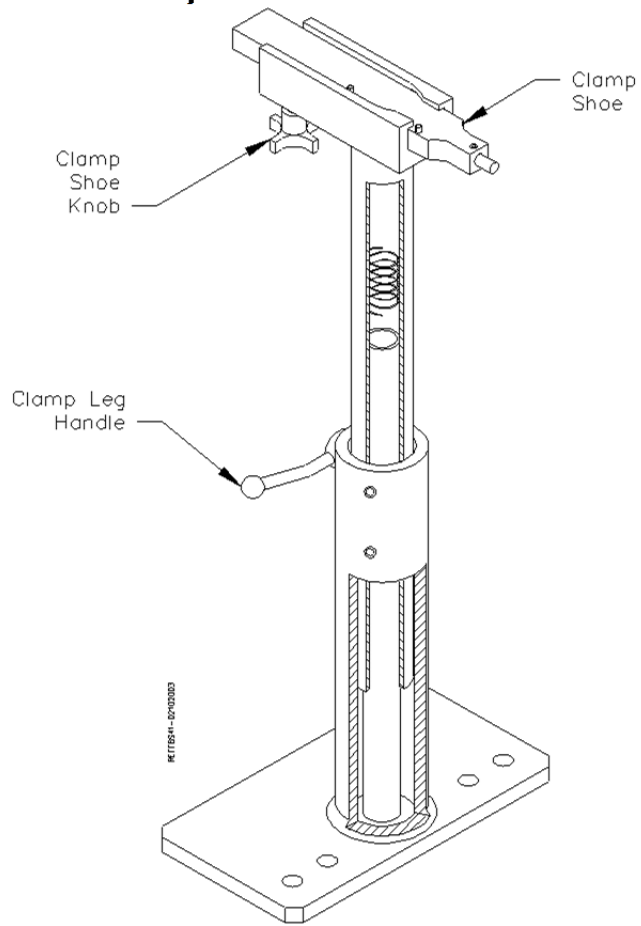

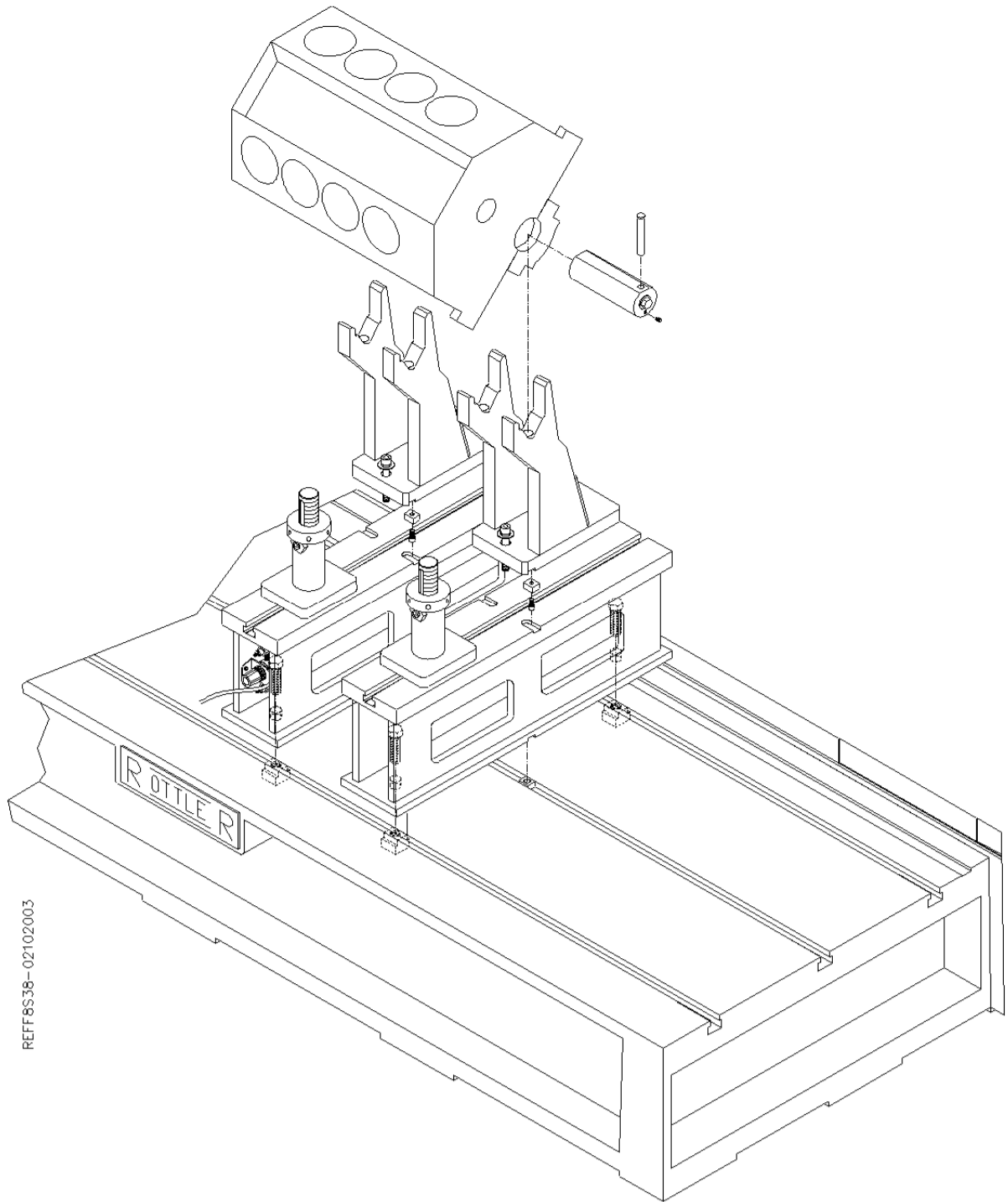

REF F8S38-02102003

Small Diesel In Line Blocks:

On these blocks it will be necessary to install the 6370Z, 10" parallels onto the bed of the machine. These parallels are keyed, place them onto the deck surface and then push them toward the rear of the machine. This will locate them evenly on the middle keyway of the machine bed. Place the two 6553F main bearing supports onto the parallels, these are also keyed and fit into the machined slots on the parallels. Use the forward machined slots. This will put the two main bearing supports in line with each other, and on centerline of the machine bed. Position the fixtures at a distance apart equal to the outboard main journals. Tighten all bolts to lock the parallels and main bearing support into place. Select the correct size main bearing locators, and install them into the mains of the block. Notice the locators have a flat area. Installing with the flat side up will allow end to end height adjustment of the block by rotating the locator. Installing with the round side up will position the block so all machining operations are parallel and perpendicular to the main bore centerline. This simply requires leveling the block in the front to rear direction.

Note: *Make sure there are no burrs or debris in the main bearing bores where they will contact the main bearing locators. This can cause the block not to clamp properly and may cause tipping or rocking of the block.*

WARNING

Handle these large blocks with Extreme care and guidance. A block hoist is required when handling these blocks. These blocks should be lifted from the block bank surface. DO NOT use 502-1-95 Block Handler assembly on these blocks.

Lower the block so that the locators go into the main bearing support. A clevis pin is provided to keep the locator in position on the main bearing support.

For in-line blocks, load the block with the heavier side towards the front.

DANGER

The hoist must remain attached to the block until it is firmly clamped into position. The blocks will have a tendency to tip until they are properly supported and clamp. When not properly supported and attached to a hoist these blocks will roll forward or backwards and out of the fixture. This will cause severe injury or death to operator.

Select the correct jacking screws to reach the block. Place the jacking screws into the jack bodies and place on the machine bed in a location they will support the block from rolling forwards. Rough level the block using a spirit level.

The following illustration shows the correct triangle clamping system that should be used.

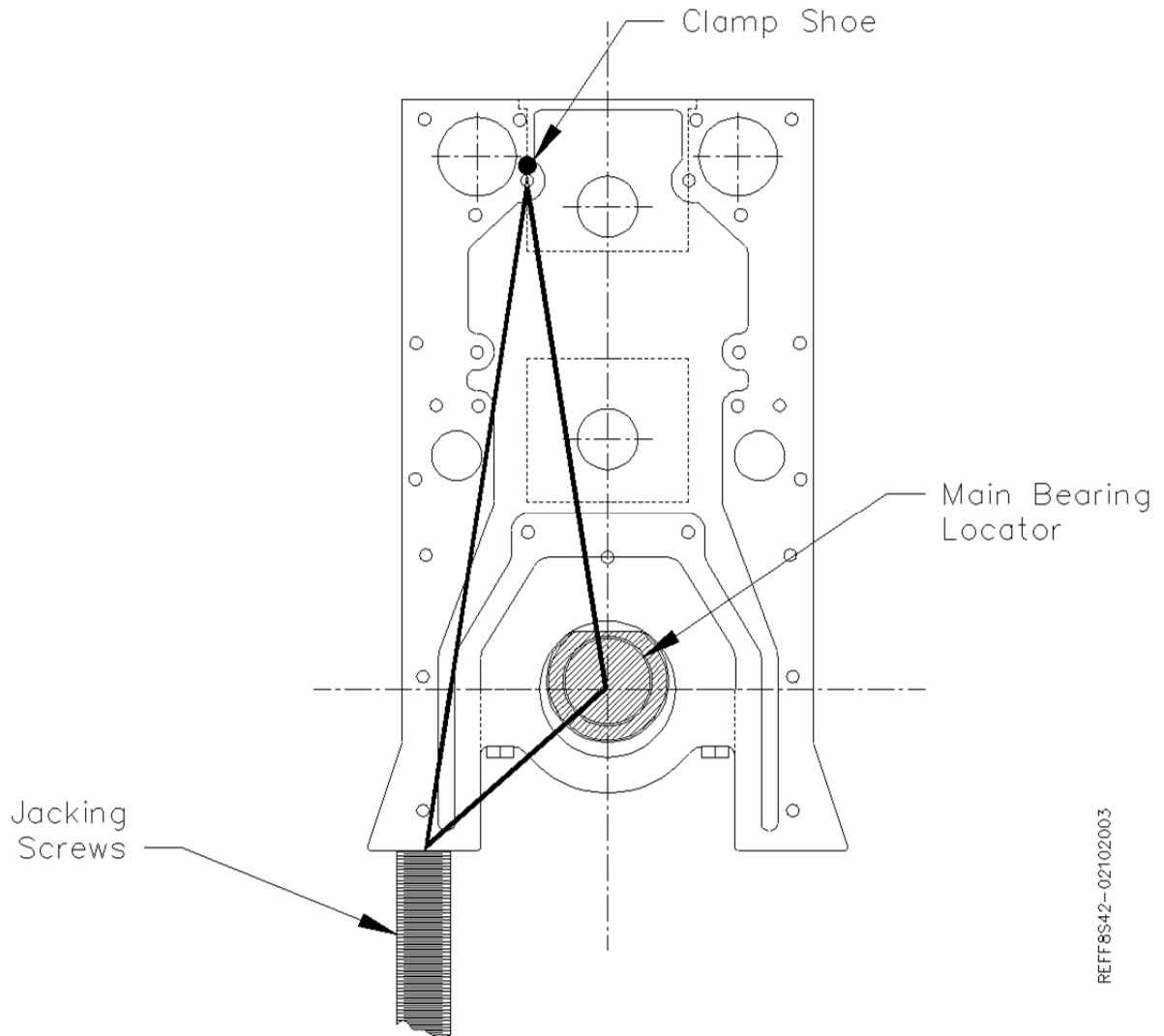
Triangle Clamping:

Adjust the height so the shoes rest on the clamp points. Tighten the clamp leg handles. Actuate the clamp shoes by turning their knobs. Apply pressure to the two clamps as evenly as possible to avoid tipping the block up on one side.

Be sure the clamp is below the deck surface if you to resurface the block.

▲ WARNING

Do not release the hoist or lifting device from the block until the clamping is secure.

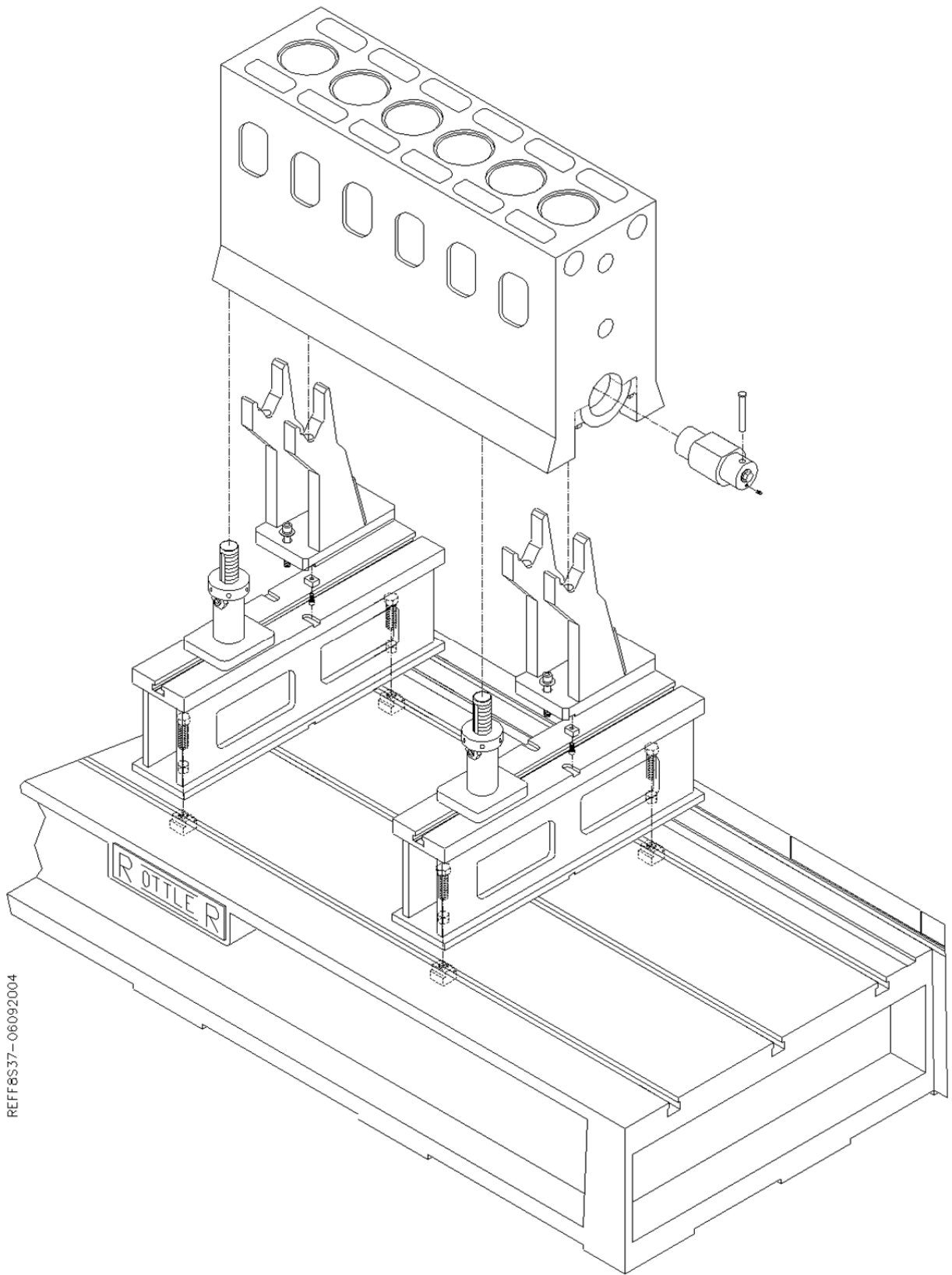

REF8S37-06092004

6405F Large V-Block Fixture

Place the 6405 supports on the machine bed. Make sure there is no debris or burrs on the mating surfaced. The supports should be placed on the machine bed with the two dowels on the bottom of the supports into the middle keyway. Place the supports the same distance apart as the mains you will be using. On long blocks, it is recommended to use main bearing locations inward from the ends, to more equally balance the block and avoid sag. Push the supports back toward the rear of the machine against the dowel pins. This will line the supports up with each other. Tighten the four (4) mounting bolts on each support.

Install the correct size locators into the main bores that will be used.

▲ WARNING

Handle these large blocks with Extreme care and guidance. A block hoist is required when handling these blocks. These blocks should be lifted from the block bank surface.

▲ DANGER

The hoist must remain attached to the block until it is firmly clamped into position. The blocks will have a tendency to tip until they are properly supported and clamp. When not properly supported and attached to a hoist these blocks will roll forward or backwards and out of the fixture. This will cause severe injury or death to operator.

The main bearing bores being used, should be on centerline of each support. Set the jacking bodies, with the proper length jack screw installed onto the machine base. These should be located in the general area of the supports. Temporarily secure to the deck with at least one bolt.

Lower the block down onto the supports. Place a level on the deck of the engine block and check the level front to back. Position the jack stands in a location to properly support the block and secure. To level, use the jacking screws to raise or lower the front of the engine block.

Position the block clamps on the machine bed and secure in a location to allow proper clamping.

The following illustration shows the correct triangle clamping system that should be used.

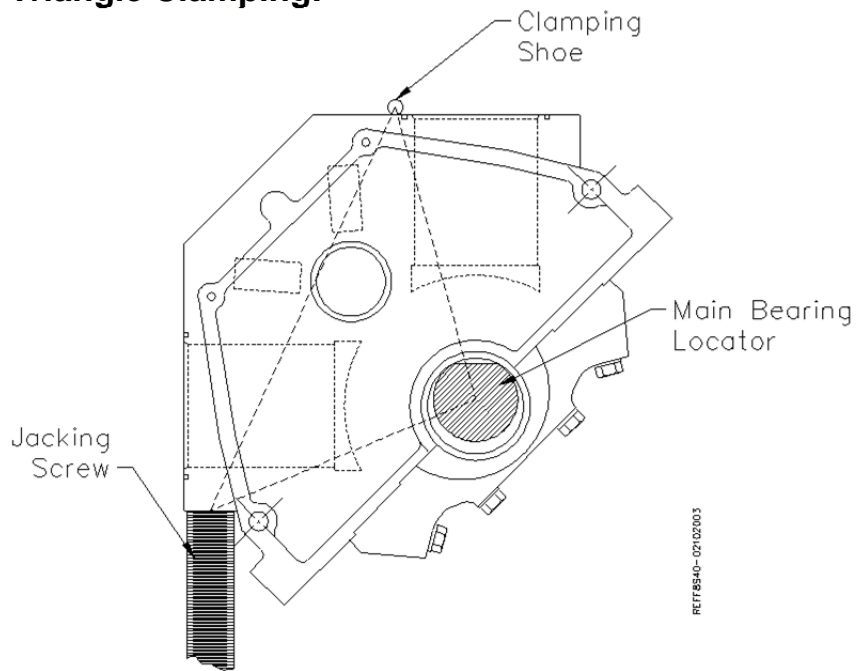
Triangle Clamping:

Adjust the height so the shoes rest on the clamp points. Tighten the clamp leg handles. Actuate the clamp shoes by turning their knobs. Apply pressure to the two clamps as evenly as possible to avoid tipping the block up on one side.

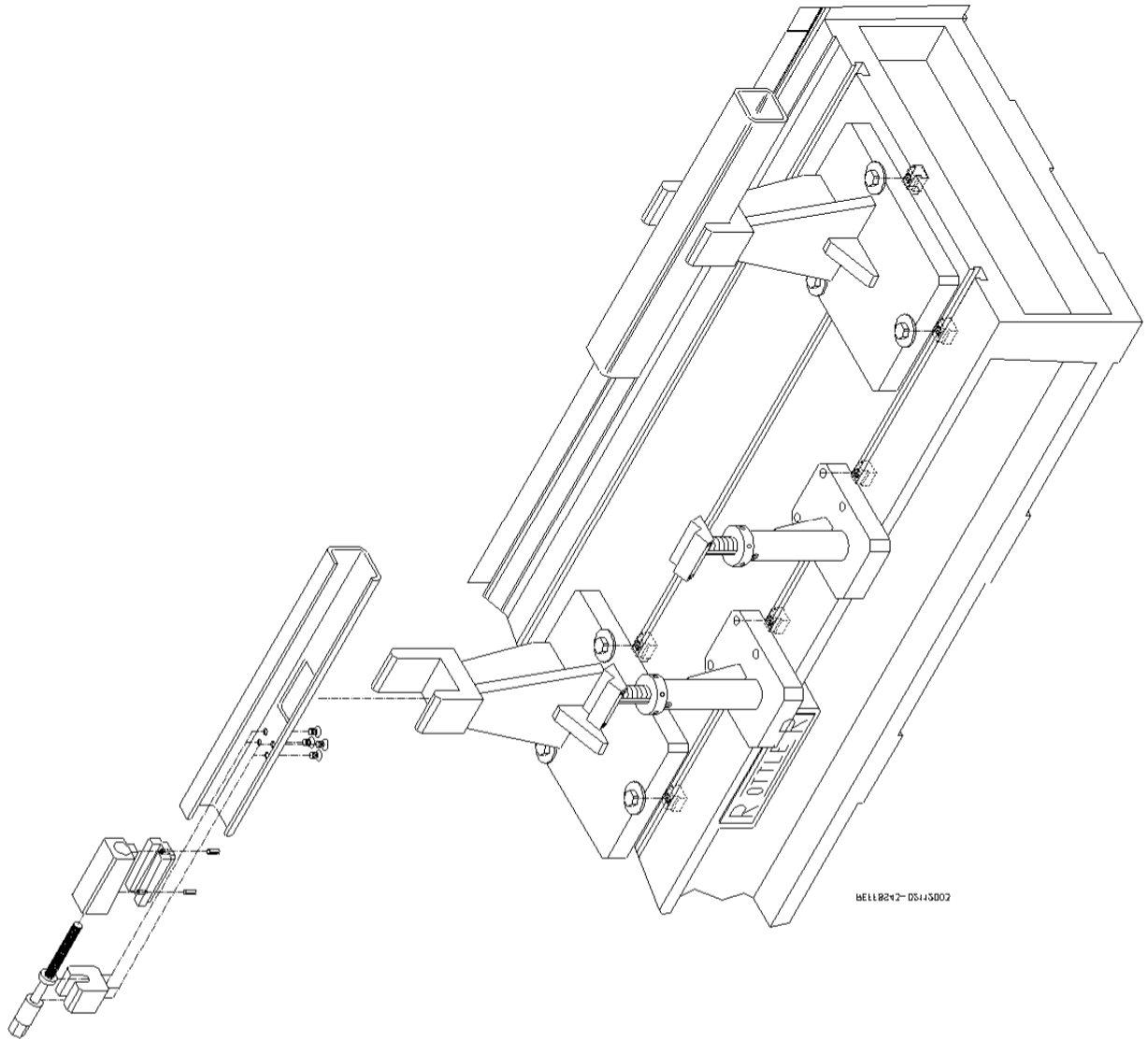

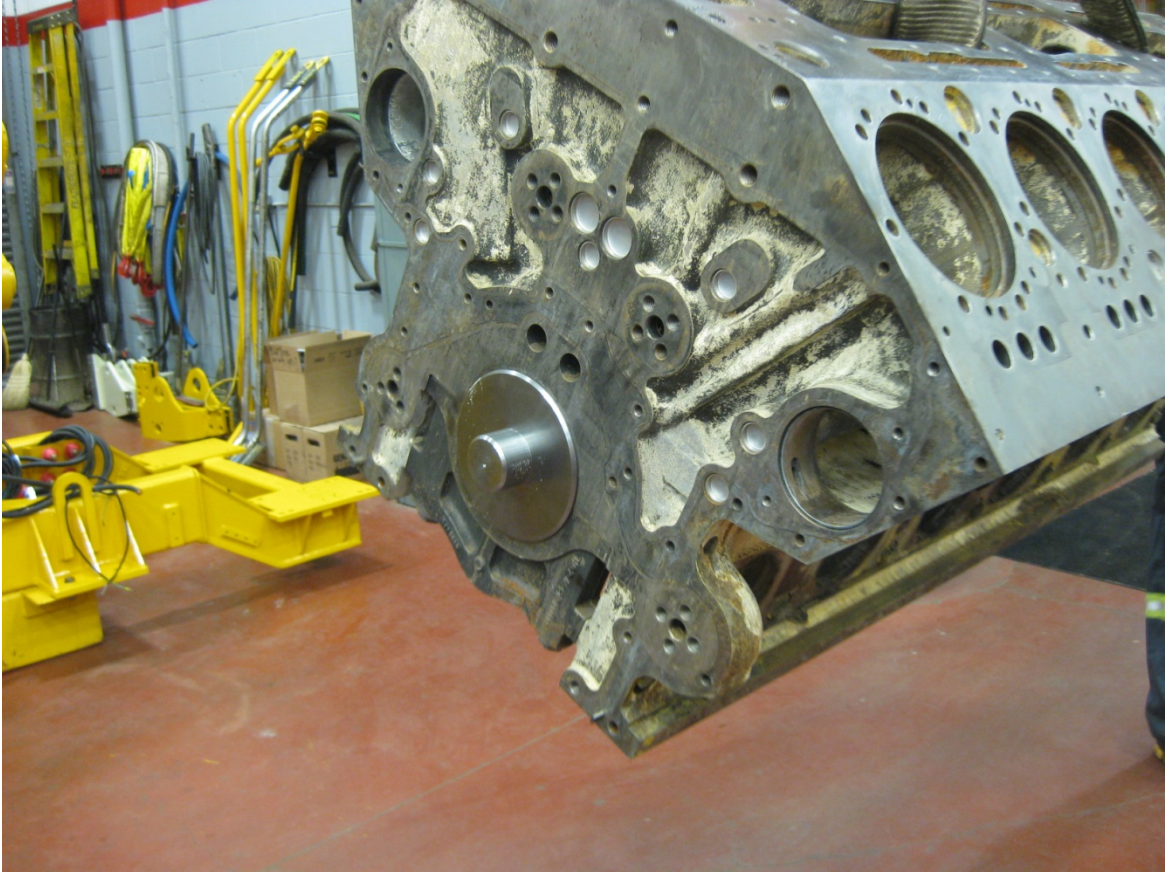



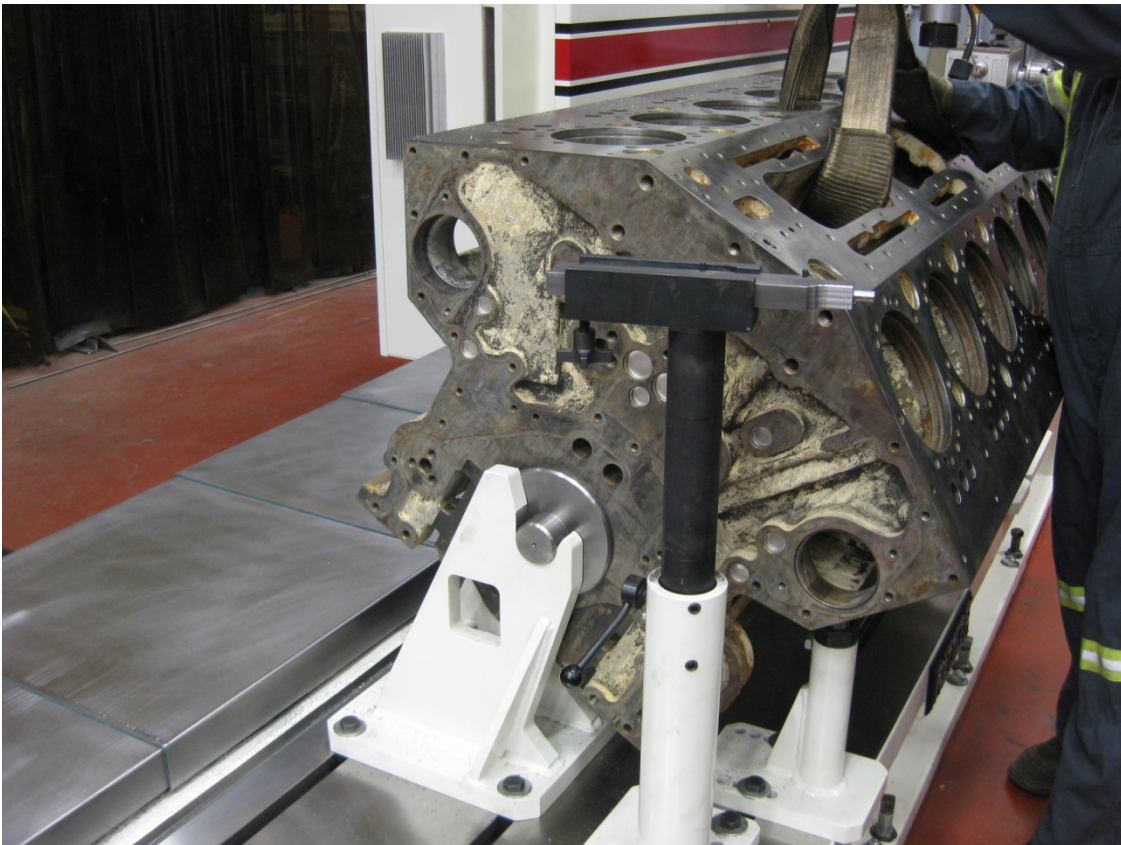

6810 Waukesha 7042, 9390 and CAT 379, 398, 399 Block Line Bore Fixture:

This fixture is designed to be mounted directly on the bed of an F90 machine. Due to the large size of the Waukesha 7042 block, care must be taken when loading and unloading to avoid bumping the block into the column or spindle unit.

⚠ WARNING

Handle these large blocks with Extreme care and guidance. A block hoist is required when handling these blocks.

Use the diagram on the following pages when referring to part numbers listed below. This Line Bore fixture consists of a stationary cradle and an adjustable support. The Cradle (6811A) is mounted to the machine bed over the locating pivot key and pin assembly. The locating pivot pin (6819) is pressed into the locating pivot key (6820). This assembly is positioned in the center keyway of the machine bed and the (2) set screws (MF-72) are tightened to lock the key in place. The Cradle is positioned over the pin and mounted to the machine bed. With the mounting bolts installed but not tight this provides a standard pivot point for the Cradle.

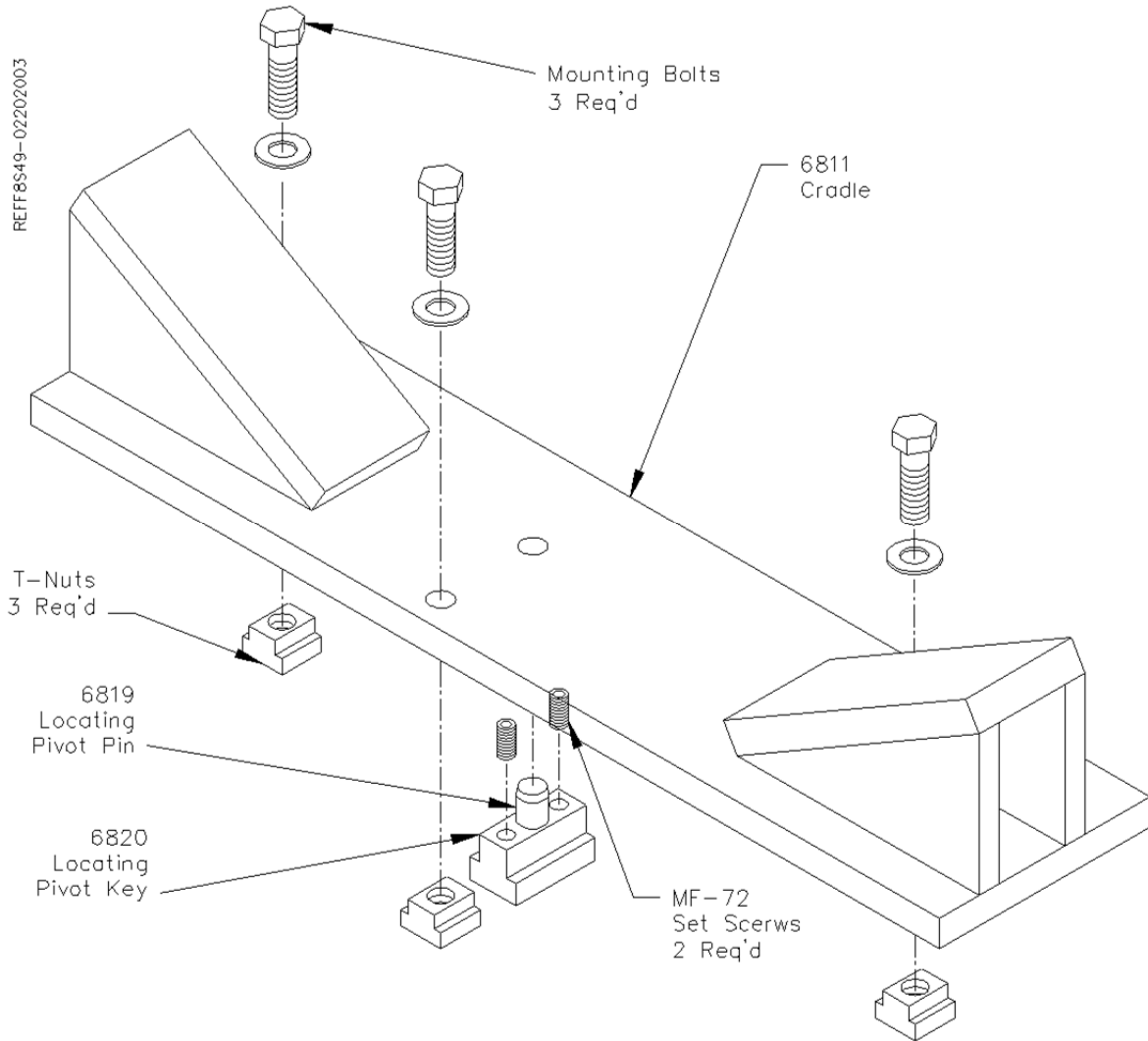

The support (6812A) is assembled with the adjusting screw (6754V) and the adjusting block (6814). This assembly is mounted to the machine bed with the lower tab of the adjusting block in the center keyway. **Be sure to install the special ratchet adjusting wrench prior to setting this assembly on the machine bed**

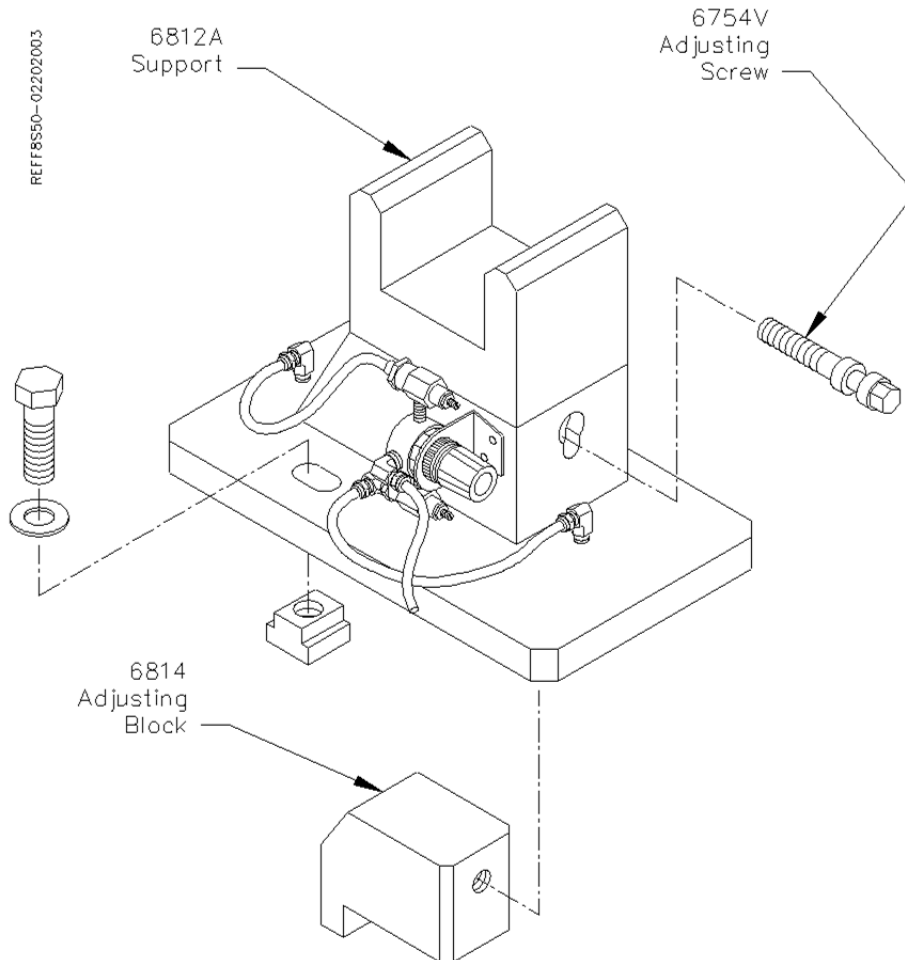

The adjustable tube (6813) is bolted to the Waukesha Block using the Cam Bearing Cap mounting holes. The adjustable tube has ten (10) holes drilled in it. Four (4) of the holes are used to bolt the adjustable tube to the engine block, the remaining six (6) holes are clearance for the cap alignment dowel pins in the engine block. Since the Cam Bearing Caps are not evenly spaced along the block, the adjustable tube must be mounted on the front end of the block as shown in the following illustration.

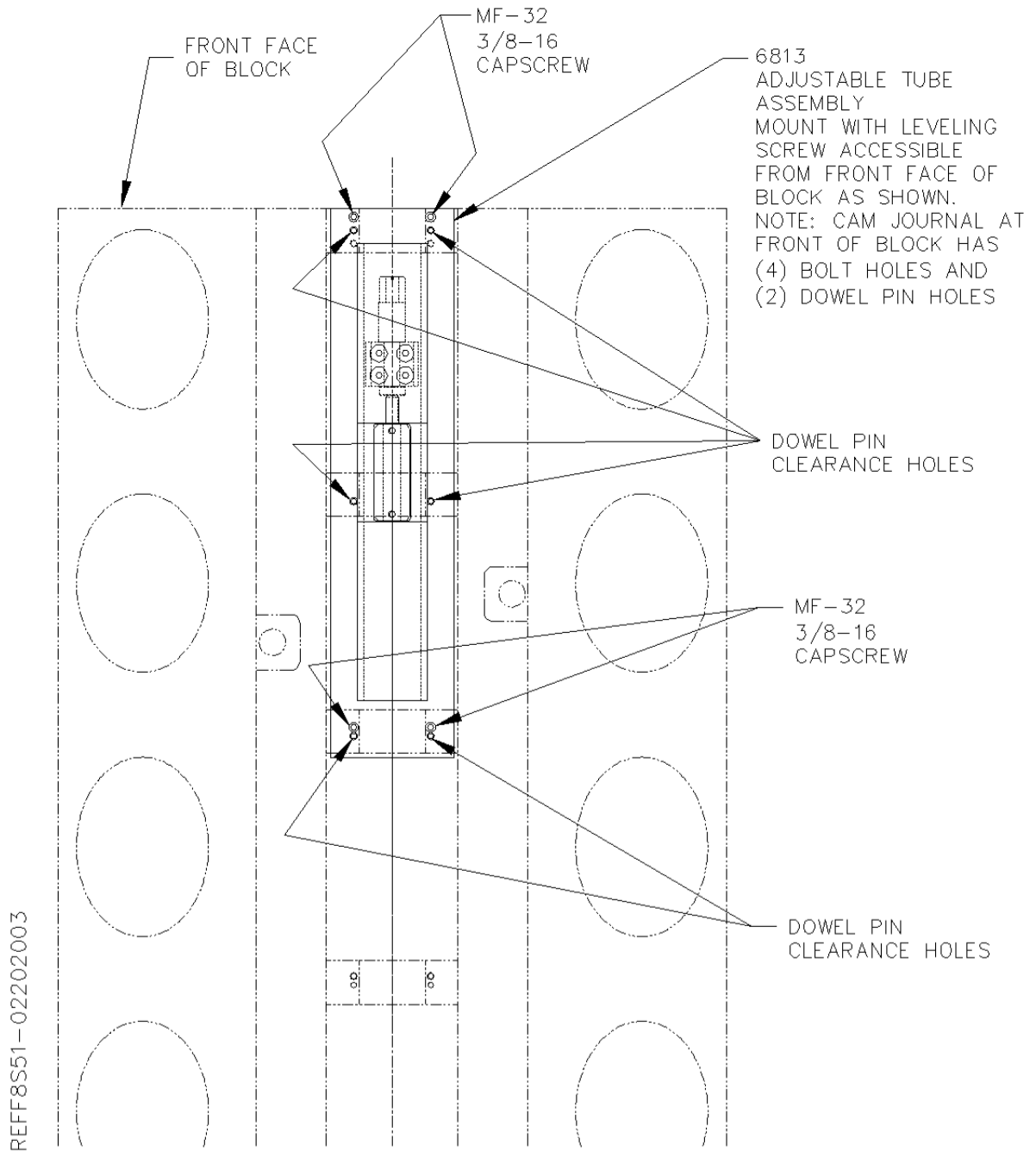

The upper and lower leveling pads, bracket and screw are already installed in the adjustable tube.

With the adjustable tube installed, the block is ready to be lowered into the Cradle and Support. Use caution to locate the adjustable tube correctly on the support. The two roll pins (MF-229B) installed in the lower leveling pad (6411) are designed to locate the leveling pads properly.

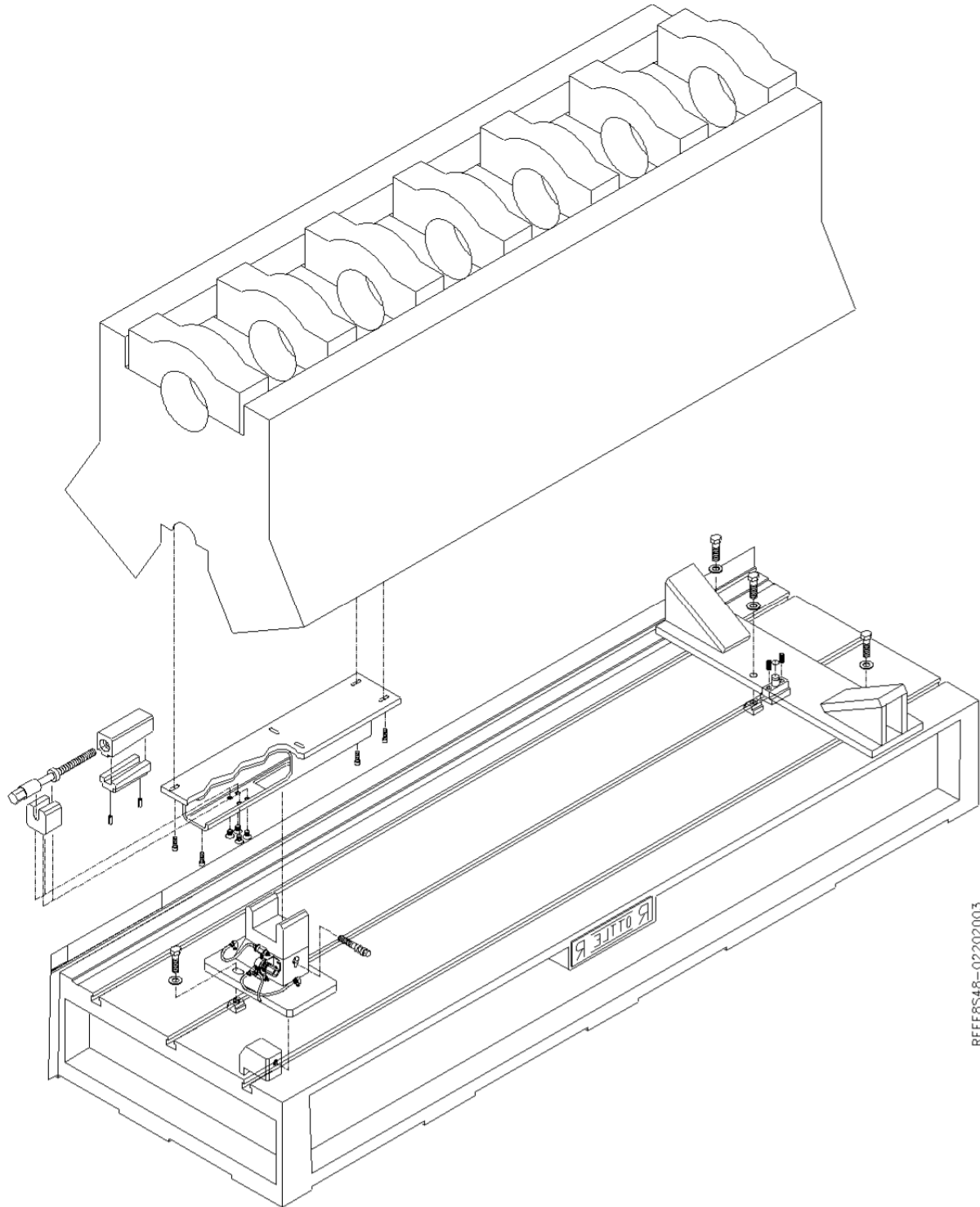

REF F8S48-02202003

All mounting bolts should be loose to start with. Due to the design of this fixture the Cradle end of the block is stationary both in relationship to the machine bed key way and in height. This end is not adjustable. The adjustable end of the fixture is located on the same machine bed keyway as the cradle. Once the block is loaded into the fixture it is ready to be aligned for the line boring operation. Up and down adjustment is accomplished using the leveling screw (6408) inside the adjustable tube. The block is adjusted in and out by activating the air float on the support, and turning the adjustment screw using the previously installed ratchet wrench. Once the block is located in and out deactivate the air float and tighten the support end mounting bolt to lock into

place. Tighten the three (3) mounting bolts on the Cradle end of the fixture now. The alignment of the block should be checked again at this time. Repeat alignment adjustments as needed.

6821 Adjustable, Universal Line Bore Parallel Assembly:

This fixture is designed to be mounted directly on the bed of the F90 series machine.

Due to the large size of these blocks, care must be taken when loading and unloading to avoid bumping the block into the column or spindle unit.

▲ WARNING Handle these large blocks with Extreme care and guidance. A block hoist is required when handling these blocks.

Use diagrams on the following pages when referring to part numbers listed below. This Line Bore fixture consists of a stationary parallel and an adjustable parallel used in conjunction with a cradle that fits the block to be machined.

Install the 6820 Pivot Key (with Pivot Pin already pressed in) into the center keyway on the right hand side of the F90 bed. Tighten the two MF-72 set screws down. This will hold the Pivot key in place while the parallel pivots on the Pivot Pin (6819). Place the parallel onto the pivot pin, install the mounting bolts and washers but do not tighten down.

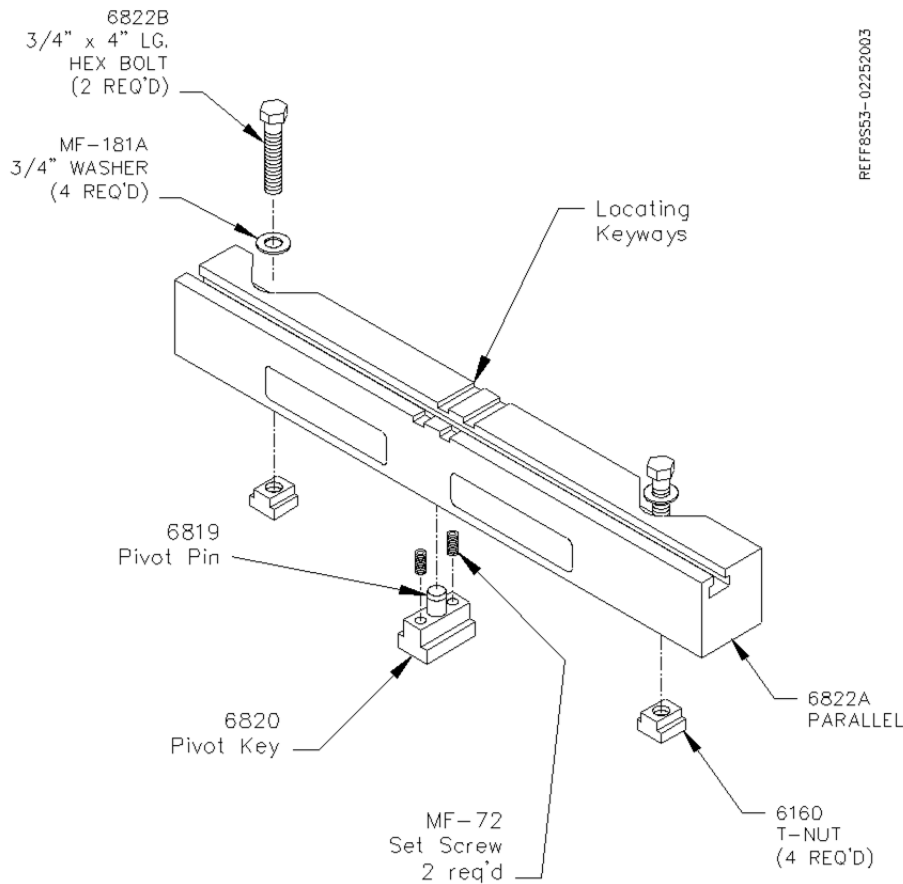

Install the adjustable parallel onto the left hand side of the F90 machine bed with the In/Out adjusting block (6830) located in the front keyway. Install the mounting bolts and washers but do not tighten down.

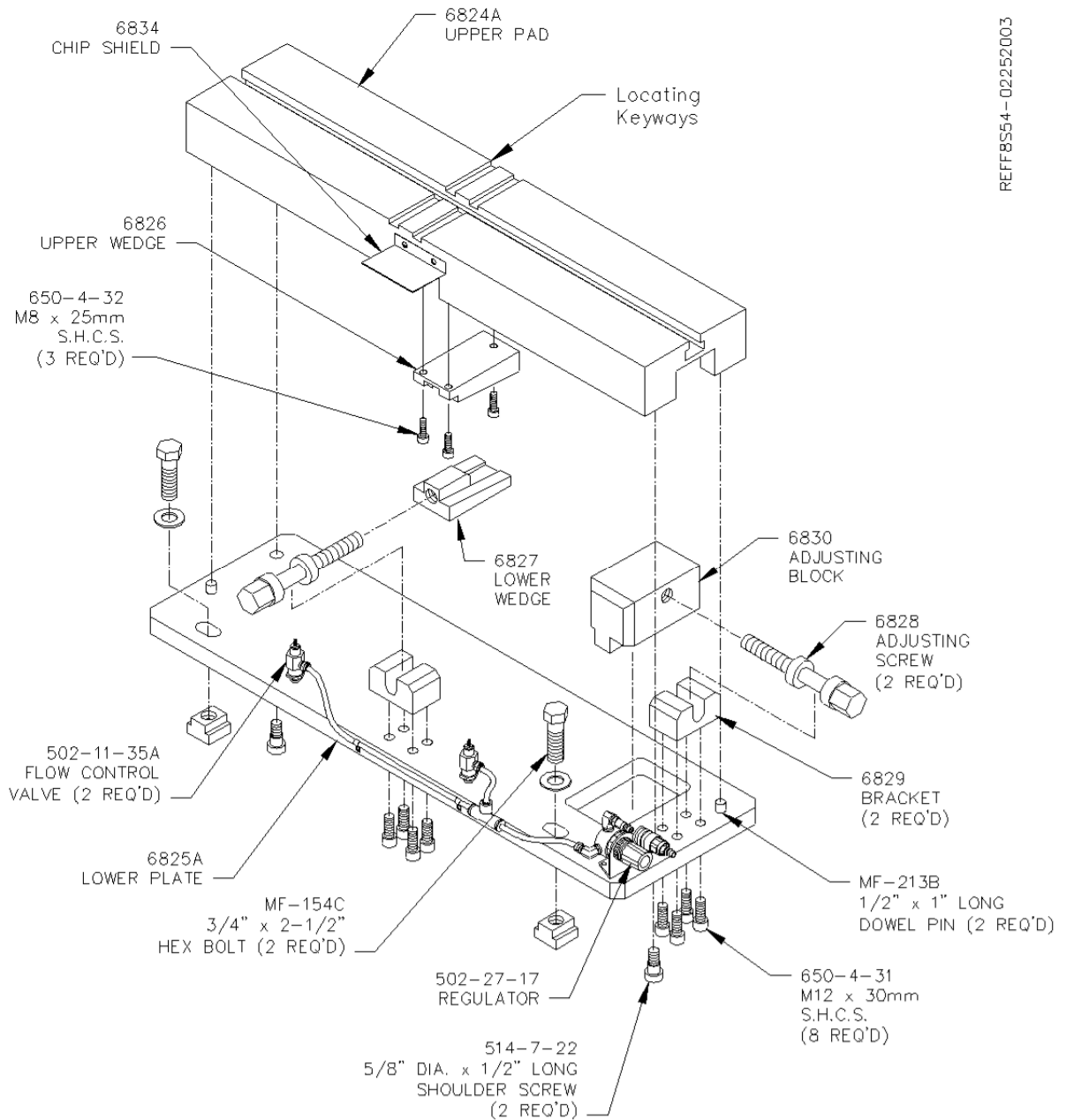

REFFB554-02252003

Once both parallels are installed on the machine bed, place a magnetic indicator on the spindle towards the main bed. Indicate the adjustable parallel into the stationary parallel to within .002" on the In/Out and height. This lines the fixture up close so the block can be loaded and then use minor adjustments on the fixture to line the block up.

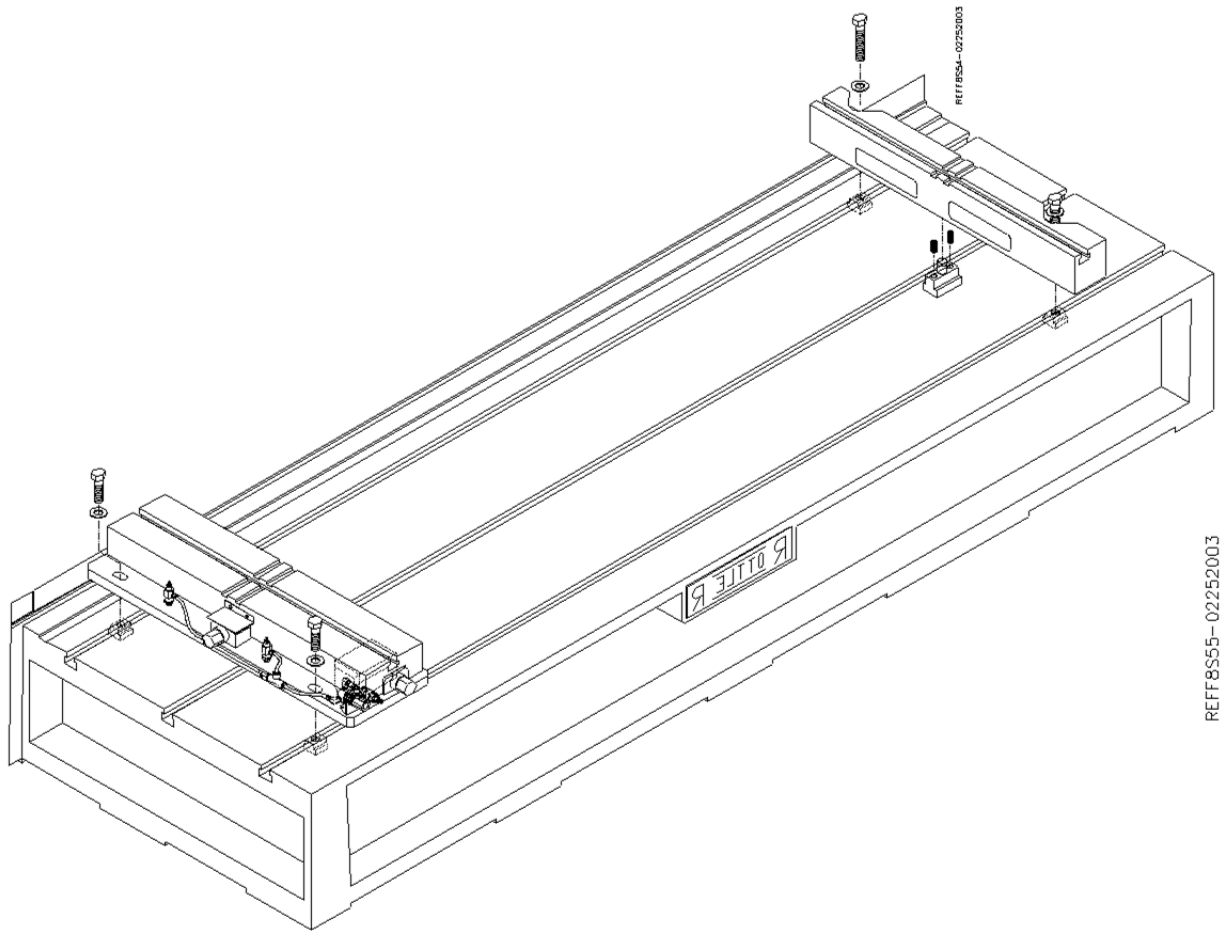

Select the set of V cradles for the block you are going to be machining. There are various types of cradles that can be used on this fixture. There are risers available also that can be mounted to the cradles to accommodate certain blocks. For cradle and riser selection refer to the Options section of this manual. The CAT 3500 series cradle is shown in this example.

Place the cradles on the parallel. Line up the horizontal key on the cradles with the key slot on the parallels. Generally, the rearward key slot is used, but on large blocks such as the CAT 3500, it is necessary to use the front key slot to allow clearance between the machine column, and engine block. Install mounting bolts and lock the cradles down. Due to the extreme weight of these blocks, clamping is usually not required. Threaded rods and clamp bars bridged across the cylinder bore, and threaded into the cradles is a way to secure the block if desired.

For in-line blocks, cradles are not used. In this case, round locators are bolted directly to the parallels. Lower the block with the end cylinders over the locators and push the block towards the front or rear. This will position the block in a straight line with the machine travel. Secure with threaded rods and clamp bars bridged across the cylinder bore, and threaded into the locators.

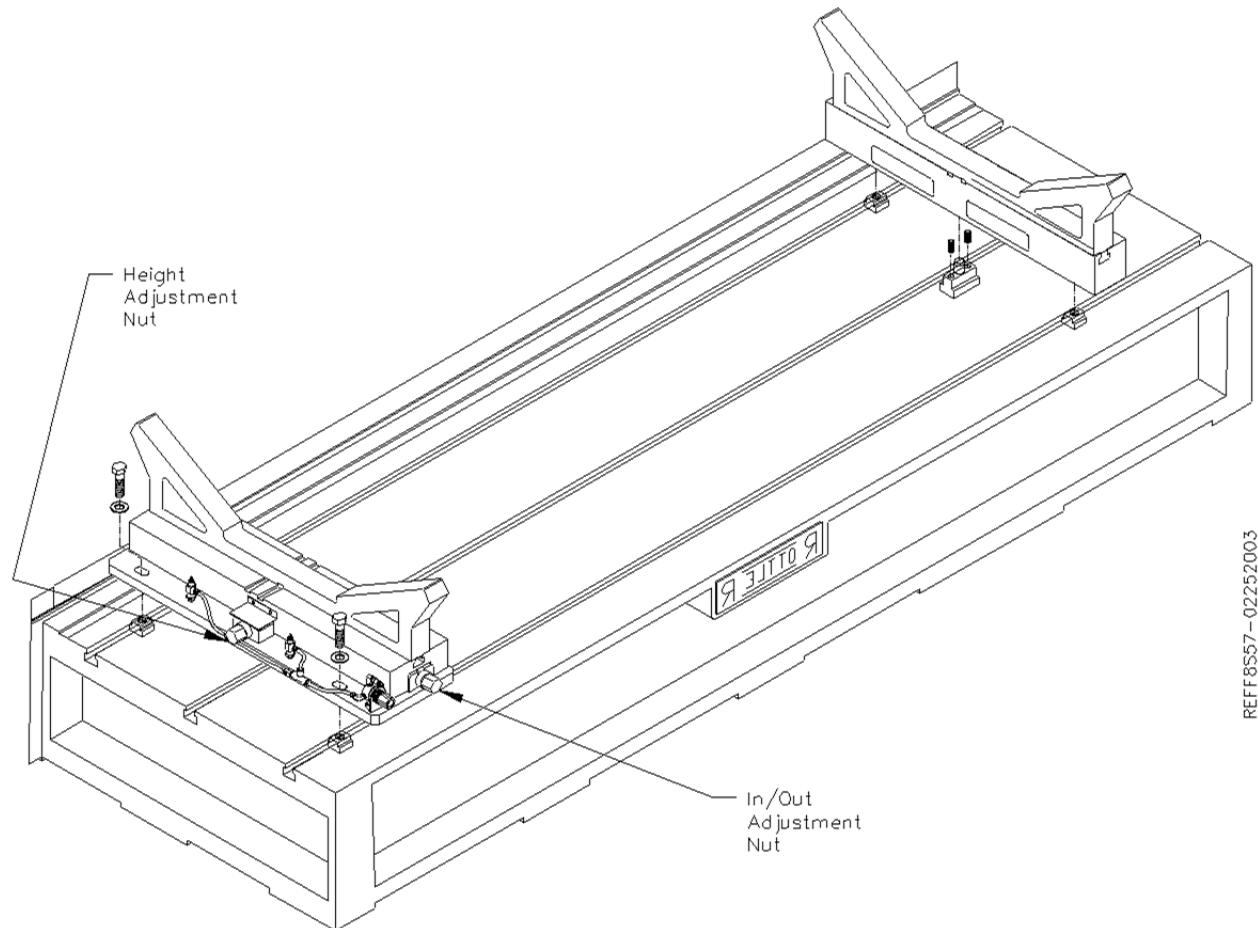

Lower the block slowly down into the cradles. Using a heavy soft mallet, tap the sides of the cradles to allow the block to settle into position. The block is now ready for alignment.

Up and down adjustment is accomplished by turning the screw on the side of the adjustable parallel. The in/out direction is adjusted by turning screw at the front of the adjustable parallel. Apply air pressure to the fixture while adjusting the in/out direction. Once the block is aligned, tighten down the fixture bolts and recheck alignment. Readjust as necessary.

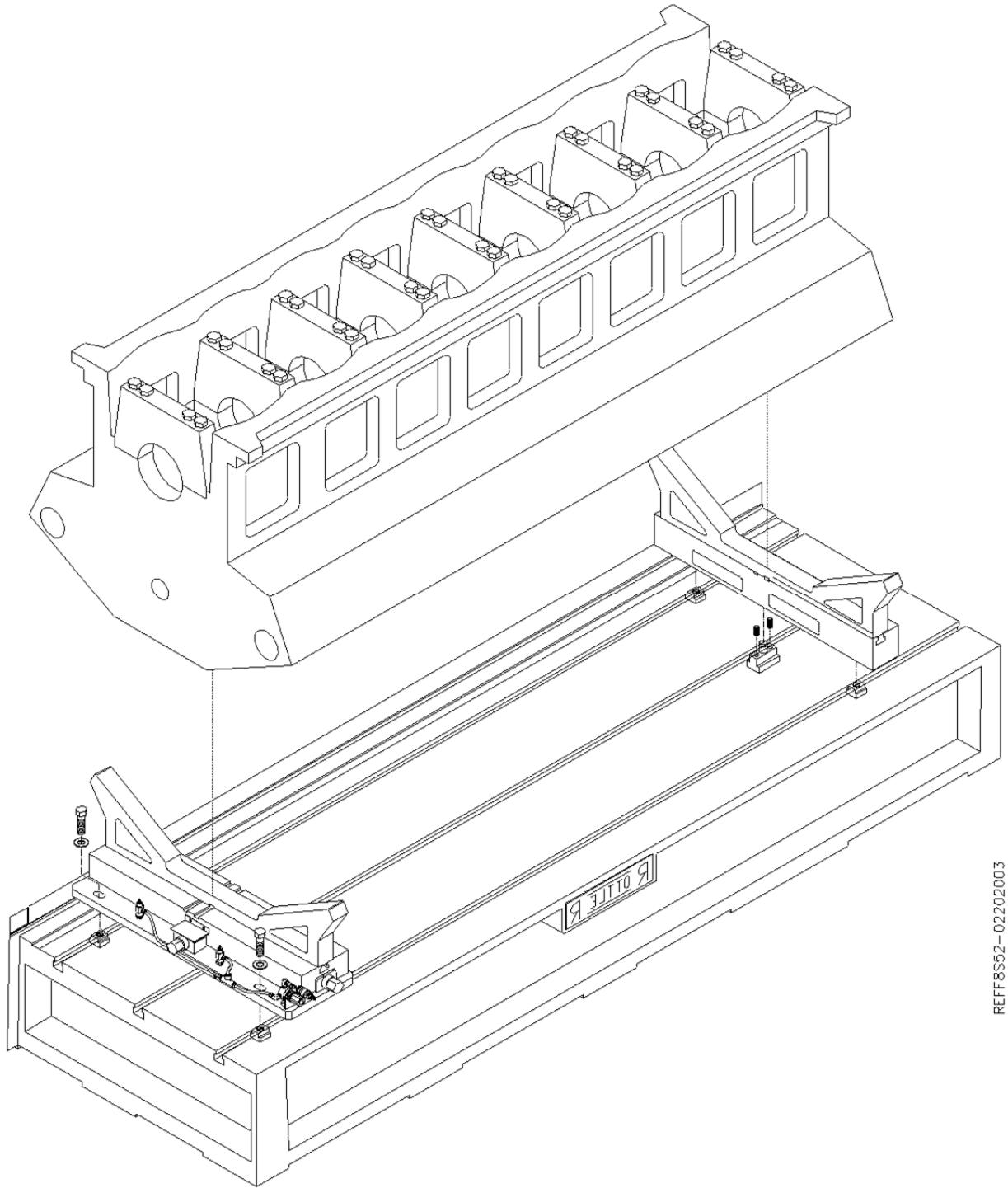

REF F8552-02202003

7119V Dual Axis Table Assembly:

REFBUL90-120197

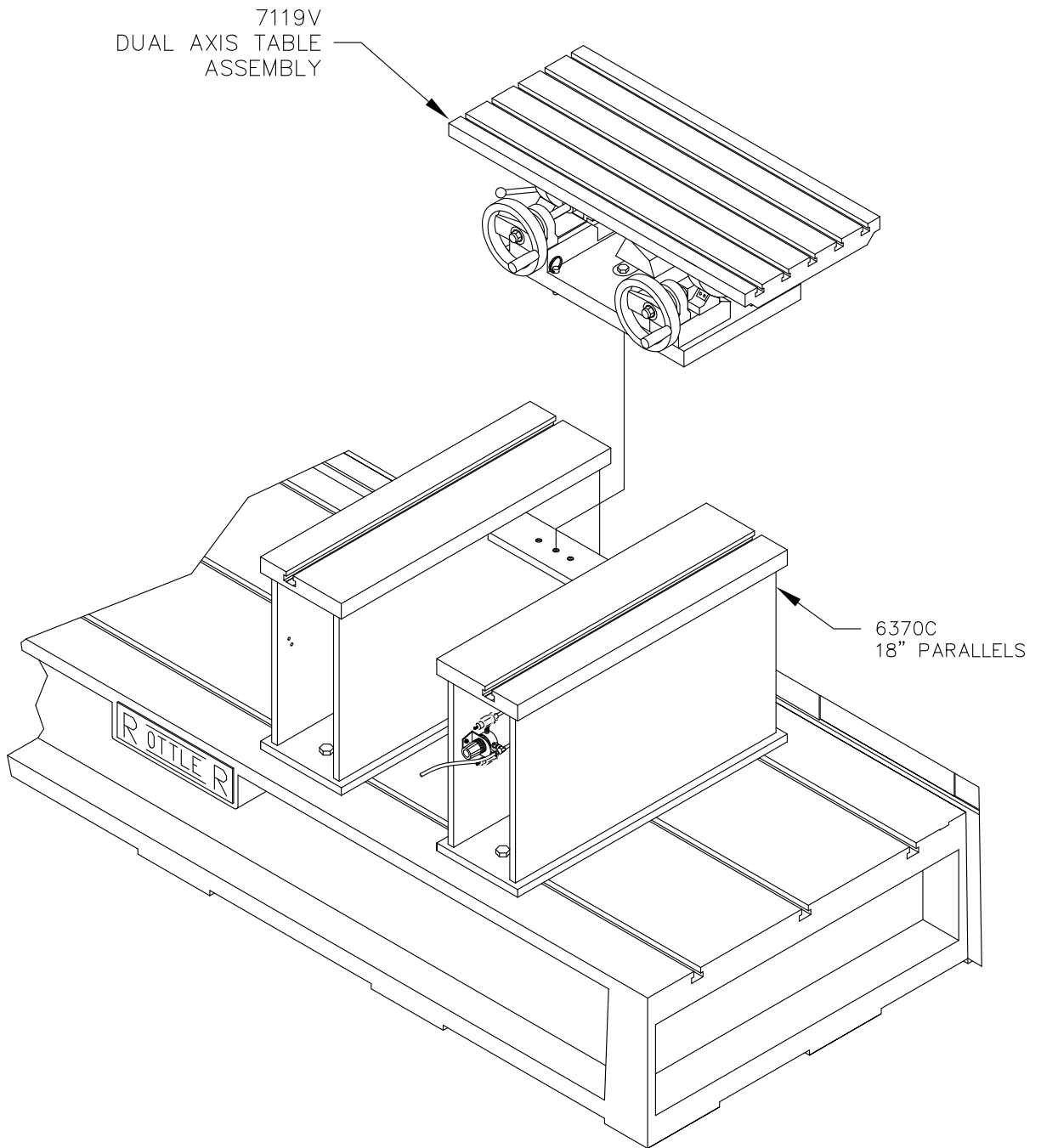

Instructions for Small In-Line Blocks:

The Dual Axis Table has the capability of holding small (less than 13 ½" from pan rail to head surface) in-line cylinder blocks for resurfacing. This will require the use of parts from the 7119P Universal Head Fixturing package.

Mounting Block to Table:

There are two (2) methods for mounting blocks to the Table. Blocks with the main caps removed or with the raised main bearings can be mounted directly to the table surface. Block with the main bearing caps installed which are lower than the pan rail surface must be mounted using support blocks from the Universal Fixturing package.

Blocks with Main Caps Removed or Raised Main Bearings:

Remove any burrs from pan rails of block.

Locate cone washers on table to approximately center block in path of cutter-head and 'hook' the edge of the pan rail in the rear. Clamp the block using clamp handle assembly. We suggest you install the stop rod assembly on the left hand end of the block. This is an added safety precaution.

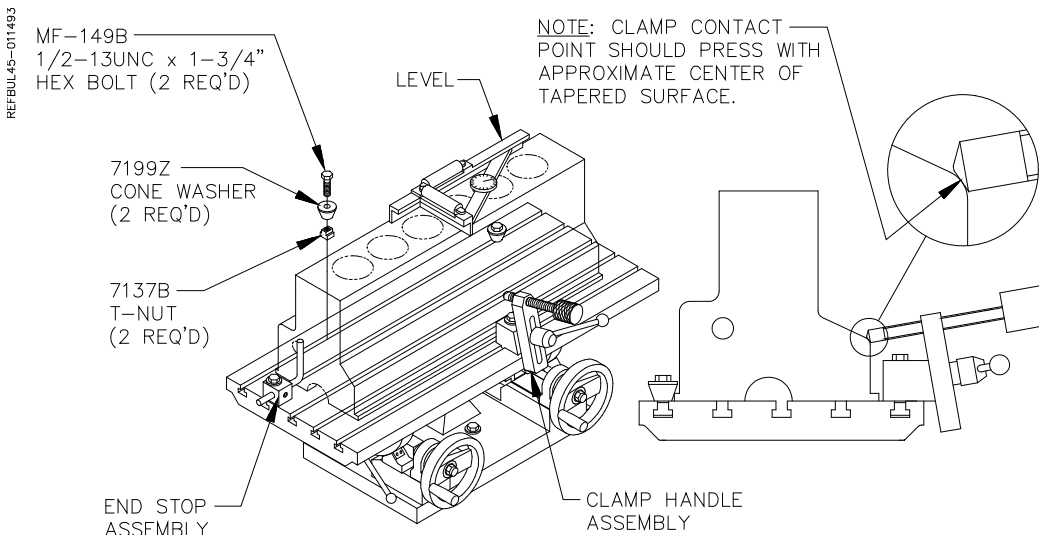

Check that all bolts and holdowns are tight. Loosen table clamp and level head surface of block in both directions. Lock table clamp and recheck block for level.

Blocks with Main Caps Installed:

Remove any burrs from pan rails of block.

Position rear supports and front supports to hold block approximately centered in path of cutter-head. Generally, place the front supports closer together than the rear supports.

Place the block on the supports. Reposition the supports if necessary to clear main caps. Etc. Elevate the cones to hook the pan rail in the rear. Tighten set screws to lock cones in place. Tighten the hex bolts on the supports. Adjust the support block jack to eliminate any rocking. Lightly apply the clamp handle assembly.

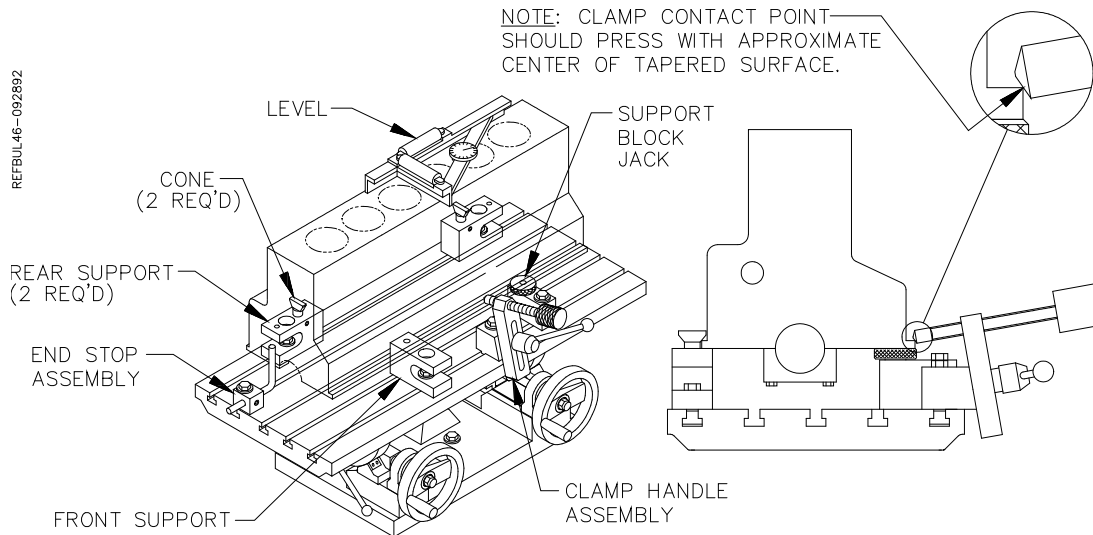

Loosen table clamp and level head surface of block in both directions. Lock table clamp. With the level still on the block tighten clamp handle assembly with appropriate clamp nose on the lower portion of a port or indent near the middle of the block. Tighten the clamp 1/8 to 1/4 turn after contacting the block. Do not over-tighten. Watch the level as you tighten to check for movement or warping. If the block moves or warps, repositioning the front supports inward will generally solve the problem. Check to see that the block cannot be moved in the fixture. We suggest that you install the stop rod assembly on the left hand end of the block. This is an added safety precaution.

Typical Head Set Up Procedure:

Find the desired ports or bosses, in the head, to position cones (long or short) on rear support blocks. Measure the distance between the centerlines of these ports (bosses) within 1/16" (1mm – 5mm). Measure the distance from rear support points to front support points on the head.

REFSETUP1-022594

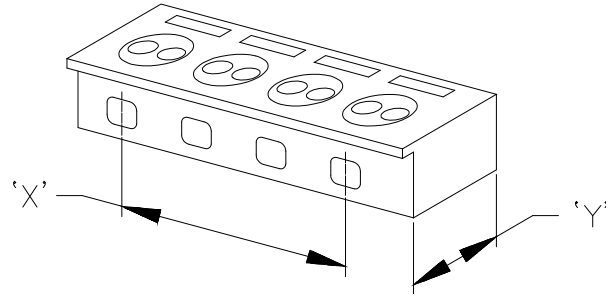

Position rear support blocks and front support blocks to hold the head approximately centered on the table top and spaced apart per dimensions measured in step '1' above. Generally, place the front blocks closer together than the rear blocks. If necessary, use either 2 or 4 spacers to raise the head for clearing studs or to angle the head so the cutterhead clears the head clamp handle assembly.

REFSETUP2-092292

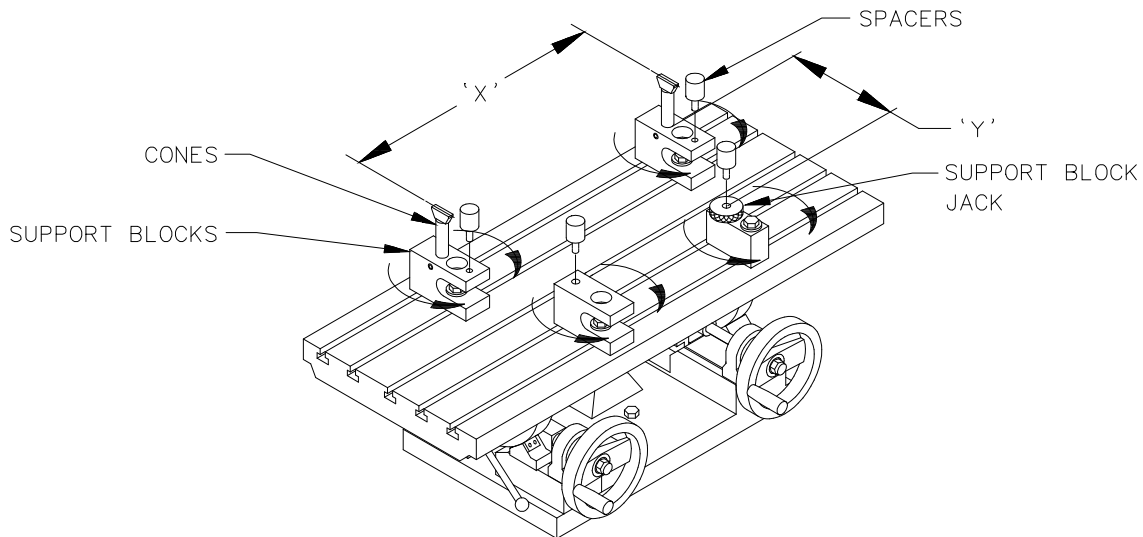

Place the head on the support blocks. Elevate the cones to 'hook' the two ports (bosses) on the head and tighten their set-screws. Adjust the position of the front support blocks if necessary. Tighten the hex bolts on the support blocks. Push the head back firmly into the cones. Adjust the support block jack to eliminate any rocking of the head. Do not tighten the head clamp handle assembly yet.

Unlock the table. Using the two hand-wheels, level the head surface to be cut. Lock the table in this position.

REF SE TUP3-092292

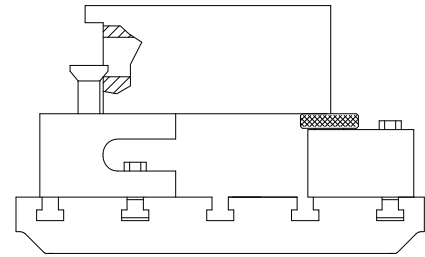
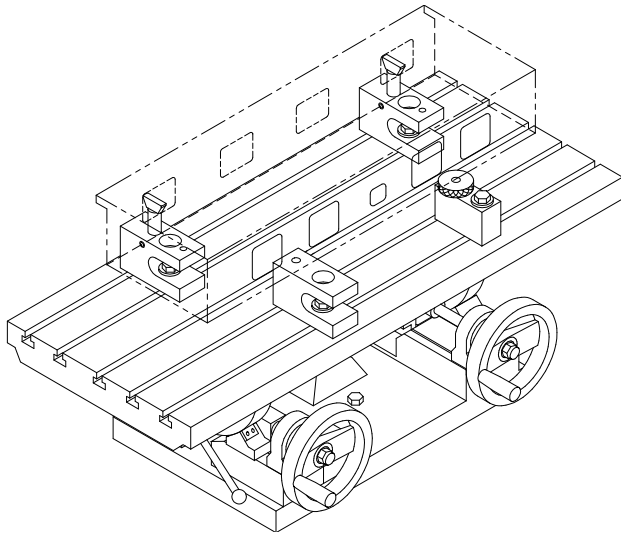

The head clamp handle assembly has a replaceable nose that pushes on the head. With the level still on the head surface, tighten the head clamp handle assembly on the lower edge of a port or indent near the middle of the head. Tighten the clamp 1/8 to 1/4 turn after contacting the head. Do not over tighten. Watch the level as you tighten to check for movement or warping. Some heads are very sensitive to support block placement, and the front support blocks may have to be moved slightly inward to prevent this warping. Check to see that the head cannot be moved in the fixture.

Slide the end stop block up against the left end of the head towards the rear. If possible, rotate the stop rod to contact a machined area on the end of the head. This will aid in loading a run of similar heads.

REF SETUP4-123192

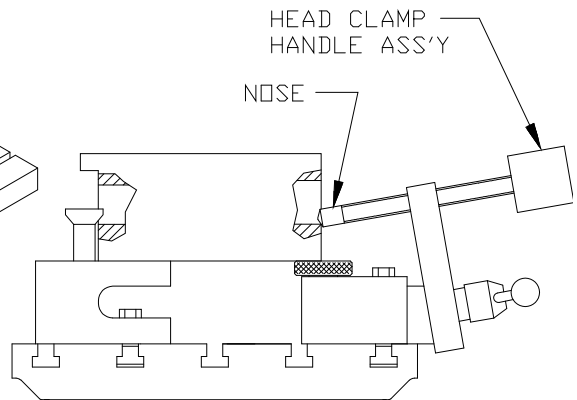
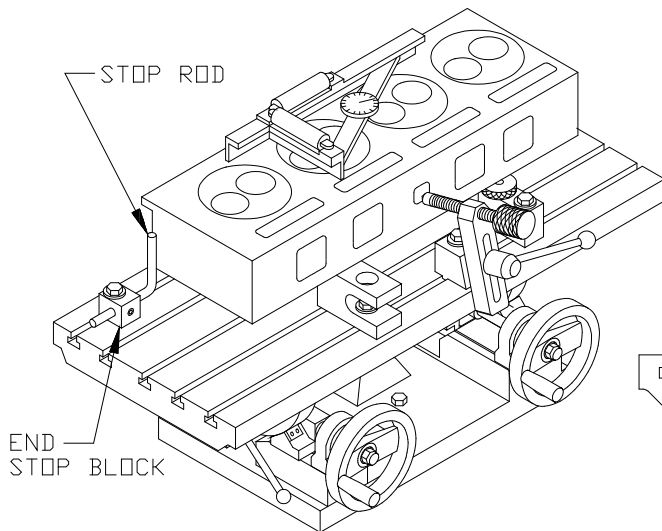

Visually check for clearance between the cutterhead and head fixture tooling pieces, especially the head clamp handle, assembly. The head should be approximately centered in the path of the cutterhead.

REFSETUP5-022594

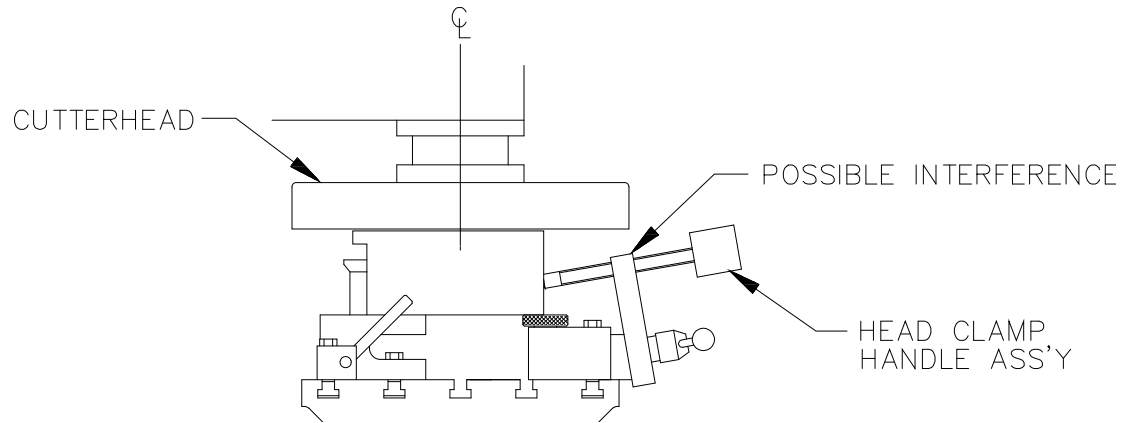

12" Multi Tooth Milling Head - 6865

This milling head holds 14 insert cartridges. Each insert has 10 cutting edges, 5 on each side. The inserts need to be adjusted to be at equal height of each other to within .0004" (.01mm). To set the height of the inserts, install the milling head into the machine spindle. Install the inserts. Back off the small set screw above each tool cartridge. Loosen each tool cartridge, push up, and re-tighten.

Using an indicator with a large diameter convex tip, find the insert that is at the lowest setting. Now, adjust the remaining inserts to equal height by turning the small set screw above each tool cartridge.

There are a couple spindle motor parameters that need to be changed to gain more torque that this milling head requires.

Go to "Set up", then "General Options".

Find the line labeled "Spindle".

Find the column labeled "Position Gain", and change it to 10. (Record the original setting before changing)

Find the column labeled "Velocity Gain", and change it to 600. (Record the original setting before changing)

100 to 120 RPM and a feed rate of .020"(.05mm) to .040"(1mm) is recommended. Maximum depth of cut .020"(.05mm)

When finish with the machining operation, re-enter the original spindle motor settings as recorded earlier.

18" Multi Tooth Milling Head 6864

This milling head holds 9 insert cartridges. Each insert has 10 cutting edges, 5 on each side. The inserts need to be adjusted to be at equal height of each other to within .0004" (.01mm). To set the height of the inserts, install the milling head into the machine spindle. Install the inserts. Back off the small set screw above each tool cartridge. Loosen each tool cartridge, push up, and re-tighten.

Using an indicator with a large diameter convex tip, find the insert that is at the lowest setting. Now, adjust the remaining inserts to equal height by turning the small set screw above each tool cartridge. Install the dampener band around the perimeter of the milling head.

There are a couple spindle motor parameters that need to be changed to gain more torque that this milling head requires.

Go to "Set up", then "General Options".

Find the line labeled "Spindle".

Find the column labeled "Position Gain", and change it to 10. (Record the original setting before changing)

Find the column labeled "Velocity Gain", and change it to 600. (Record the original setting before changing)

Find the column labeled "Accel Rate", and change it to 2. (Record the original setting before changing)

70 to 90 RPM and a feed rate of .020"(.05mm) to .040"(1mm) is recommended. Limit the depth of cut to .001" (.025mm) to .002" (.05mm)

When finish with the machining operation, re-enter the original spindle motor settings as recorded earlier.

General Machine Information:

Before starting to build or use any of the Rottler operating programs it is important to understand how the machine operates internally.

The Rottler F90M model uses Computerized Numeric Control (CNC). The CNC is always operating when the machine is turned on. However, you will not see the CNC controls unless you switch over to the CNC operating screen.

Homing:

The F90M ***MUST*** be homed anytime it is turned off. If the machine has not been homed the reference positions for all programs will be off.

The purpose of Homing the machine is to set reference points in each axis for the machine to operate from. If the machine is not homed the reference points may be off position. The reference point is set in exactly the same position each time the machine is homed. The machine keeps track of these reference positions internally and the operator will not see them.

Building Programs:

NOTE: The instructions in this section are done WITHOUT using tool or Fixture offset values.

Create a Block Program:

Block Programs are listed on the left hand side of the screen. Mode programs that are for a specific Block Model are listed on the right side of the screen.

New:

From the Program Select screen select New from the Left hand menu. This will open a window where will enter the Block name and configuration i.e. V6, V8 or Inline and number of cylinders.

NOTE: There is an existing program on start-up of new software called Part Program. This can be deleted after the first Block Program is entered.

Program Selected: Default Block	0.000	Vert	0.0000	In/Out	0.0000
Mode Selected: CL	1.00	Horiz	0.0000	4th	0.000

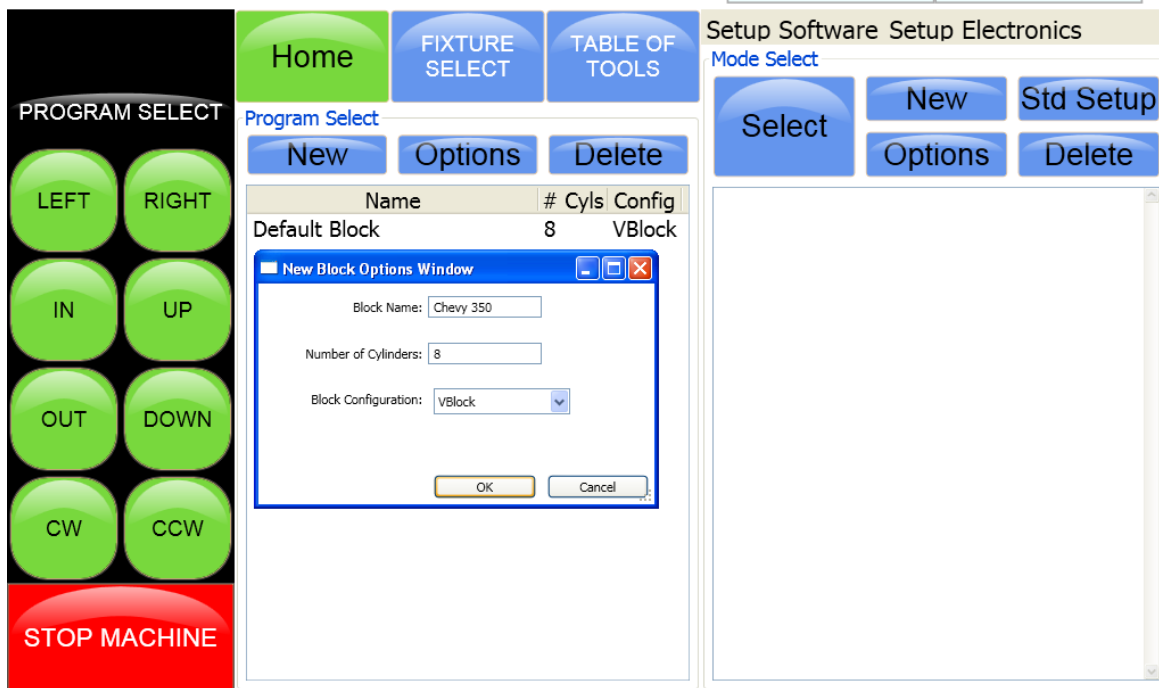

Options:

If you need to change the block configuration or name of a block that has already been created, use the Options button. This will bring up the same window as when the block was created.

Creating Operating Modes for a Block Model:

Select the Block model on the left hand side of the screen.

New:

Selecting New will bring up a window that lists all the Modes that can be performed on the selected block model. Highlight the Mode you want to create and press OK.

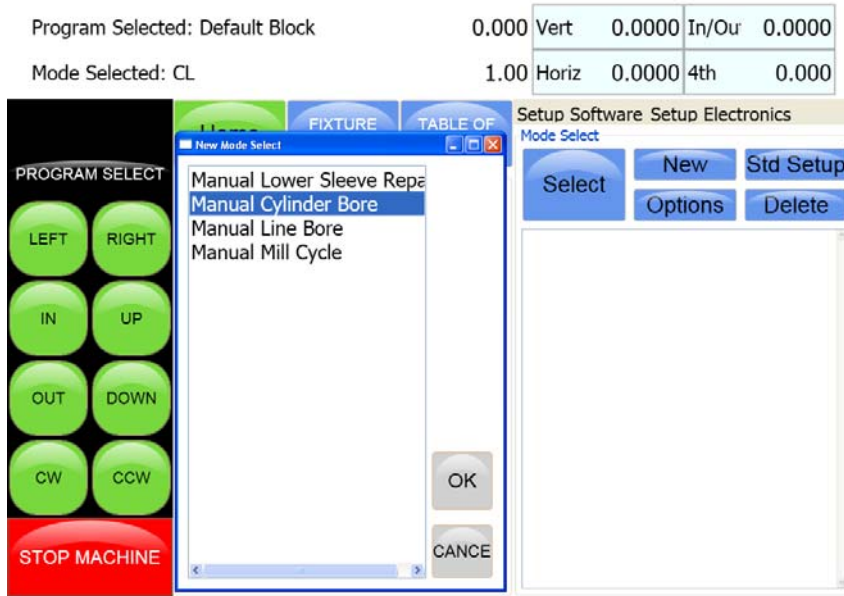

The selected mode will show up on the right hand side of the screen.



Std (Standard) Setup:

Pressing Std Setup will cause all of the available Modes to be inserted into the Modes area on the right hand side.

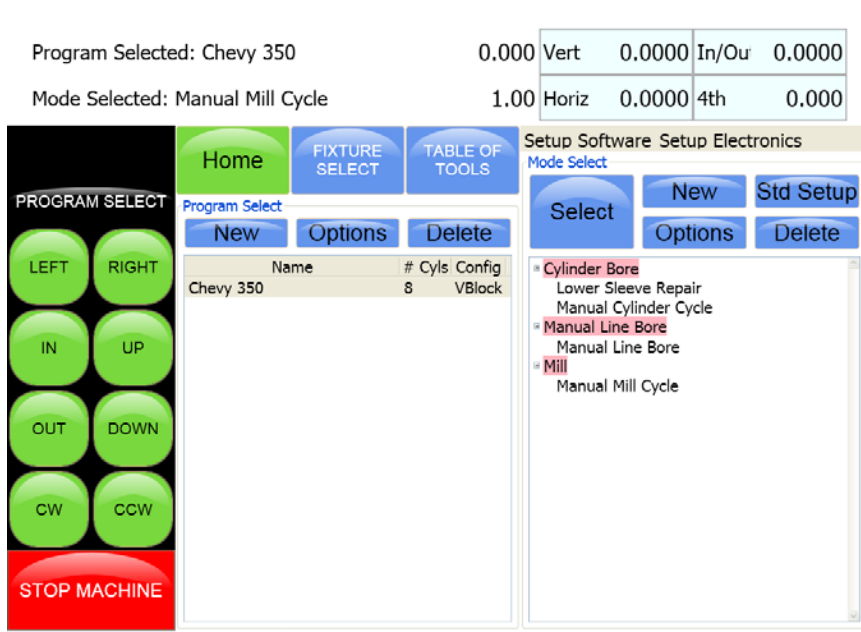

Select:

Pressing Select with a Mode highlighted will open the operations screens for using the program.

Options:

Pressing the Options button with a Mode highlighted will open a window where you can change the mode name. There is also a check box to allow positive number to be entered into the program where they are normally forced to a negative value.

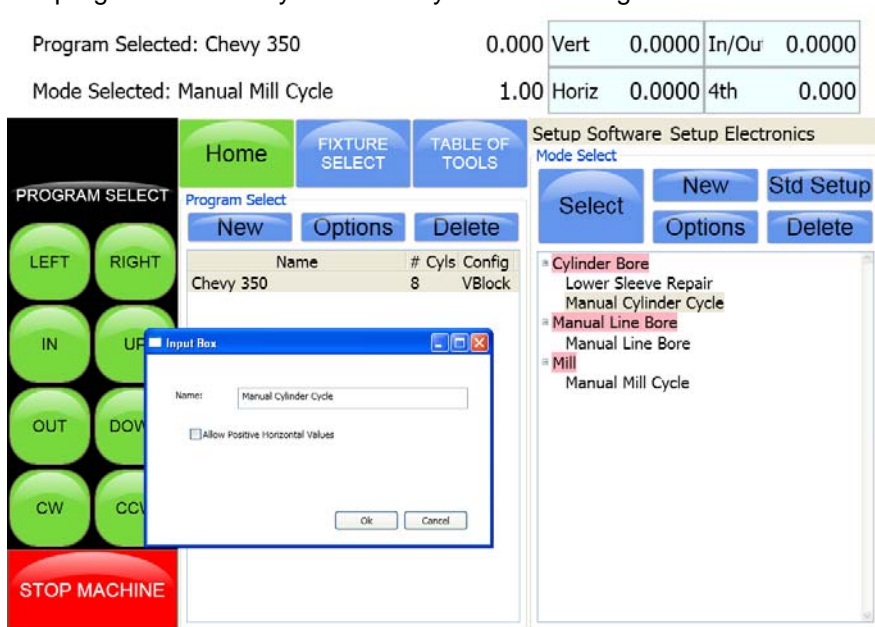

Manual Cylinder Bore:

Select Cylinder Bore and then Rough Through Bore on the screen. This will bring up the boring program with the Set Zeros tab shown.

NOTE: Once a certain feature is discussed in a particular mode it will not be discussed again in the following modes.

Program Selected: Chevy 350	0.000	Vert	0.0000	In/Out	0.0000
Mode Selected: Manual Cylinder Cycle	1.00	Horiz	0.0000	4th	0.000

Setting Zeros:

The purpose of setting zero points is to give the operator a specific point to build programs from. The machine also uses these zero points to run the program from. The zero points can be set at any point in the machines' travel. Each axis (except the Spindle rotation) will need to have a zero point set for the machine to operate from. Every program will save it's individual zero positions. The next time that program is selected the zero position will be the exact same distance from the Home position for each axis.

Horizontal and In/Out Zero:

The machine will start the Auto Cycle at the Horizontal and In/Out zero position.

Vertical Zero:

The machine will start the Auto Cycle from the Vertical zero position. You need to set the vertical zero with the cutting tool just above the work piece.

Operation:

Program Selected: Chevy 350

0.000

Vert	0.0000	In/Out	0.0000
------	--------	--------	--------

Mode Selected: Manual Cylinder Cycle

1.00

Horiz	0.0000	4th	0.000
-------	--------	-----	-------

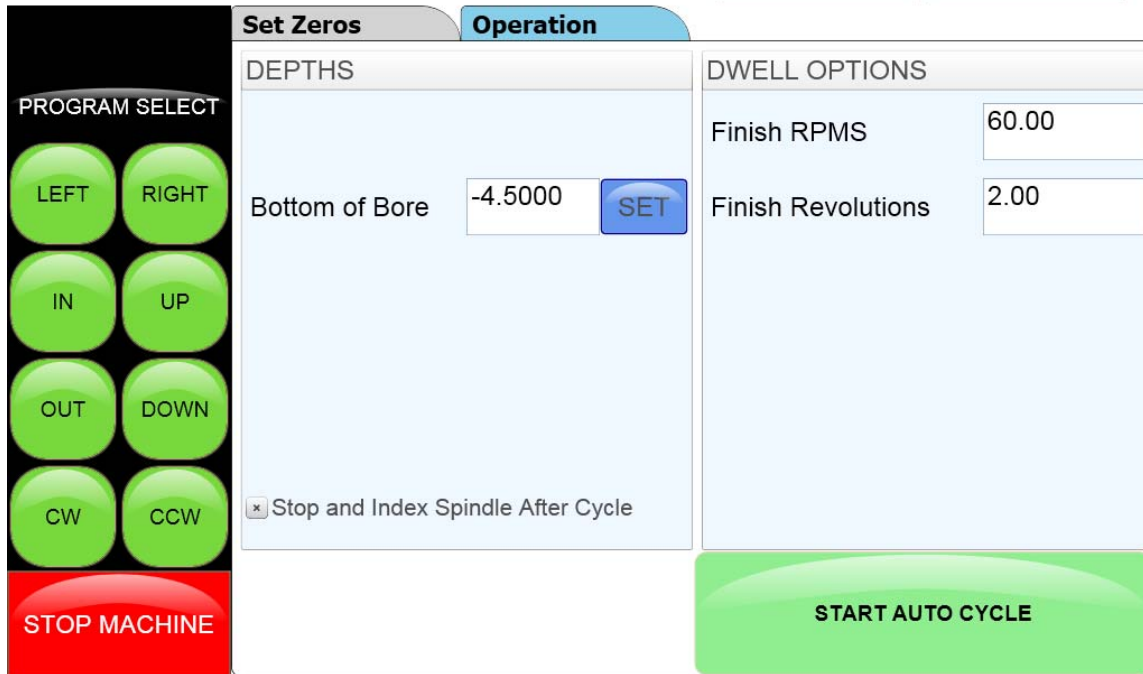

Bottom of the Bore:

This is the distance below zero or the Block deck where you want the machine to stop boring and retract out of the cylinder. When the spindle retracts it will then go to the block Clearance position.

Stop and Index Spindle after Cycle:

Checking this box will cause the spindle to be indexed to the three O'clock position after the cylinder has been bored but before it retracts. It will also offset to the left before the tool is retracted. This is the default setting. You would not want this check in an operation such as Lifter Boring.

Finish RPMS and Revolutions:

This is the RPM the spindle will turn for the set number of revolutions at the bottom of the bore. This is used to get a desired finish on a counter bore or sleeve cut.

Start Auto Cycle:

Pressing this button will start the automatic cycle. Spindle will travel vertically to the zero position. Horizontal and In/Out will then travel to the Zero position. The spindle will start at the programmed RPM on the Set Zeroes page and then feed down at the programmed Feed Rate to the Bottom of Bore Setting.

Manual Lower Sleeve Repair:

Program Selected: 3500 CAT

0.000 Vert 0.0000 In/Out 0.0000

Mode Selected: Manual Lower Sleeve R

1.00 Horiz 0.0000 4th 0.000

The screenshot displays the control panel for the 'Manual Lower Sleeve Repair' operation. On the left, there is a 'PROGRAM SELECT' panel with buttons for LEFT, RIGHT, IN, UP, OUT, DOWN, CW, and CCW, along with a red 'STOP MACHINE' button. The main interface is divided into two tabs: 'Set Zeros' (selected) and 'Operation'. Under 'Set Zeros', the 'DEPTHS' section contains four input fields: 'Start Boring Height' (value: -6.2800), 'Bottom of Bore' (value: -6.4000, with a blue 'SET' button), 'Horiz Clearance' (value: -0.1000), and 'Horiz Overshoot' (value: 0.0200). Below these is a checkbox labeled 'Stop and Index Spindle After Cycle'. The 'DWELL OPTIONS' section on the right has two input fields: 'Finish RPMS' (value: 60.00) and 'Finish Revolutions' (value: 2.00). At the bottom right, there is a large green 'START AUTO CYCLE' button.

Start Boring Height:

This should be set to a value just above the where the cut will start. The Vertical Zero should be set with the cutting tool even with the block deck.

Horz Clearance:

This is the amount the machine must offset horizontally for the tool to clear the upper bore.

Horiz Overshoot:

This is the distance for the machine to move past the Horizontal Zero when coming back from the Horizontal Clearance distance at the Start Boring position.

Bottom of Bore:

Set this value to where you want the cut to end. This is a vertical position referencing the Vertical Zero.

Start Auto Cycle:

Pressing this button will start the automatic cycle. Spindle will travel vertically to the zero position. Horizontal and In/Out will then travel to the Zero position. The Horizontal will then offset the programmed amount and direction. The vertical will then travel down to the Start boring height. The Horizontal will move back to the zero position plus the offset amount and then back to zero. This will remove any backlash. The spindle will start and then bore the programmed Bottom of Bore setting. The Horizontal will then offset the programmed amount and direction and then retract to the Vertical Zero location.

Manual Line Bore:

You will manually center the Vertical, Horizontal and In/Out on the center of the bore to be line bored.

Program Selected: 3500 CAT	0.000	Vert	0.0000	In/Out	0.0000
Mode Selected: Manual Line Bore	1.00	Horiz	0.0000	4th	0.000

The screenshot shows the machine control interface with the following elements:

- PROGRAM SELECT** section with buttons: LEFT, RIGHT, IN, UP, OUT, DOWN, CW, CCW, and a red **STOP MACHINE** button.
- Set Zeros** and **Vertical Stops** tabs.
- BORE PROFILE** section with a **Bore Length** input field set to **1.5000**.
- A large green **START AUTO CYCLE** button.

Bore Length:

This is the Width of the bore.

Start Auto Cycle:

Pressing this button will start the spindle and feed rate set in the Set Zeros page. The spindle will bore horizontally to the programmed depth and direction then retract to the zero position.

Manual Mill:

Center the milling head on the work piece in the In/Out Direction and set the zero position. Horizontally position the Mill head just to the right of the work piece and zero. Set the Vertical Zero even with the work surface. Add the desired amount of material to be removed using the handwheel and re-zero the Vertical.

Program Selected: 3500 CAT	0.000	Vert	0.0000	In/Out	0.0000
Mode Selected: Manual Mill Cycle	1.00	Horiz	0.0000	4th	0.000

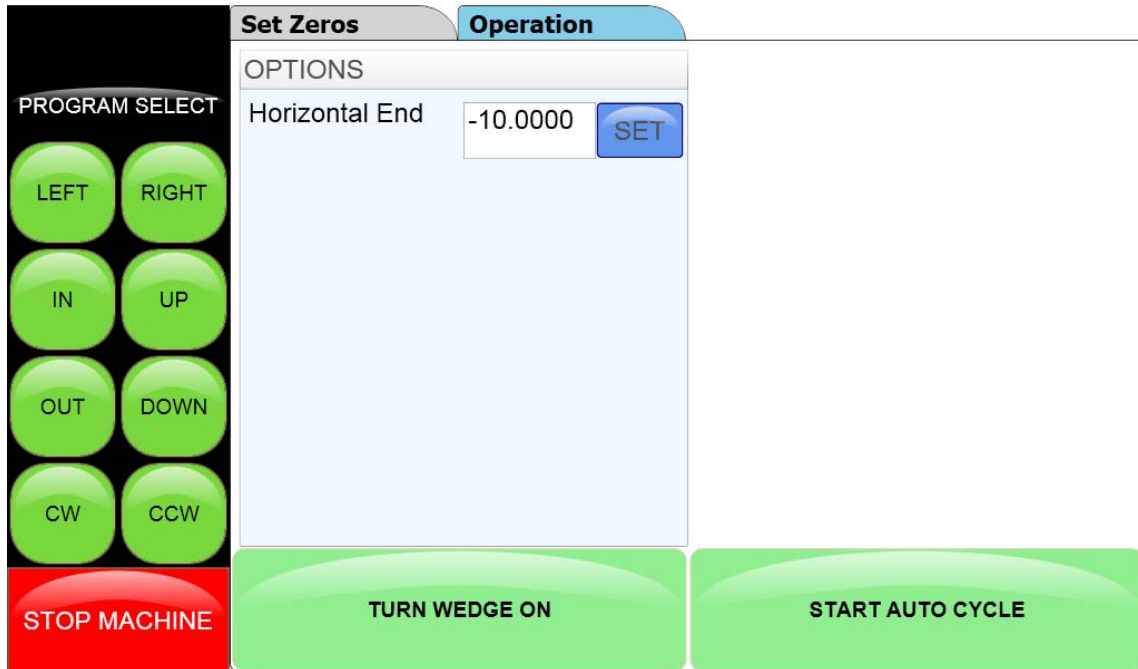

Horizontal End:

This is the length of horizontal travel that will be required to Mill the entire surface of the work piece.

Start Auto Cycle:

Pressing this button will start the automatic cycle. Spindle will travel vertically to the zero position. Horizontal and In/Out will then travel to the Zero position. The Spindle will start at the set RPM and Feed rate to the Horizontal End position.

Chapter 4 Contents

Maintenance:	2
Lubrication:	2
Outer Spindle:	2
Upper Belt Housing:	2
Oil Reservoir System:	2
Inner Spindle Bearings:	3
Vertical Ballscrew Bearings:	3
Column Feed Gear Housing:	3
Quick Reference Lubrication Chart:	3
Lubrication:	4
Lubrication:	5
Air Logic:	6
F90M Wiring Diagram 9023E Radio Probe:	8
F90M Wiring Diagram 9023E Continued:	9
502-12-7B Sony LT20 Set Up Instructions:	11
Outer Spindle Adjustment:	13
Inner Spindle Adjustment:	15
F90M Upper Housing Disassembly:	16
F90M Inner Spindle Removal:	19
Inner Spindle Angular Contact Bearing Replacement:	19
Spindle Sweep:	21
Horizontal Gibs:	22
AUTO MODE BACKLASH SETTING INSTRUCTIONS	24
HANDWHEEL BACKLASH SETTING INSTRUCTIONS	28
Spindle Belt Adjustment:	30
Preventative Maintenance Quick Reference Chart:	31
Probe "On-Center" Adjustment:	36

Maintenance:

Lubrication:

Refer to illustration following these written instructions:

Below are the directions that explain how and where to add oil to the different systems:



Do not overfill any of the lubrication points, serious electrical damage may result.

Outer Spindle:

The Outer Spindle is hard chromed and is supported in tapered, cast iron spindle bushings. The Outer Spindle supports the Inner Spindle, bearings, seals etc... and maintains the boring rigidity.

Every 8 hours:

The Outer Spindle needs to be moved down to the lower limit, wiped clean, and then lightly coated with a **light weight #10 oil**. This is very important, if the spindle is allowed to operate dirty the cast iron dust will act as an abrasive on the spindle chrome. This will cause the spindle to wear prematurely. The outer spindle is a very expensive item to replace.

Every 1000 Hours:

Open the sheet metal cover from the front of the spindle unit. There is a large nut where the outer spindle passes through the top of the spindle base. Using a spanner wrench or punch carefully remove the top spindle nut.

Note: *Do not adjust the nut below the felt wiper (see the mechanical section for correct adjustment of this nut).*

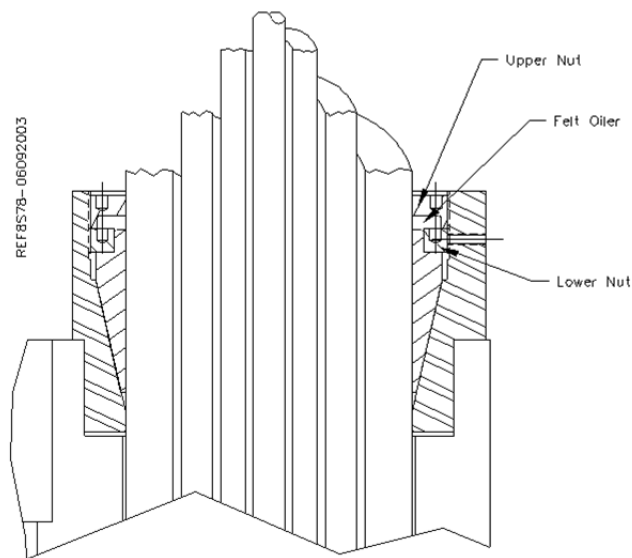

Slide the felt wiper back into place and tighten the Upper Nut back down.

Upper Belt Housing:

No lubrication is necessary in the Upper Belt Housing.

Oil Reservoir System:

IMPORTANT!! – Every 8 hours check the oil supply lines to the upper spindle to be sure they are full of oil.

The oil reservoir system is located inside the lower portion of the column. This system lubricates the following:

- Ways
- Inner Spindle Bearings (Upper and Lower)
- Horizontal Ballscrew
- Outer Spindle

Every 175 Hours:

The oil level of the reservoir should be checked, and filled with **a light weight #10 spindle oil**.

When the oil reservoir is low or empty on the F90M machine, the control will “LOW OIL” and will not run until the reservoir has been filled.

The oil system may require priming if the reservoir has been run empty. You can do this manually or automatically. To prime automatically, change the oiler machine parameter #123 to a value of 10. This will turn the oiler solenoid on every ten seconds as long as the spindle is running. Take note when the oil lines are full, reset the oiler parameter and operate the machine normally. To prime manually, open the air door on the lower left hand side of the column, locate the blue solenoid, press the manual override button on the solenoid repeatedly until the oil lines are full. You need to pause for a second between button presses to allow the valve to reset. Pressing the button too fast will not pump oil through the system.

Inner Spindle Bearings:

The Inner Spindle Bearings are lubricated from the oil reservoir system. It is normal for a small amount of this oil to seep through the spindle bearings and onto the cutterhead.

Vertical Ballscrew Bearings:

The Upper Pillow Block bearing is located on the top plate just below the driven sprocket. The lower bearing set is located at the bottom of the ballscrew in the spindle base.

Every 175 Hours:

These bearings should be greased with **Unoba EP 2 Multi Purpose Grease or equivalent NLGI 2 grease**.

Column Feed Gear Housing:

The Column Feed Gear Housing is located inside the main column. Remove the two lower inspection plates from the right hand side of the column. Located the gear housing towards the bottom (the ballscrew goes through it).

Every 1000 Hours:

Check and fill the gear housing with **76 MP Gear Lube 80w-90 (ISO VG-100-150)**. Locate the fill hole on top of the gear housing. Locate the level check hole on the side of the gear. Fill only to the level of the Check hole.

Note: If gear housing is over filled serious electrical damage may occur to the Horizontal Servo Motor.

Quick Reference Lubrication Chart:

Assembly	Frequency	Lube Operation
Outer Spindle	8 Hours	Wipe with oil
	1000 Hours	Soak felt wiper with oil
Oil Reservoir System	8 Hours	Check upper oil lines are full
	175 Hours	Fill reservoir with oil if needed
Pillow Block Bearings	175 Hours	Grease
Vertical Ballscrew Bearings	175 Hours	Grease
Swing Arm Hinge	1000 Hours	Grease
Column Feed Gear Housing	1000 Hours	Fill with oil

Lubrication:

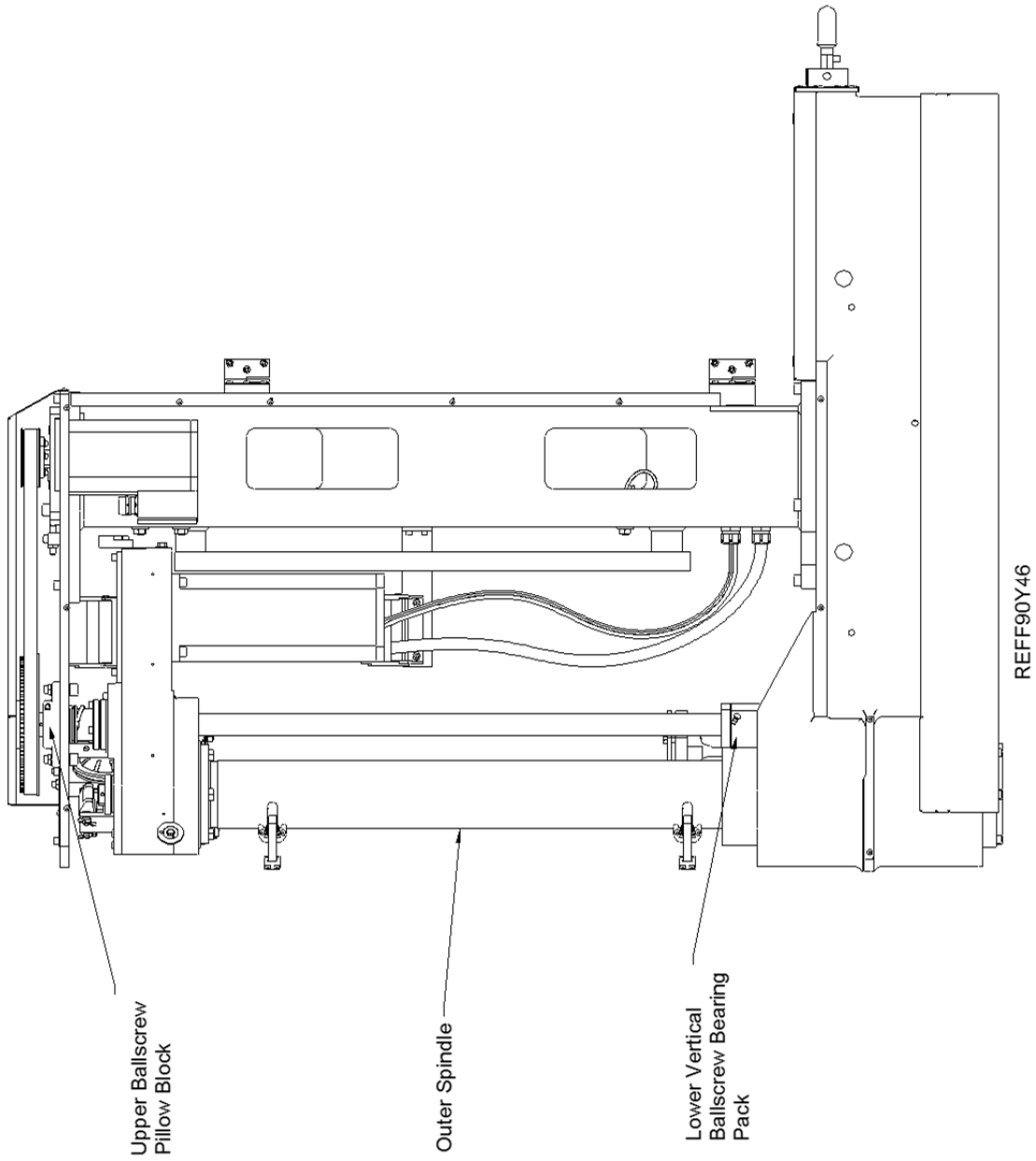

Lubrication:

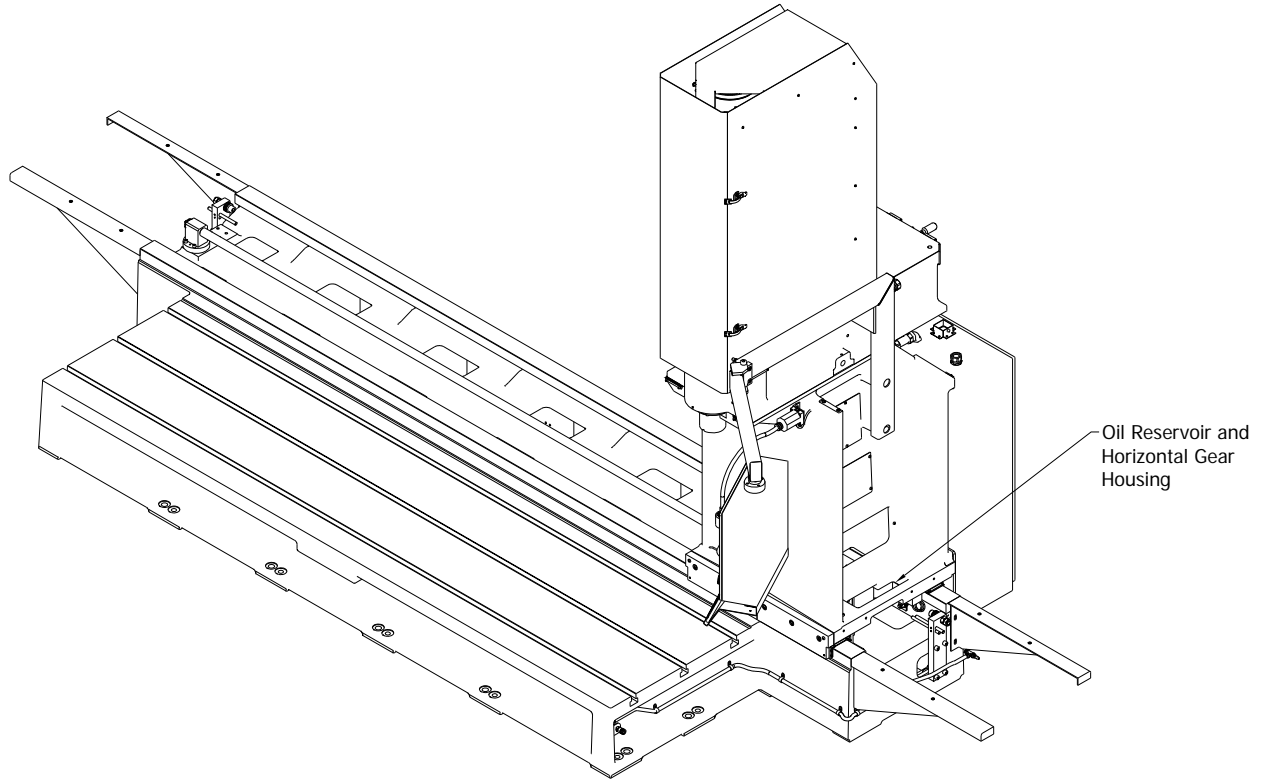

REF90Y47

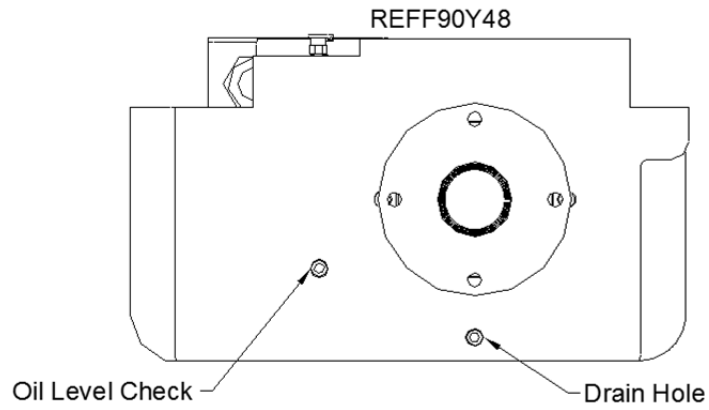

Oil Level Check

Drain Hole

Air Logic:

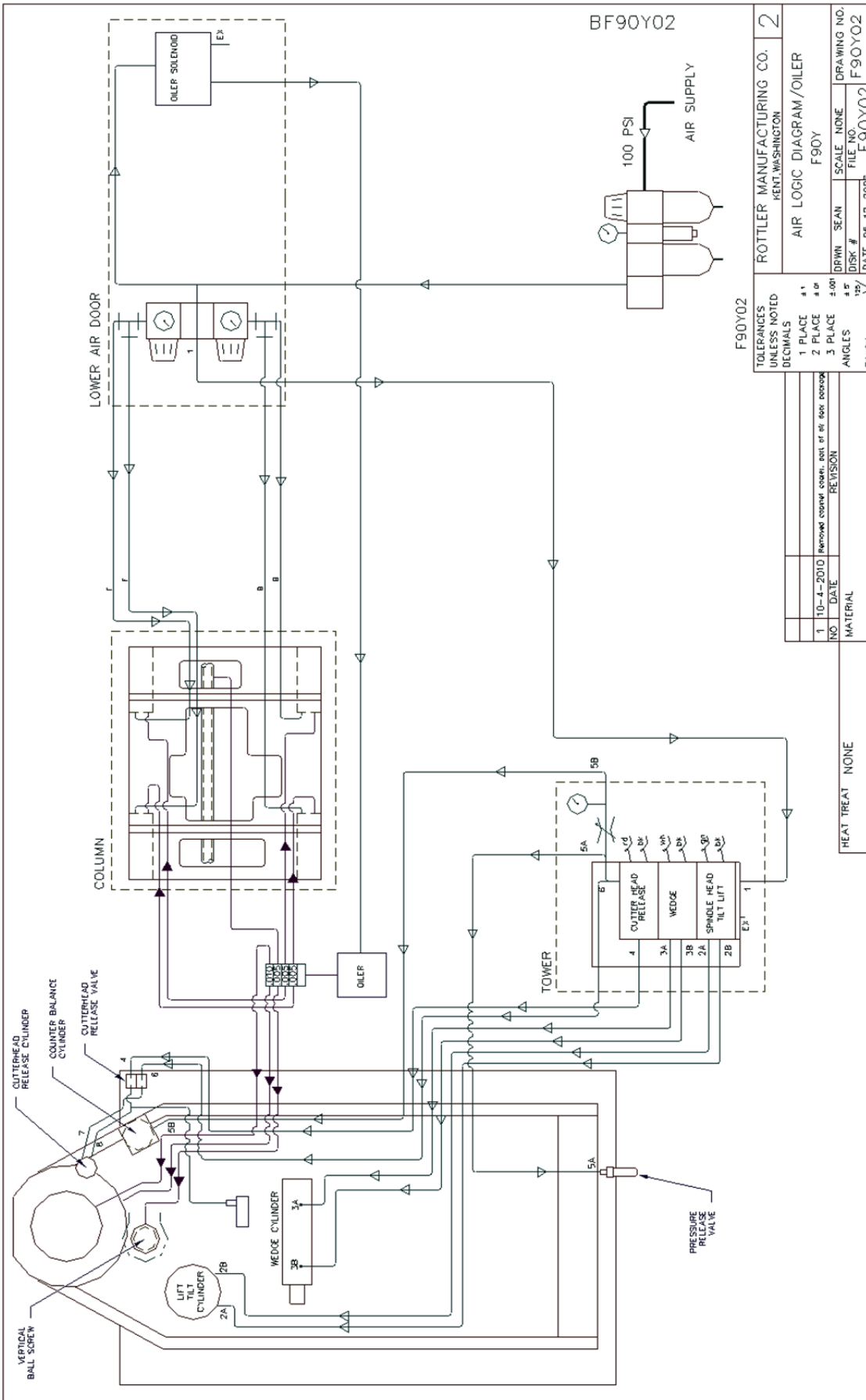

BF90Y02

F90Y02

ROTTLER MANUFACTURING CO. 2		KENT, WASHINGTON	
AIR LOGIC DIAGRAM/OILER			
DRWN	SEAN	SCALE	NONE
DISK #		FILE NO.	F90Y02
DATE	05-12-2008		
TOLERANCES UNLESS NOTED		1 PLACE ±.1	
DECIMALS		2 PLACE ±.01	
		3 PLACE ±.001	
ANGLES		±5°	
		±.2°	
FINISH		✓	

NO.	DATE	REVISION
1	10-4-2010	Removed copper cover, edit of air logic diagram

MATERIAL

HEAT TREAT NONE

F90M Wiring Diagram 9023E Radio Probe:

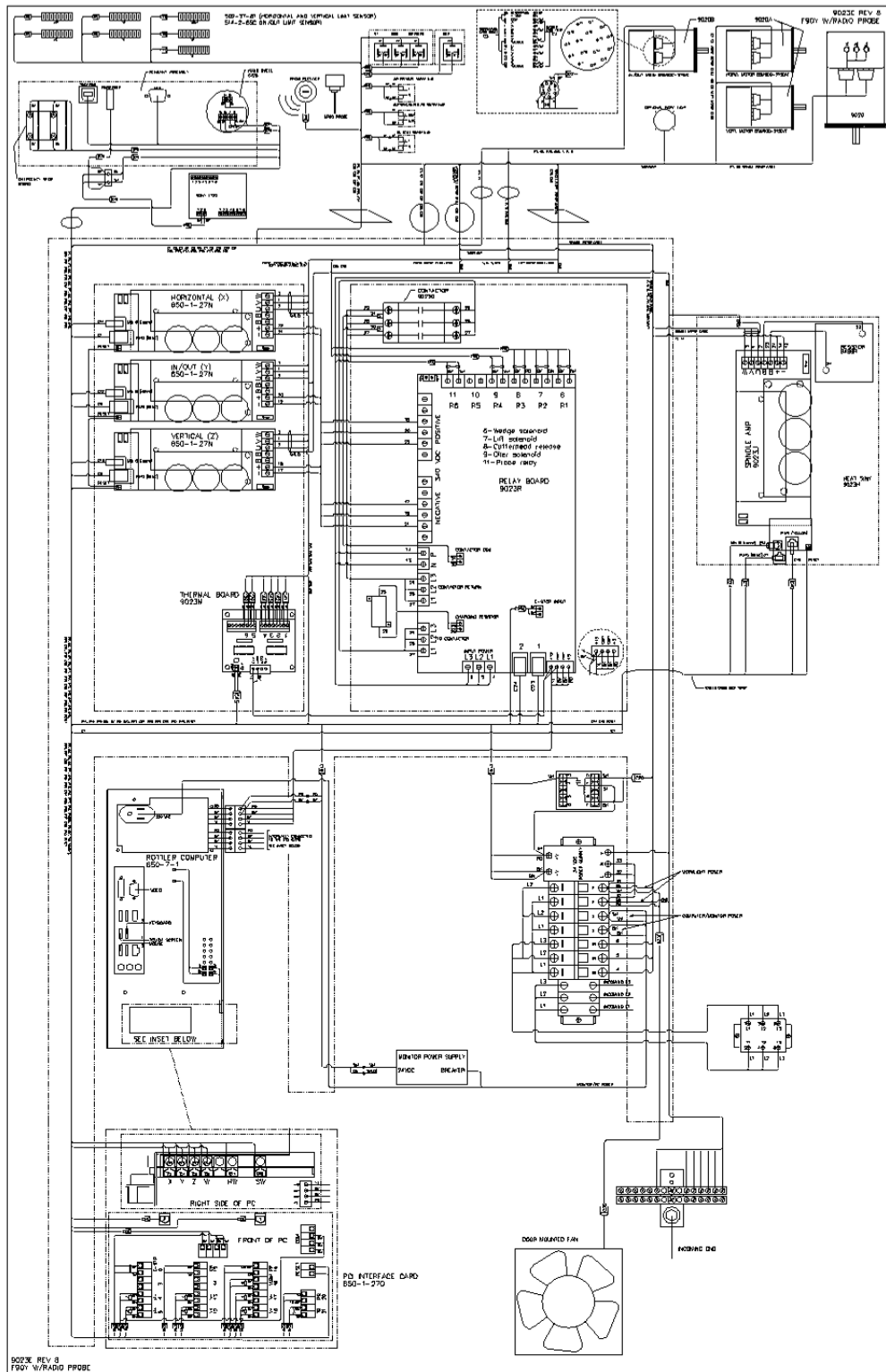

F90M Wiring Diagram 9023E Continued:

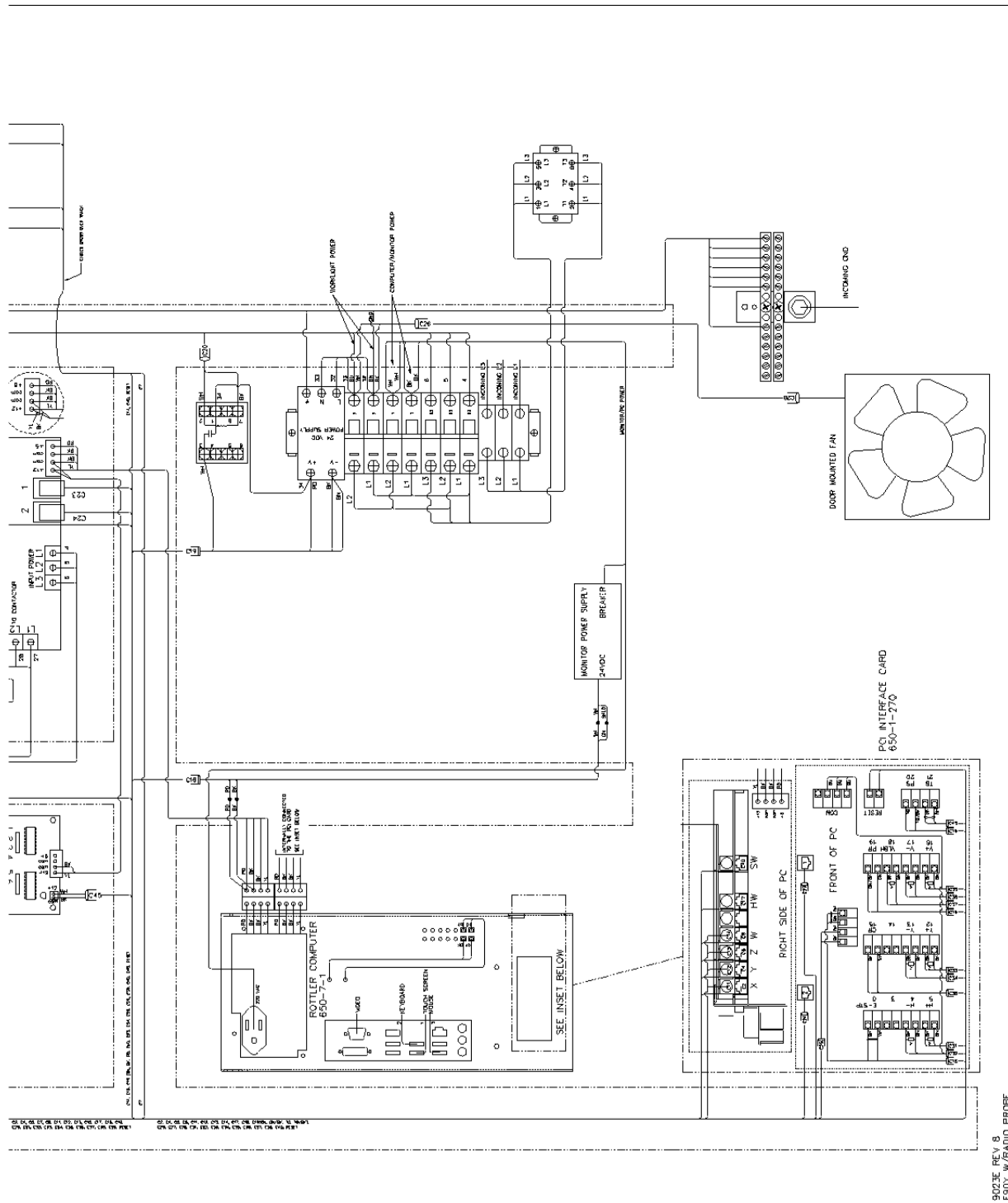

502-12-7B Sony LT20 Set Up Instructions:

A standard initialization is carried out at the time of shipment, however it is possible to make the following selections depending on the intended use. Details of the settings at the time of shipment are given in each section.

Changing between Inches and mm:

Turn on the power while holding down the "RESET A" button and press the "MODE" key/ Press the Up arrow to change between inches/mm. Press the "SET" button to set and return to the measuring state.

This device was set to mm st the time of shipment from Sony.

To change the initial settings... Press and hold the "SET" key and "MODE" key for approximately 2 seconds.

Basic Operation:

"MODE" – To the next item.

"UP ARROW" – Select the item.

"SET" – Set Item.

Note: *Even if you select and item with the "UP ARROW" key, no changes will be made until you press the "SET" key.*

Note: *Once the initial setting modes had been entered it is not possible to return to the measuring state partway through. Press the "MODE" key repeatedly to skip items.*

Basic Settings:

Setting the display (2 channel Models).

One of the following may be chosen: A and B or Only A+B.

A	disp
B	

Setting the input signal resolution (channel A)

One of 0.0005, 0.001, 0.005 or 0.01 mm can be chosen.

Set the resolution to match the resolution of the connected measuring probe.

	rSLP
A	0.0005P

Vertical Servo Drive Belt Replacement / Adjustment:

⚠ CAUTION

Turn off all power to machine before attempting to adjust or replace belt. Serious injury may result.

The Vertical servo drive belt is located on top of the Spindle Unit.

Remove the four screws holding the top cover down. Remove top cover.

Loosen the two bolts securing the motor mounting plate and the tensioning set screw. Slide the motor mounting plate to loosen. Replace belt is needed.

Adjust servo motor mounting plate, using the tensioning set screw so the belt will deflect 5/16" when a force of 2 to 4 pounds is applied midway between the pulleys.

Fully tighten the two bolts mounting the plate.

Replace the cover on the top plate.

REF F90Y49

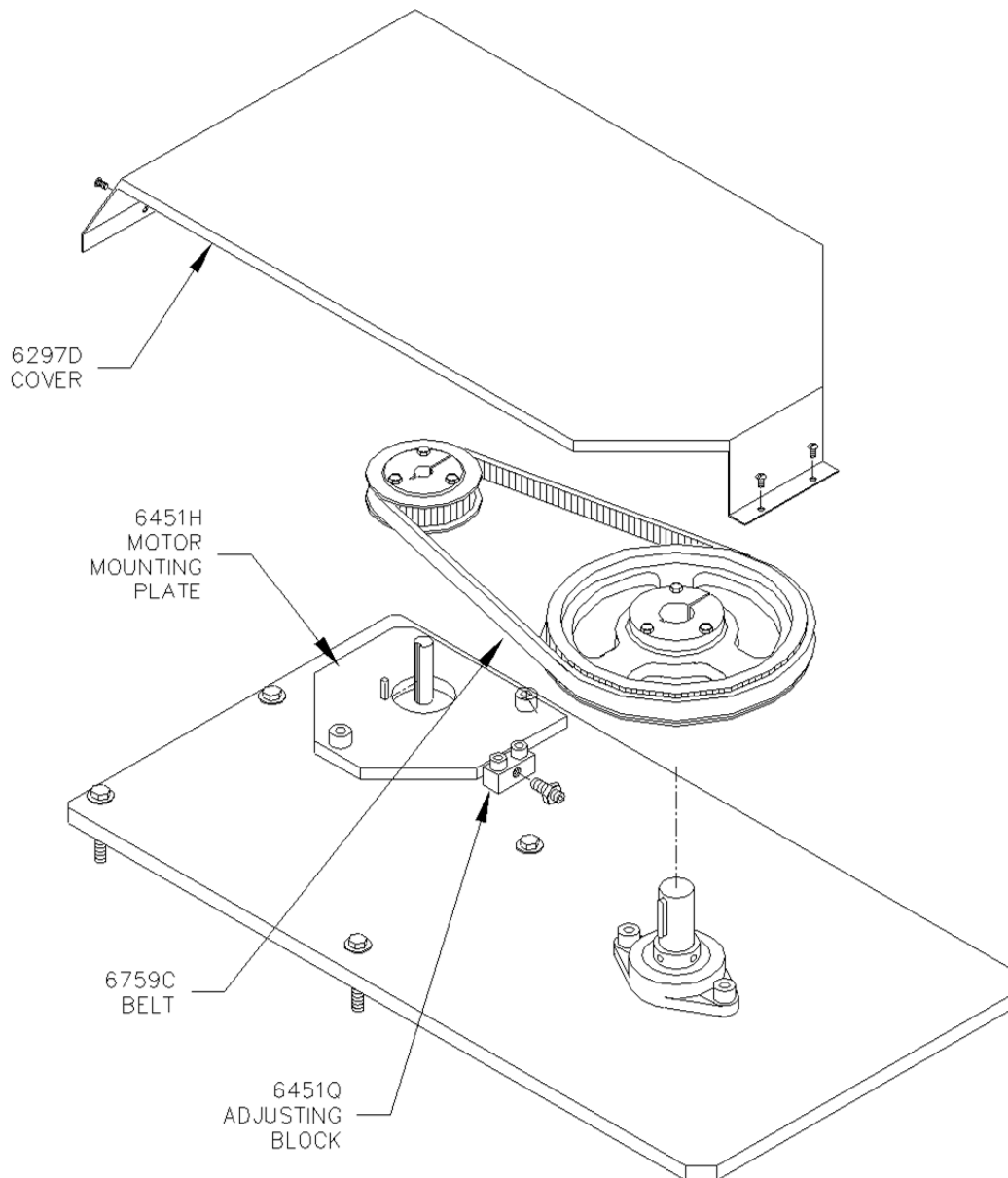

Outer Spindle Adjustment:

This adjustment should be made if you start to get taper in the lower portion of the bore or if the Spindle “Drops” when the power and air are turned off.

Open the main spindle base door.

Located where the outer spindle comes out of the spindle base, is the upper retainer ring (6224). Use a spanner wrench or modified punch to loosen the retainer. Lift the retainer out of the way and use a small screw driver to carefully lift the felt oiler (6250). Use a piece of tape or rag to secure the two pieces at the top of the outer spindle. Damage to the upper retainer threads will result if the outer spindle is moved and the retainer comes into contact with the spindle base.

Where the outer spindle comes out of the spindle base is the lower retainer(6247A). Remove the four (4) Allen head screws and slide the retainer off the spindle (the retainer will require cleaning before re-installing). Slide the two square wipers and the felt oiler off the spindle also.

Note: This is a good time to replace the Upper and Lower felt oilers if they are dirty. This will expose the lower adjustment nut, do not remove this.

Loosen the small Allen head set screw that lock the outer spindle adjustment nuts (6223). The set screws are located on the front of the lower bearing carrier (6225A), and on the front of the flanged sleeve (6221C),

Important: Loosen the set screw before you attempt to adjust the outer spindle nuts or damage to the threads may result.

Using a spanner wrench or modified punch tighten the upper and lower nuts equally until the outer spindle will no longer fall when the air and power are off. If the bores still have taper you may need to tighten the upper and lower nuts a little more.

To make sure the outer spindle adjustment is not too tight, place a .001” indicator on the bottom of the cutterhead to a flat surface. Place the machine in Vertical Handwheel mode at .001” per increment. Put about .005” pressure on the indicator. With every detent of the handwheel you should see a .001” movement on the indicator. If you have to move the handwheel several detents before the outer spindle move the desired distance the outer spindle adjustment may be too tight or there is not an adequate amount of oil on the spindle.

Re-assemble in the reverse order.

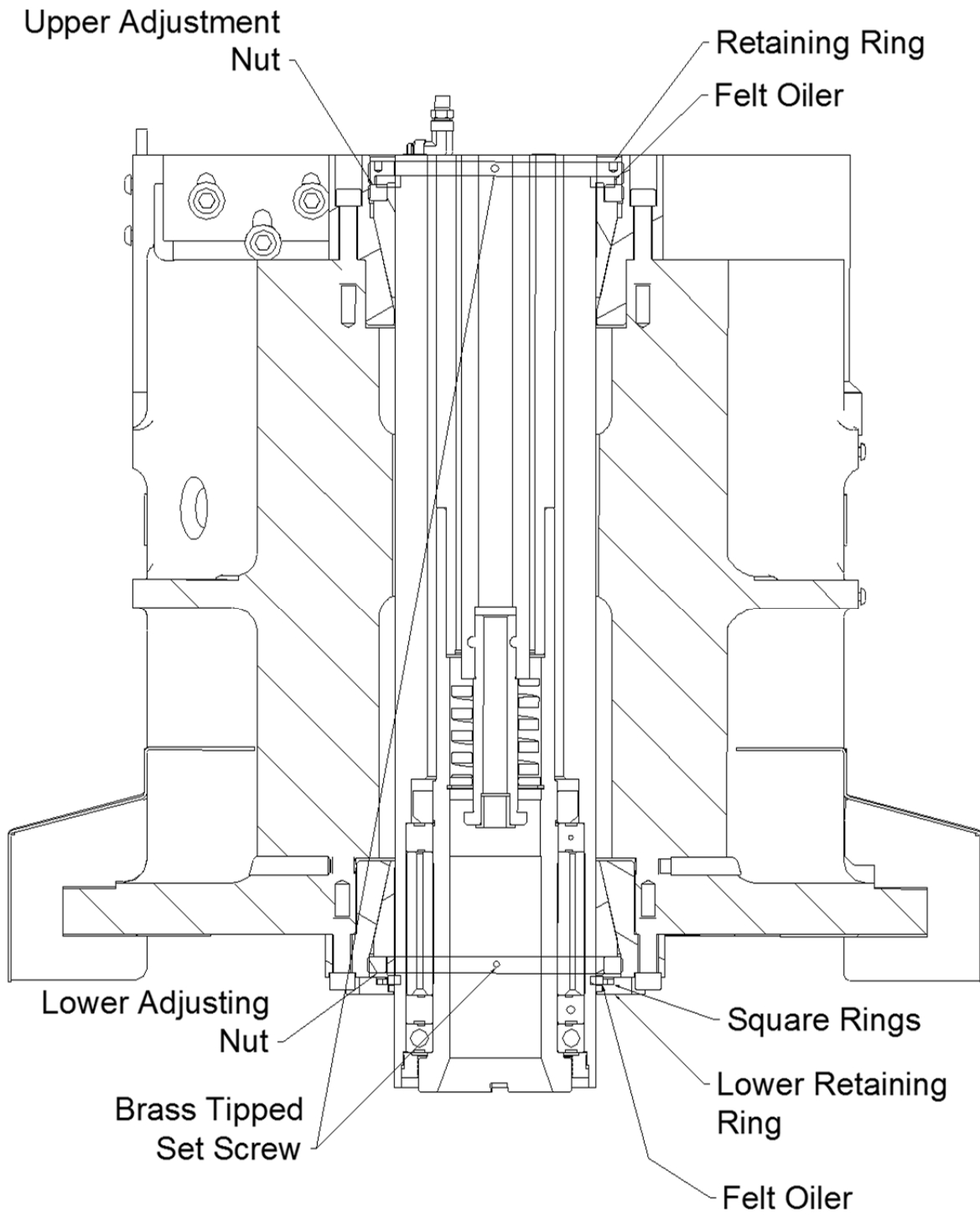

REF F90Y50

Inner Spindle Adjustment:

This adjustment should be made if you getting chatter or out of round bores.

Open the main spindle base door.

Install the surfacing cutterhead or a boring cutterhead with a long tool holder installed into the machine.

Locate the opening on the belt housing. This is located at the top of the outer spindle. Inside is the inner spindle adjustment nut (6091A). The adjustment nut has hole drilled in it along it's perimeter to allow for an adjustment rod.

Insert the adjustment rod into one of the holes in the adjustment nut.

Rotate the head 1 turn Clockwise looking from the top, letting the adjustment rod move up against the end of the slot in the belt housing. This will loosen the inner spindle adjustment.

Now carefully turn the cutterhead Counter Clockwise looking from the top. The cutterhead will turn easily and you should be able to feel the spring loaded ball detent in the nut. At some point the torque required to turn the cutterhead will sharply increase, immediately stop turning the cutterhead. This indicates that the Belleville washers have collapsed and the bearing is bottomed out.

IMPORTANT: DO NOT OVER TIGHTEN, SEVERE BEARING DAMAGE WILL OCCUR AND REPLACEMENT WILL BE NECESSARY.

Now turn the cutterhead Clockwise of detent.

Remove the adjustment rod, the inner spindle is now properly adjusted.

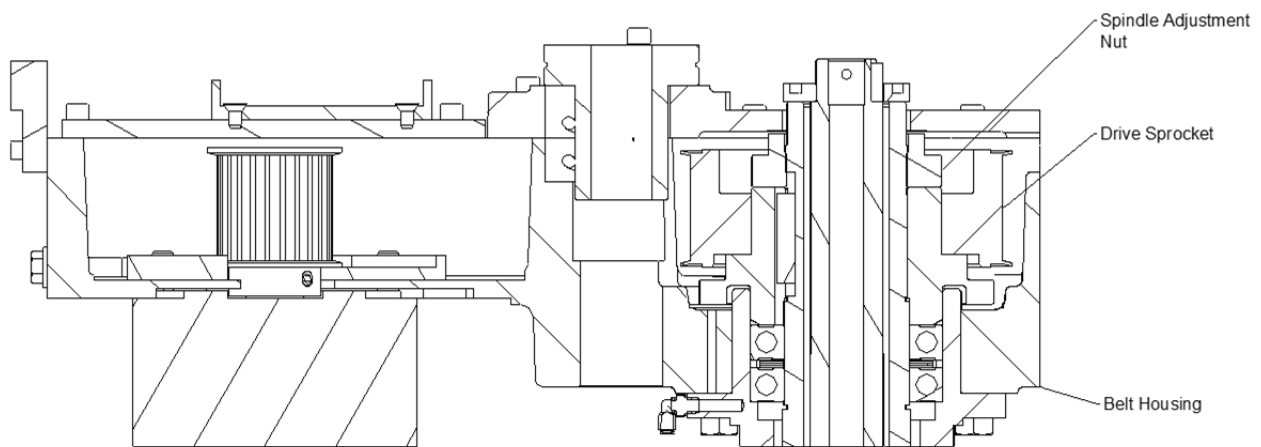

REF90Y51

F90M Upper Housing Disassembly:

Travel the machine to the right Home position.

Remove the spindle base door and right side cover.

Place a board across the spindle base directly below the spindle motor (6790K or 6790U). Lower the spindle until the motor just touches the board.



Disconnect all power and air to the machine before continuing, severe bodily injury may occur.

Remove the four (4) bolts securing the motor the belt housing. Remove the two (2) bolts that secure the cable carrier (6314K) to the upper housing. Remove the oil and air lines from the upper housing.

Note: It is not necessary to disconnect the spindle motor wiring.

Rotate the vertical ballscrew by hand until it is about eight (8) inches from the top plate.

Place a board, of proper length, between the bottom of the upper housing and the top of the spindle base to prevent it from falling.

Remove the two bolts that secure the centering gear housing (6168H) to the belt housing. Work the centering housing up off the centering shaft. Tie it up to the top plate.

IMPORTANT!!: Do not attempt to move the vertical under power when the centering housing is not bolted to the belt housing or the upper plate. Severe damage will result to the centering shaft!!

Remove the Clevis Pin (7210B) from the draw bar actuator bracket (6174B). Lift the actuator arm (6173B), move the arm and cylinder off to the side. Remove the air cylinder (6204A), clevis pin (6189A) and mount bracket (6188C) from the side of the belt housing. Remove the two (2) bolts that attach the draw bar actuator bracket (6174B) to the to belt housing cover.

Remove the counter weight cable (6453 F or 6453G) from the upper housing by loosening the lock nut and unscrewing the cable nut.

Note: When reassembling, be sure not to thread the cable nut in too far as it may come in contact with the driven pulley.

Remove the eight (8) screws holding the inner spindle end cap (6180A). Unscrew these bolts slowly around the diameter of the end cap as they are under spring pressure from the draw bar. Remove the cap by pulling straight up.

Note: When reinstalling, the end cap must be aligned concentric to the draw bar.

Remove the three (3) screws that secure the vertical ballscrew nut to the belt housing. Holding the nut with one hand, turn the ballscrew with the other to move it up and out of the way so the belt housing lid can be removed.

Remove the bolts securing the belt housing covers. The covers are pinned to the belt housing. Use a soft face mallet to carefully remove the covers.

From this position you can remove and/or replace pulleys and belts.

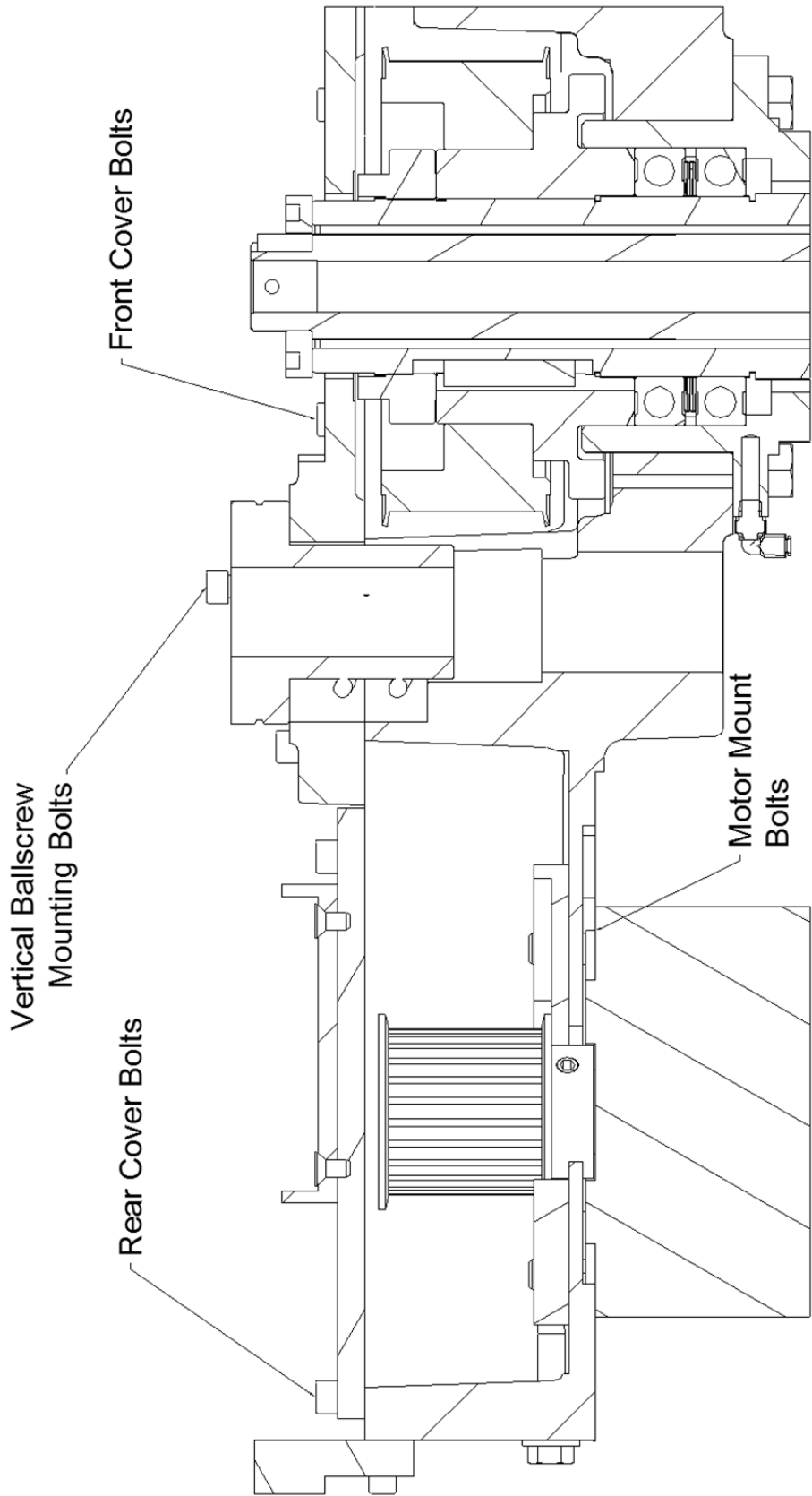

REF F90 Y52

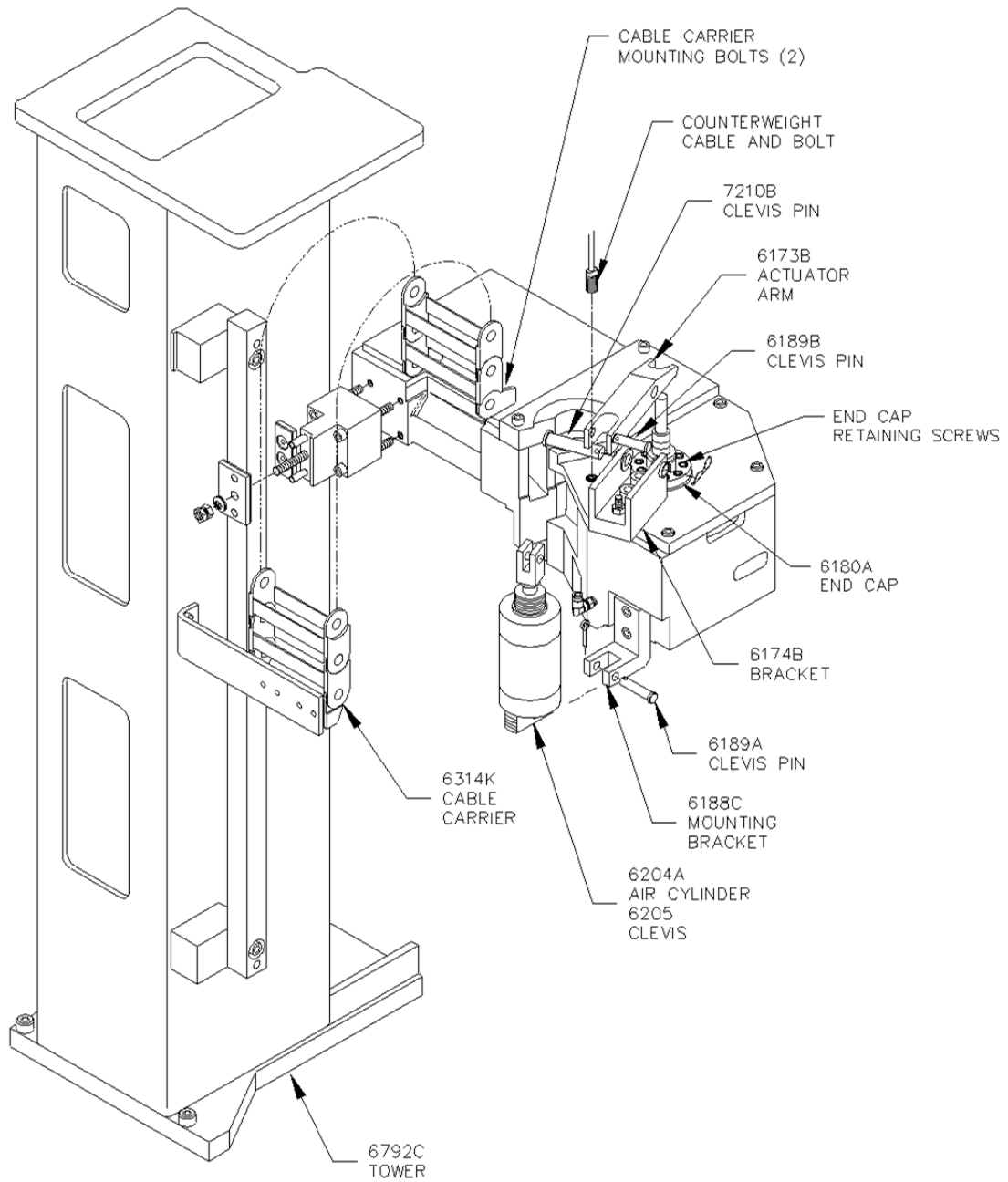

F90M Inner Spindle Removal:

Prior to following these instruction, perform the steps in Upper Housing Disassembly.

IMPORTANT: *When removing bearings, bellevilles and spacers, not the direction they come off for correct reassembly.*

The driven pulley and inner spindle adjustment nut must be in place before continuing. Remove the LEFT HAND THREAD throwback ring (6305D) from the bottom of the outer spindle.

Note: *If the driven pulley and inner spindle adjustment nut are not in place the inner spindle will be able to fall out of the outer spindle.*

While supporting the inner spindle from the bottom, remove the inner spindle adjustment nut and driven pulley from the top.

The inner spindle is now free to be removed from the bottom. This spindle is precision fit into the outer spindle, it may be necessary to tap the top of the inner spindle with a soft face mallet to get the spindle to drop out.

Note: *Be sure of the thrust direction of the bearings on reassembly.*

Reassemble in the reverse order.

Inner Spindle Angular Contact Bearing Replacement:

Prior to following these instruction, perform the steps in Upper Housing Disassembly and Inner Spindle Removal.

Loosen the three (3) Allen head set screws on the shoelock nut (6116F).

Loosen the shoelock nut and slide off of the top of the spindle.

Note: *Be very careful not to damage the threads when sliding nuts, bearings and sleeves off the top of the inner spindle. These are very fine threads used for the inner spindle adjustment nut.*

Remove the top bearing by tapping lightly and evenly on both sides of the bearing. After the bearing is moved slightly off of the spacer set (6172E) tap the inner race.

Note: *Tapping on the outer race can cause it to roll off of the bearings. Generally after removing the bearings from the inner spindle they are not suitable for re-use.*

Remove the spacer set.

Remove the two lower bearings (6116E) set of three (3) the same way as the top bearing.

Stand the spindle on end so that the bearing pack is nearest the floor.

Make sure inner spindle is free of all dirt and debris.

Lightly coat the lower bearing pack area with a light weight #10 oil.

If you have a bearing heater available to you, it is the preferred method of bearing installation. If not, follow the instructions below.

Slide the two (2) lower bearings onto the inner spindle with the correct bearing thrust direction until they stop. Use a small brass punch to lightly tap each side of the bearing on the inner race until both bearings are seated at the bottom of the spindle.

Install the spacer set.

Install the top bearing using the same procedure as the lower bearings until it is seated against the spacer set.

Install the shoelock nut and tighten with a spanner wrench until the inner races of the bearings and spacer set are fully seated together.

Tighten the three (3) set screws on the shoelock nut.

Place the inner spindle in a vise near the bearing pack and lock the vise. Indicate the bearing set to within .0005" all the way around. Adjust the spacer set by tapping the high side lightly with a brass drift.

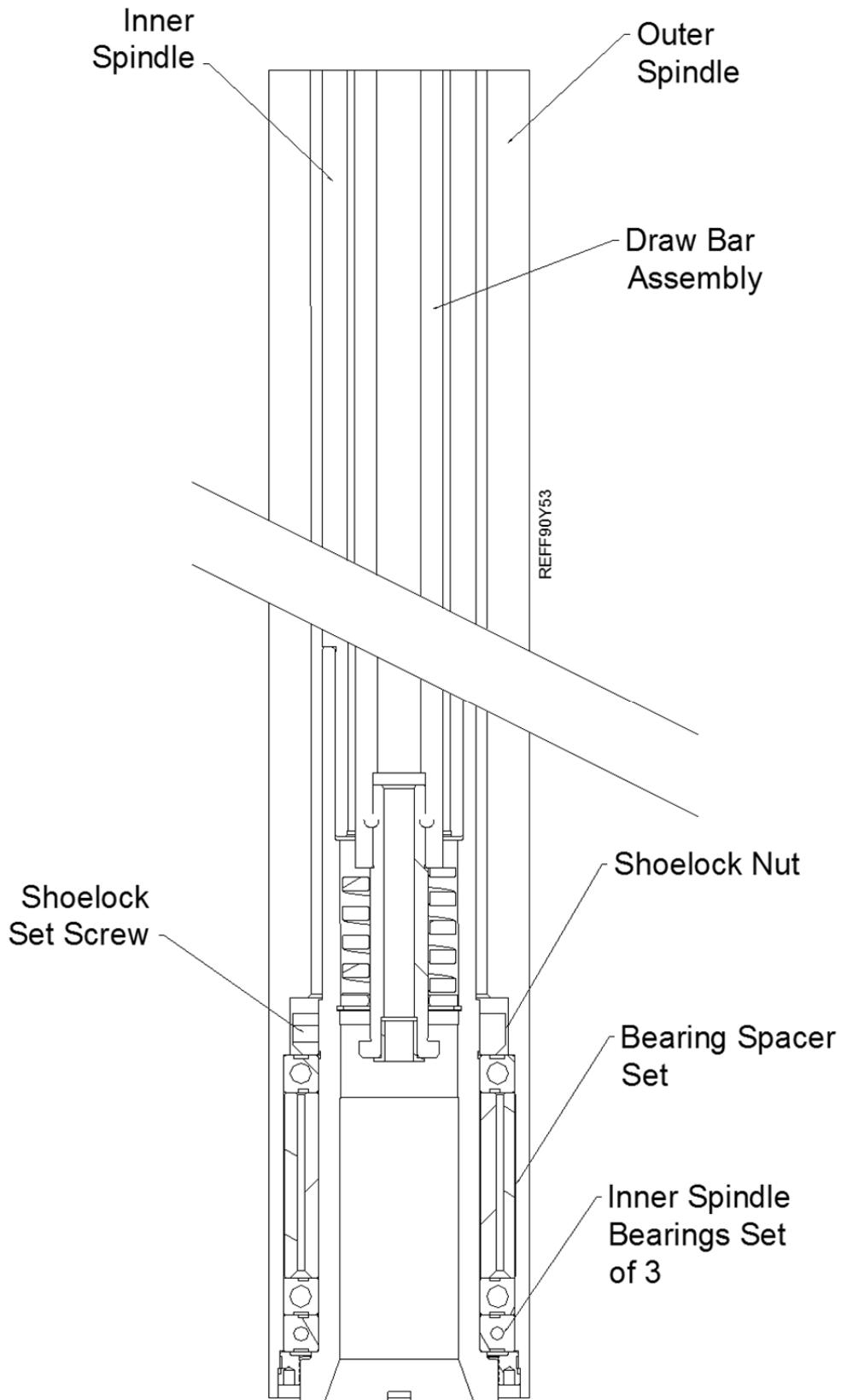

Spindle Sweep:

The outer spindle must be swept into the main bed of the machine to achieve accurate bores.

Remove all fixturing from the machine bed, clean and stone if needed.

Install a boring cutterhead into the machine.

Install the sweep are into the cutterhead.

Bring the machine down until you have about .005" pressure on the indicator.

CAUTION

Disconnect all power and air to the machine before continuing, severe bodily injury may occur.

Turn the sweep arm to the 9 O'clock position. Zero the indicator here.

Loosen the 6 socket head cap screws on the lower spindle hub. You do not want them all the way loose, just snug.

Use the three (3) set screws in the spindle base to move the spindle until the indicator reads within .0005" with a full 360 degree sweep of the indicator.

Note: You do not want the right hand side of the spindle to be more positive than the left, it will interfere with the automatic tilt of the machine when in Mill mode.

Once the spindle is swept in tighten the six (6) socket head cap screws and double check that the sweep did not move.

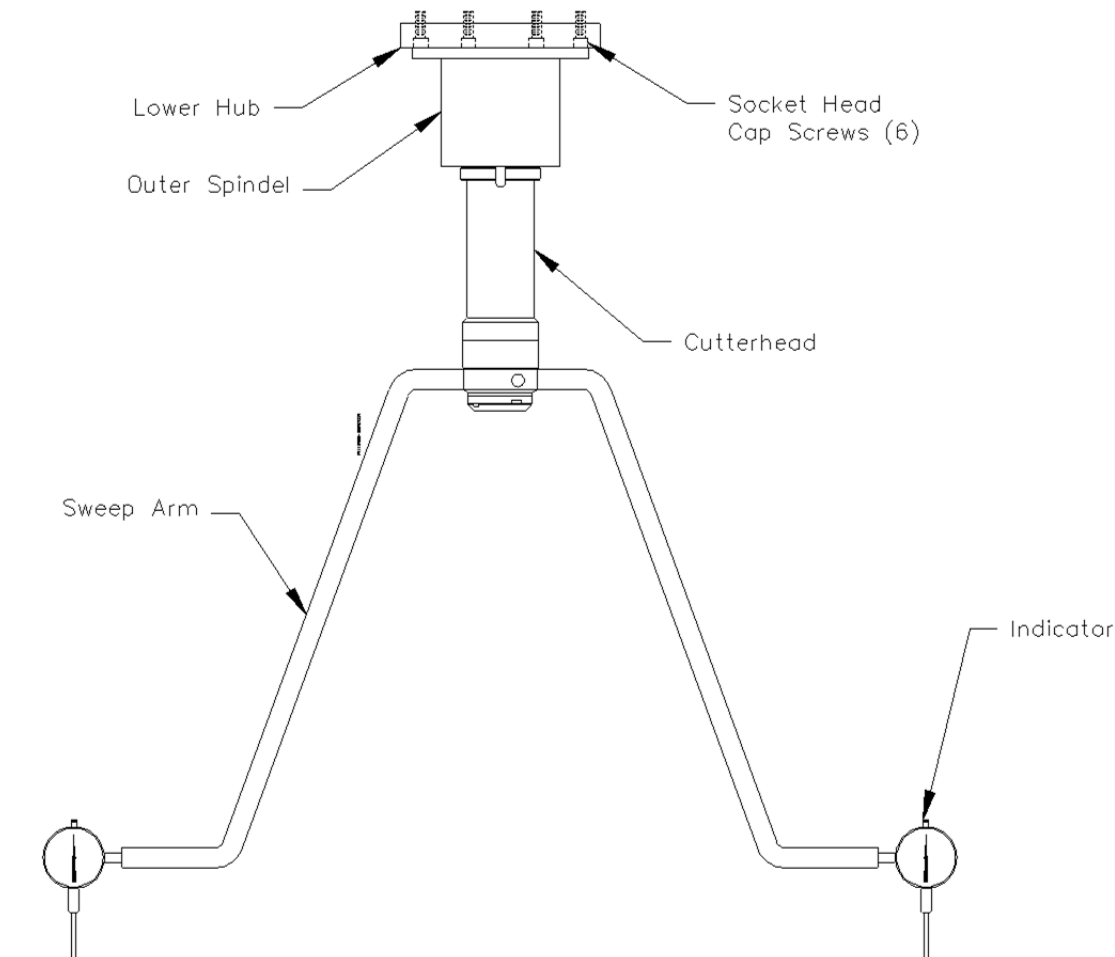

Horizontal Gibs:

The Horizontal gibs are located under the main column, on the back side of the front way. These gibs keep the column from “cocking” when the direction of travel is changed. This adjustment becomes more critical when line boring. If the gibs are too loose the column will turn slightly side ways when traveling. This will cause the alignment of the right angle drive to be off. The cutterhead will then cut heavier on one side of the bore.

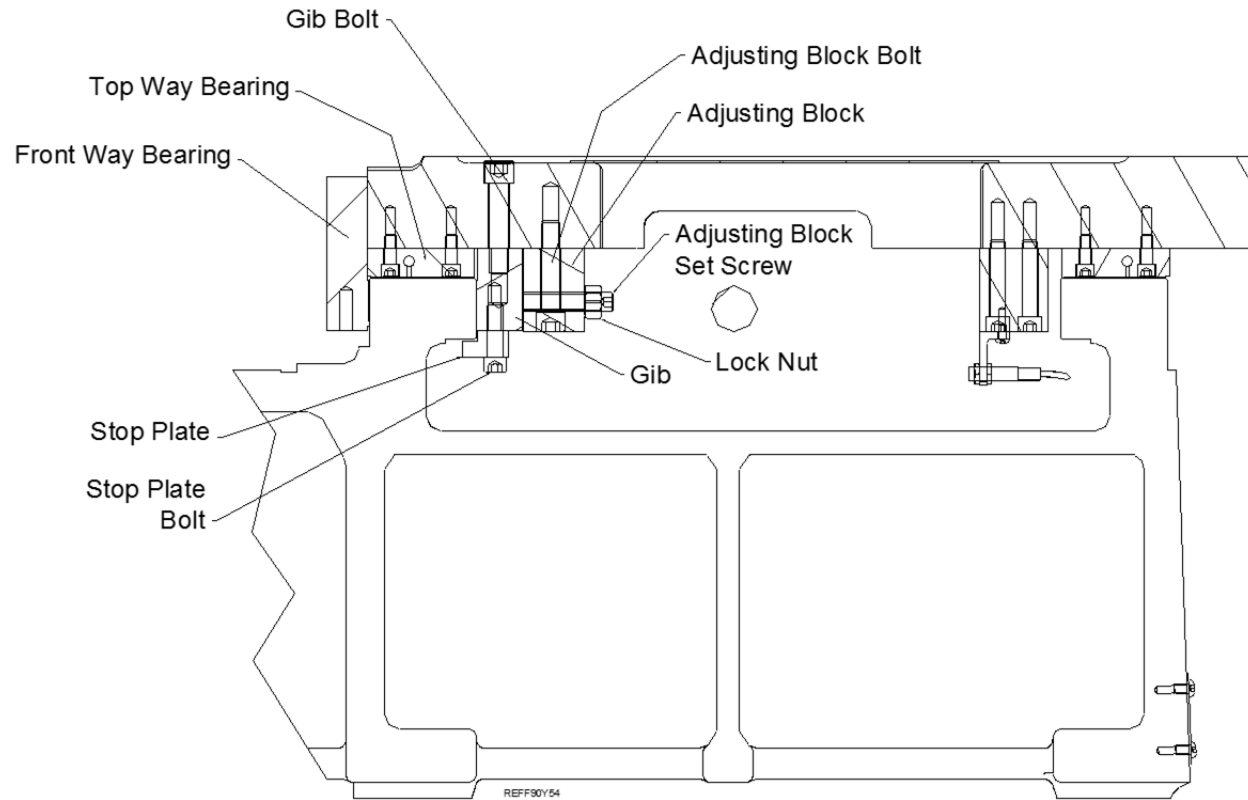

To adjust:

Loosen the Gib bolts (two on each side)

Loosen the Lock Nut on the set screw.

Tighten the set screw as much as possible using only the correct size Allen Wrench. This will pull the Front Way bearing up against the front way while pressing the Gib up against the back of the Front Way.

Loosen the Set Screw.

Tighten the set screw up until you can feel it contact the Gib.

Lock the Lock nut.

Run the machine back and forth to let the gibs adjust to adjust in.

Tighten the Gib bolts.

If the machine will not travel full speed or the handwheel movement is erratic the gibs may be too tight. Re-adjust leaving the Set Screw a little bit looser than the previous adjustment.

Another way to check for correct adjustment is to attach a magnetic base dial indicator (.0001 resolution) to the column with the indicator tip contacting the machine way surface.

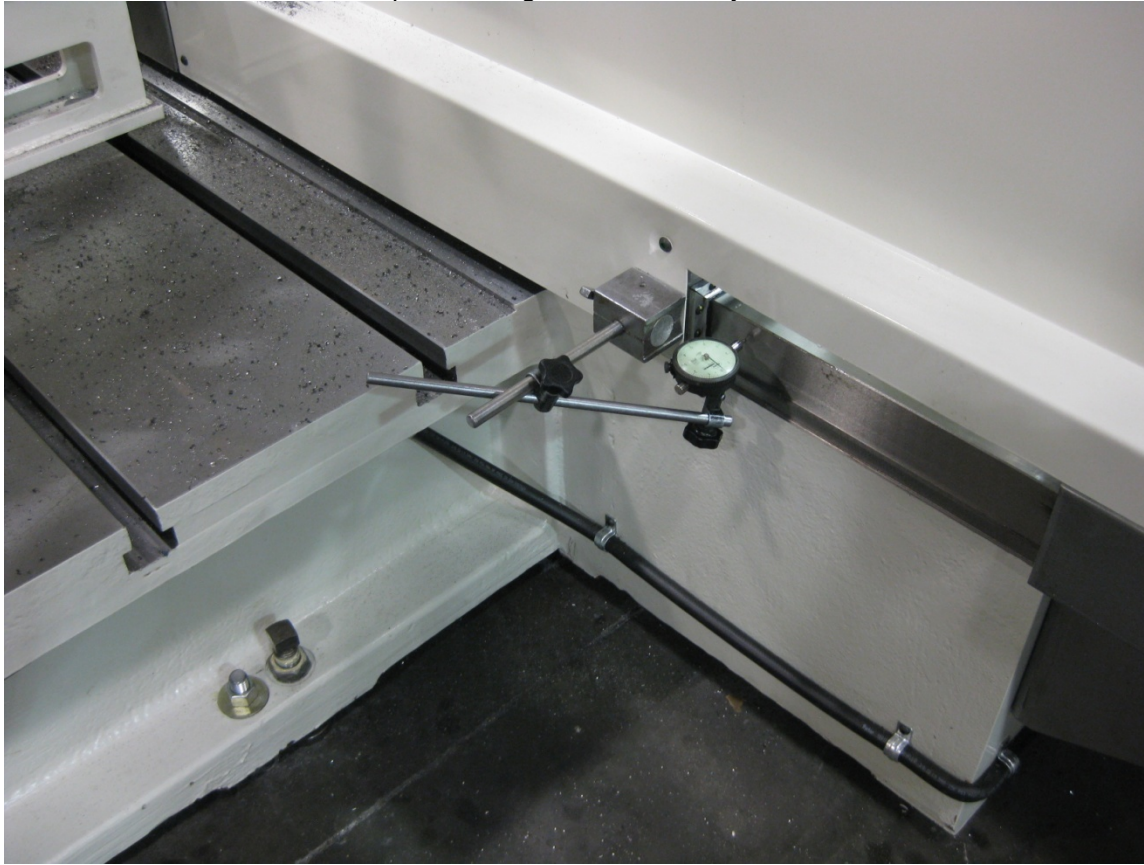

Now using the handwheel in .010" per click mode, move the column back and forth, about two turns on the handwheel in each direction at a rapid rate.

Note the amount of movement on the dial indicator.

The acceptable amount of movement on the dial indicator is between .0002"- .0005".

Adjust as necessary. This procedure must be performed at both, the right, and left, sides of the column.

AUTO MODE BACKLASH SETTING INSTRUCTIONS

Notes:

***The photos shown are demonstrating the X axis (horizontal) backlash adjustment. The Y and Z axis are adjusted following the same steps.

***The direction of machine travel to put the initial load on the dial indicator, are as follows:

X (horizontal), from the right toward the left.

Y (in/out), from back toward the front.

Z (vertical) from top toward the bottom.

***During the check, and adjustment of the Z axis, occasionally the touch screen may not respond. Simply press "Stop Machine", and continue on. This is normal, and caused by not moving the X or Y axis away from zero before pressing "Move to Zeros".

Attach a magnetic base, 1" travel dial indicator to a stationary stand, parallel, or engine block fixed to the machine bed.

Bring the spindle of the machine in position to put a slight load on the indicator. Adjust the indicator dial so the needle is on zero.



Set "Vertical, Horizontal, In/Out" zero.

ROTTLER CYLINDER BORE
ROUGHING THROUGH BORE

Feedrate Override 100% Vert 0.0000 In/Out 0.0000
Distance To Go 0.0000 Horiz 0.0000 Spindle 352

SET ZEROS VERTICAL STOPS LEFT LOCATIONS RIGHT LOCATIONS

Zero	Actual Position	Handwheel
VERTICAL	0.0000	.010 .001 .0001
HORIZONTAL	0.0000	.010 .001 .0001
IN/OUT	0.0000	.010 .001 .0001
SPINDLE	352	10x COARSE FINE

Spindle Load 0%
Feed Rate 0.0020
Spindle RPM 450.00

ALIGN SPINDLE
HOME MACHINE
MOVE TO ZEROS
CW INDEX CCW INDEX
START SPINDLE

STOP MACHINE

F90 SERIES OPERATOR CONTROLS ©2008 ROTTLER Manufacturing, Inc.

Set all vertical stops to "zero".

ROTTLER CYLINDER BORE
ROUGHING THROUGH BORE

Feedrate Override 100% Vert 0.0000 In/Out 0.0000
Distance To Go 0.0000 Horiz 0.0000 Spindle 352

VERTICAL STOPS SET ZEROS LEFT LOCATIONS RIGHT LOCATIONS

BORE PROFILE		PROBE OPTIONS	
Block Clearance	0.0000 SET	Probe Height	0.0000 SET
Centering Height	0.0000 SET	Probe Clearance	0.0000 SET
Start Boring Height	0.0000 SET		
Bottom of the Bore	0.0000 SET		

STOP MACHINE

F90 SERIES OPERATOR CONTROLS ©2008 ROTTLER Manufacturing, Inc.

Move the machine spindle away from the dial indicator a few inches, and press "Move to Zeros".



Repeat the movement to verify the machine will repeatedly position itself at zero. Now, use the handwheel to move the spindle in the opposite direction to nearly fully load the dial indicator.

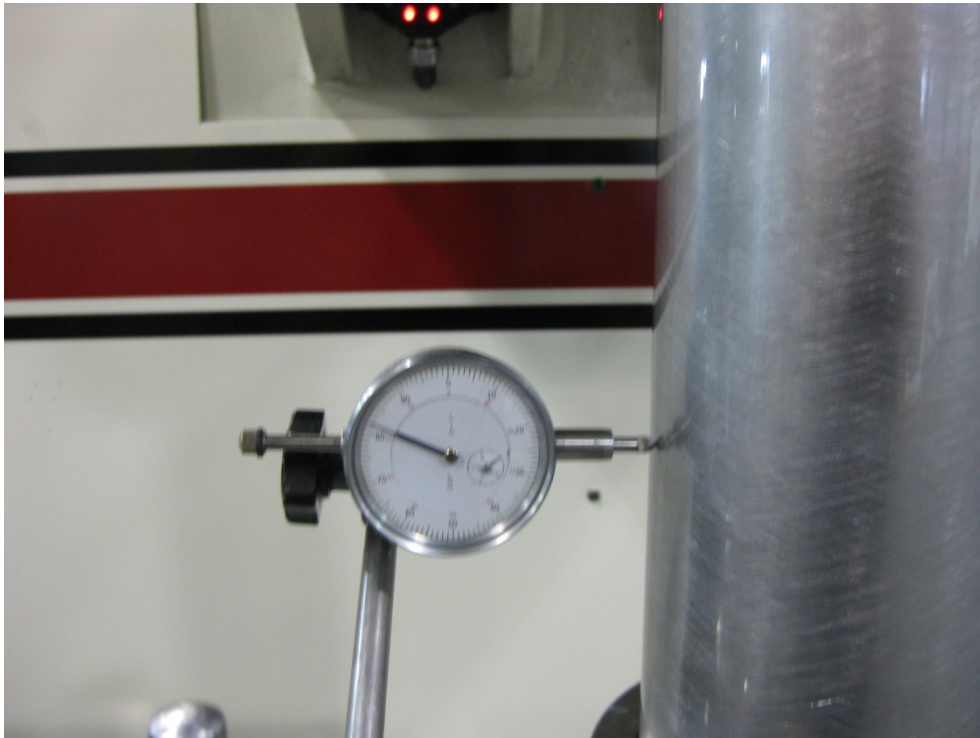

Press "Move to Zeros".



If the machine did not position itself to bring the dial indicator needle to zero, an adjustment is needed. To adjust, go to "Setup", then "General Options". Find the column labeled "Auto Mode Backlash" for the axis to be adjusted.

Axis Parameters				
Rapid	Accel Rate	Auto Mode BackLash	Handwheel backlash	Reverse Handwhee
100	4	0.0028	0.0042	<input type="checkbox"/>
80	4	0.0045	0.0055	<input type="checkbox"/>
80	4	0.0025	0.0028	<input type="checkbox"/>
80	8	0	0	<input type="checkbox"/>

Use the "On Screen Keyboard", or plug in the full size keyboard to enter the amount of correction. Example: If the amount noted in step #8 was .002", in the negative direction on the dial indicator, you would increase the existing amount by approx .001" (50% of the .002" error). If the number was in the positive direction, you would decrease the existing amount.

Repeat steps 5 through 8 and adjust as necessary until the machine positions itself to "Zero" on the dial indicator, from both directions.

HANDWHEEL BACKLASH SETTING INSTRUCTIONS

Note: The photos shown are demonstrating the X axis (horizontal) backlash adjustment. The Y and Z axis are adjusted following the same steps.

Attach a dial indicator to a stationary stand, parallel, or engine block fixed to the machine bed.

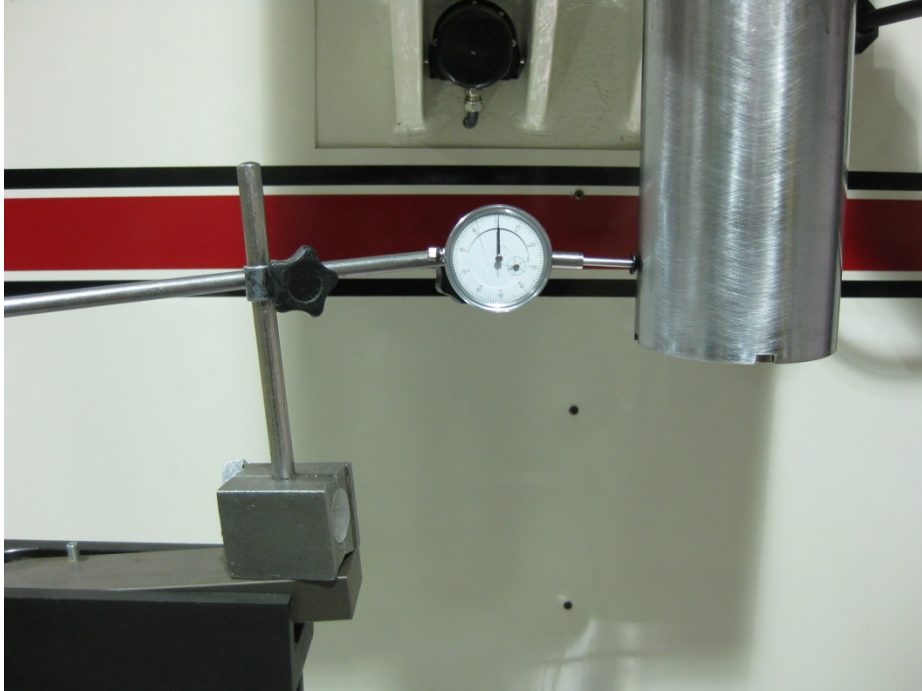

Bring the machine spindle in contact with the indicator.
Highlight the handwheel .001" per click button for the axis being checked.

Zero	Actual Position	Handwheel		
VERTICAL	12.7403	.010	.001	.0001
HORIZONTAL	67.9506	.010	.001	.0001
IN/OUT	-0.8323	.010	.001	.0001
SPINDLE	203	10x	COARSE	FINE

Activate the handwheel back and forth, one click at a time.



The movement shown on the indicator should be $.001$ ", plus or minus $.0002$ ". If not, an adjustment is needed.

To adjust, go to "Setup", then "General Options". Find the column labeled "Handwheel Backlash", and the box for the axis being adjusted. If the measurement found in step 4 is less than specified, increase the existing number in small amounts at a time until acceptable movement is shown. Use the "On Screen Keyboard", or plug in the full size keyboard to enter the amount of correction. If the measurement found in step 4 is more than specified, decrease the existing number.

Spindle Belt Adjustment:

The spindle belt should not require adjustment very often, but if required use the following instructions.

Open the Spindle Base shroud.

Loosen the four Motor mounting bolts on the spindle motor.

Tighten or loosen the Tension adjustment bolt on the rear of the belt housing until 5 pounds of pressure causes the spindle belt to deflect $\frac{1}{4}$ ".

If the spindle motor is run at high speed and a high pitched wining is heard from the belt housing area the belt adjustment is probably too tight.

If you can visually see the belt jumping around while running the belt is too loose.

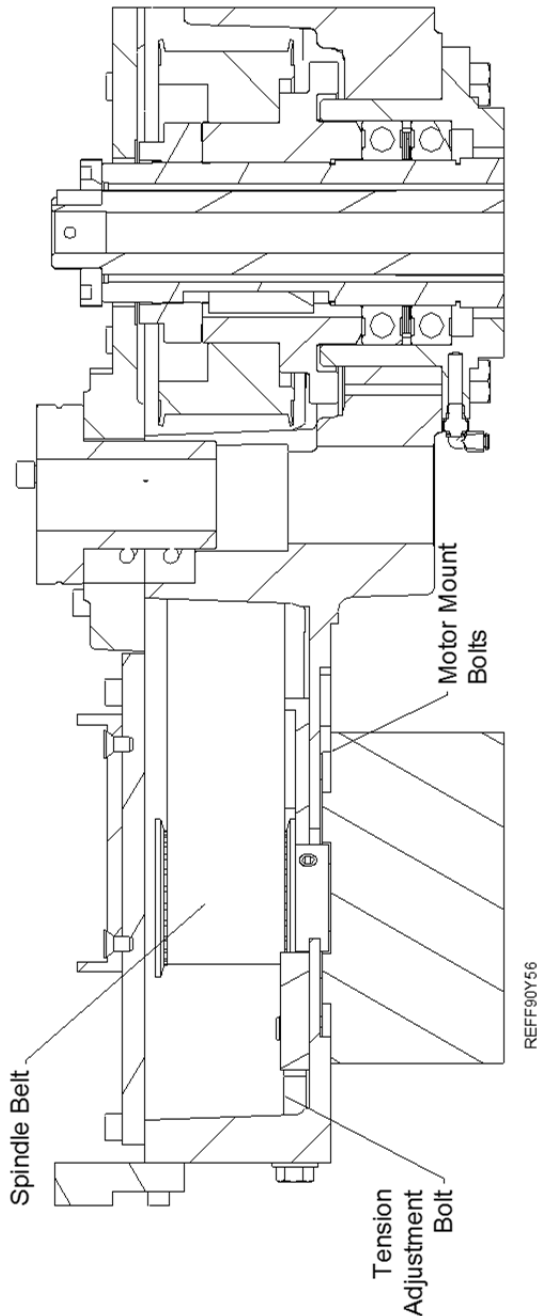

Preventative Maintenance Quick Reference Chart:

Refer to the procedures above to make or check these adjustments. Not all of the items listed in the table below have adjustment. The information should be recorded and the amount of wear tracked so the part can be replaced before down time on the machine occurs.

Procedure	Frequency
Inner Spindle	1000 Hours
Outer Spindle	500 Hours
Horizontal Gibs	2000 Hours
Vertical Belt	1000 Hours
Spindle Belt	1000 Hours
Spindle Sweep	150 Hours
Horizontal Ballscrew	2000 Hours
Horizontal Backlash	1000 Hours
Vertical Backlash	1000 Hours
In/Out Backlash	1000 Hours
Spindle Tilt	500 Hours
Machine Level	1000 Hours
Spindle Wear	2000 Hours
Horizontal Way Wear	2000 Hours

Digital Micrometer setting instructions:

Turn the thimble until the '0' line on the thimble lines up with the vertical line nearest the spindle lock ring.



Determine which cutter head bore range the micrometer is going to be used on. (example; 2.9 – 6.0)
We want to initially set the micrometer to the minimum bore diameter of this cutterhead.

NOTE: MICROMETER CAN NOT BE PROGRAMMED IF THE LETTERS INC APPEAR IN THE DISPLAY. To get rid of INC, quickly press the in/mm/ABS button.

To set or edit micrometer-

Press and hold the set/on button and the + or – button at the same time. “Set” will flash in the display. This places the micrometer in edit mode. (CAUTION: use a pencil tip or something similar to gently push the small round buttons - they are quite small and a bit delicate.)

Press and hold the + or – buttons to change the display number to the minimum bore diameter determined earlier (example; 2.9).

After you have reached the desired number in the display, press the set/on button twice quickly to exit the edit mode. “Set” should no longer be flashing in the display. The micrometer is now ready for set-up. (After initial setting, there is no need to press the set button again unless display is lost at which time the micrometer must be reset)

Micrometer is calibrated in inch mode. If metric is desired, press and hold in/mm/ABS button until mode changes to metric (approximately 3-4 seconds). A quick press of the in/mm/ABS button will put micrometer in ABS mode: 0.000, with another quick press returning it to initial setting.

Set up the cutter head and bore a set up hole. Measure the bore accurately. Set the digital display to this bore dimension and then -

Loosen the set screw holding the large diameter anvil. Slide the anvil back out of the way.



Place the tool holder used to bore the hole into the micrometer frame. Slide the location nub on the back of the tool holder gently up against the end of the digital micrometer shaft.



Slide the large diameter anvil up until it touches the end of the cutting tip of the tool holder. Tighten the set screw.





Back the digital micrometer shaft off, then bring it up to touch the tool holder and recheck that the numbers in the display are the same as the numbers previously shown.



The micrometer is now set up for use with this cutter head.

Note: this procedure must be repeated to set the micrometer to a different cutter head. The micrometer can only be set to one cutter head at a time.

To shut off micrometer press and hold set/on button until screen goes blank or let micrometer set until display disappears.

With initial setting of micrometer it is recommended that you use the procedure detailed below in the event you think you have size problems.

**Procedure:**

The short vertical lines that cross the horizontal scale on the micrometer sleeve are reference marks. Set the zero on the micrometer thimble even with the first vertical line and note the size shown in the digital display. Record this size for future reference. Now follow the same procedure for each line and record the sizes. At any time you feel your micrometer is reading incorrectly, you can quickly refer to the recorded size of the line closest to the range you are using and check that the micrometer is still accurate.

Probe “On-Center” Adjustment:

The optional shank adapter assembly allows the OMP40 to be mounted on shanks suitable for the MP10, MP12 and MP700 Probes.

Step 1 - Adapter Assembly:

Assemble the 650-3-59H adapter plate as shown. Fully tighten screw A to 0.68 lbf (3.0 Nm)

Step 2 – Probe / shank Mounting:

Fully loosen all screws and fit shank adapter to shank as shown on the following page. Tighten screw B to 1.35 lbf (6 Nm)

Fully tighten tighten screw C to 0.49 lbf (2.2 Nm)

Fit Probe / Shank assembly into machine spindle.

Step 3 – Adjustment:

There are four screws D. Each will move the probe relative to the shank in the X or Y direction as pressure is applied. Tighten screw individually, backing off after each movement.

Use screws D in opposition at the same time to move the probe, progressively tightening then as the final setting is approached. Use two Allen keys if needed. Tip run out should be .002” (5 Microns) should be achievable.

It is important that all four screws (D) are tightened to 0.49 lbf (2.2 Nm) once the final setting has been achieved.

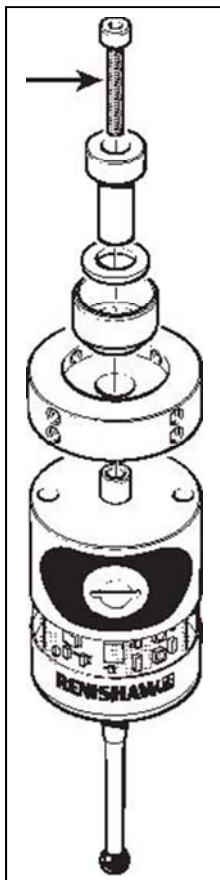

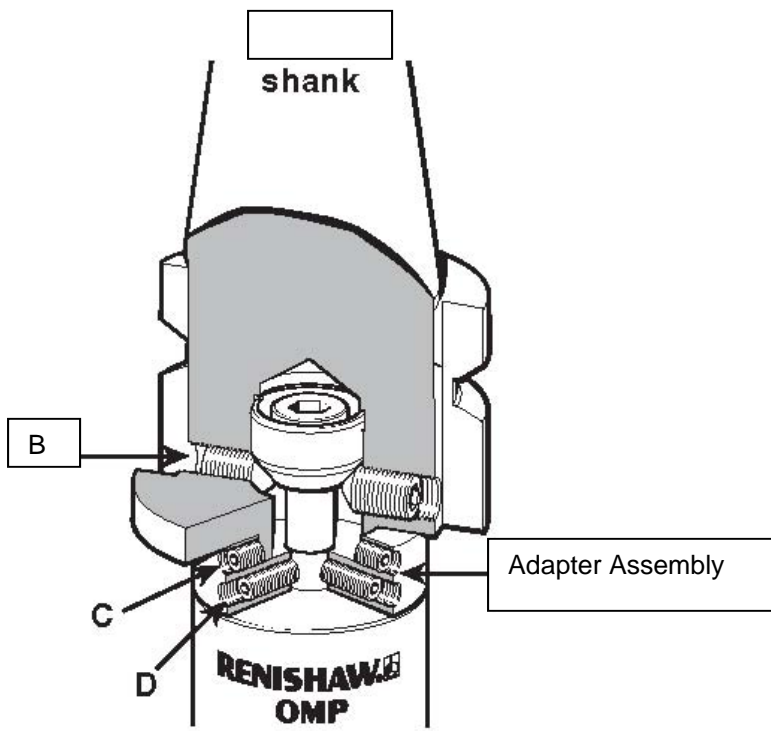

Troubleshooting

Chapter 6 Contents

Machine Parts:	2
F90M Front View:	2
F90M Left Side View:	3
F90M Right Side View:.....	4
F90M Rear View:	5
Air Control Door:.....	6
Air Control Tower:	7
Electrical Enclosure F90M Series:	8
650-1-27X Computer Enclosure Assembly:	9
650-7-1 Computer Components:	10
Spindle Base, Right Side:	11
Spindle Base, Left Side:	12
Spindle Base:	13
Rear Spindle Base:	14
Tilt Lift Cylinder:	15
Tilt Cylinder:	16
Vertical Ballscrew Assembly:	17
Vertical Ballscrew Bumper Package:.....	18
Lower Spindle:	19
Draw Bar / Centering Assembly:	20
Y-Axis Assembly:.....	21
Y-Axis Ballscrew Drive:	22
Top Plate Assembly:.....	23
Upper Housing tower Guide:	24
Upper Housing:	25
Pendant Swing Arm:.....	26
Pendant Assembly:.....	27
Way Cover Assembly:	27
Column Drive Assembly:	29
Horizontal End Stop Bumper Package:	30
Column Drive Gear Housing:.....	31
6580W Chip Shield Assembly:.....	32

**Machine Parts:
F90M Front View:**

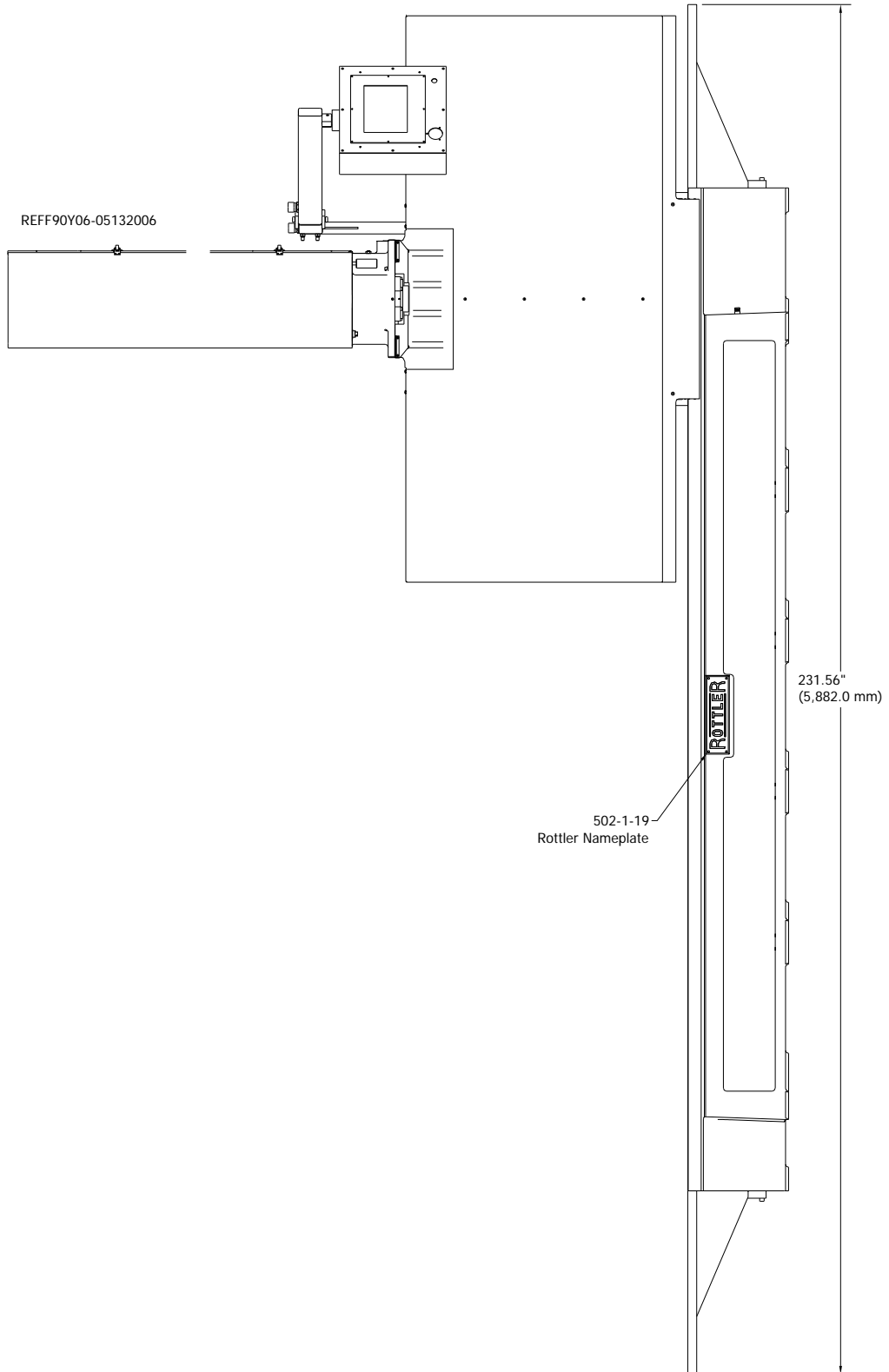

F90M Left Side View:

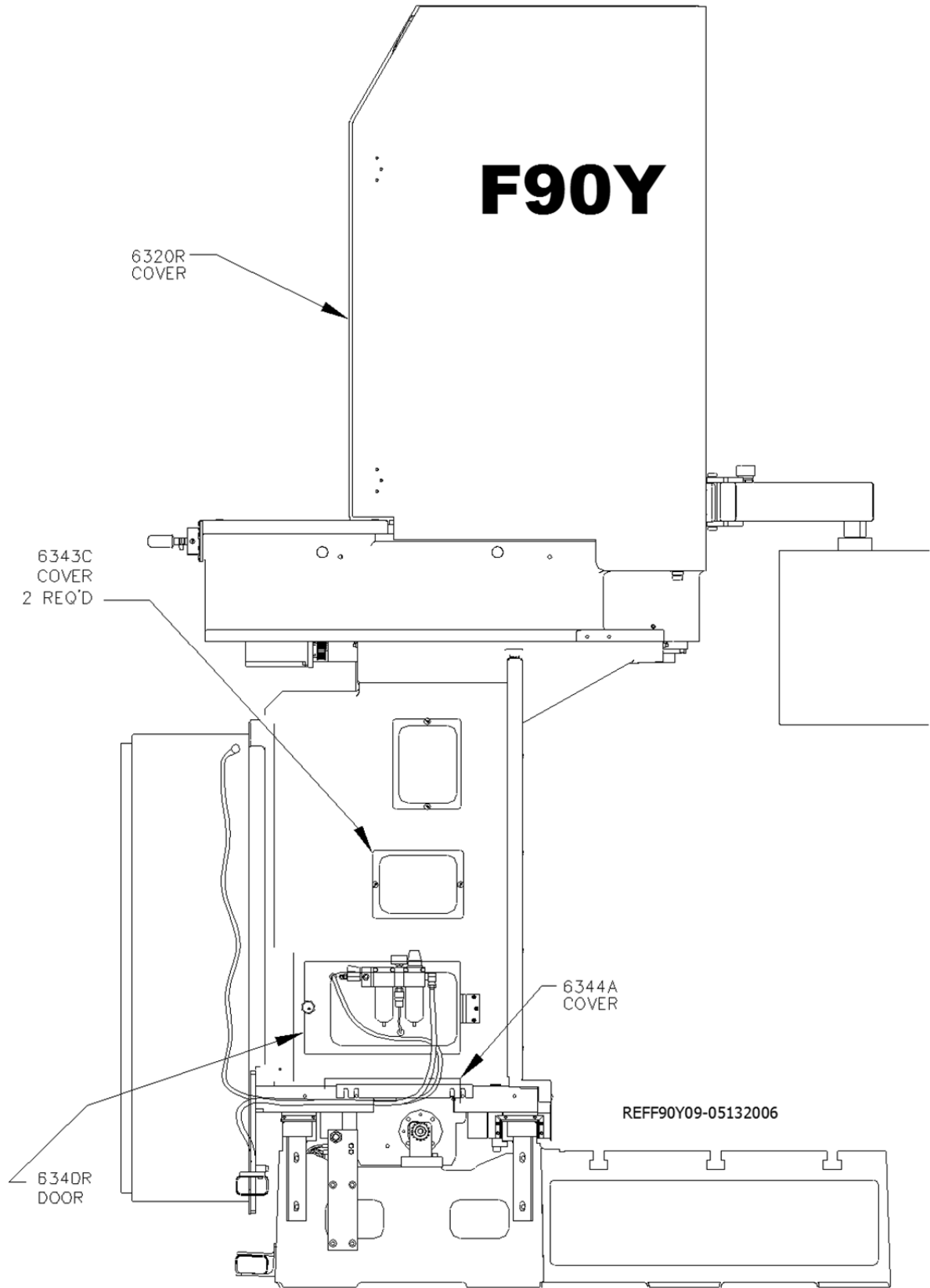

F90M Right Side View:

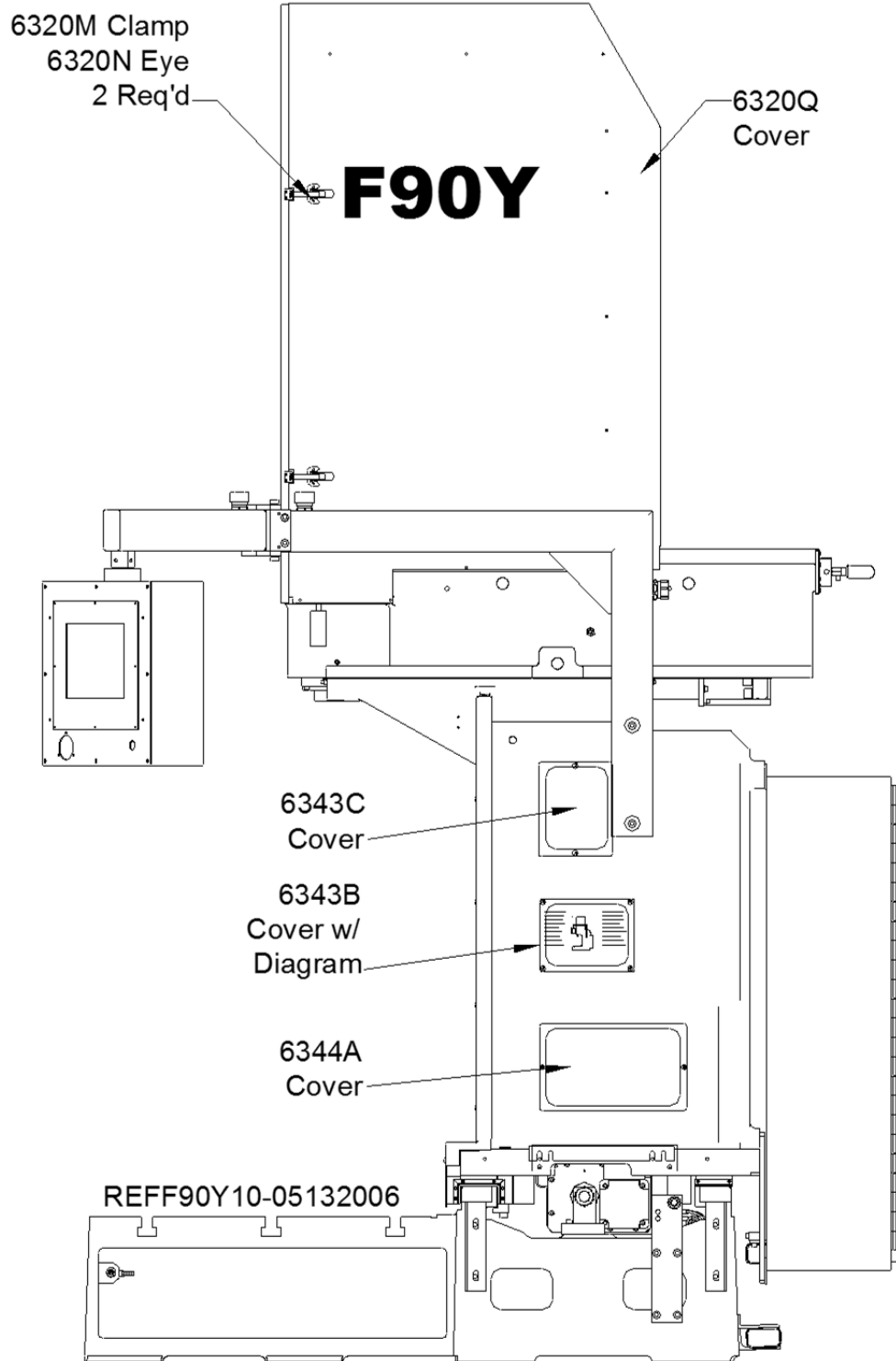

F90M Rear View:

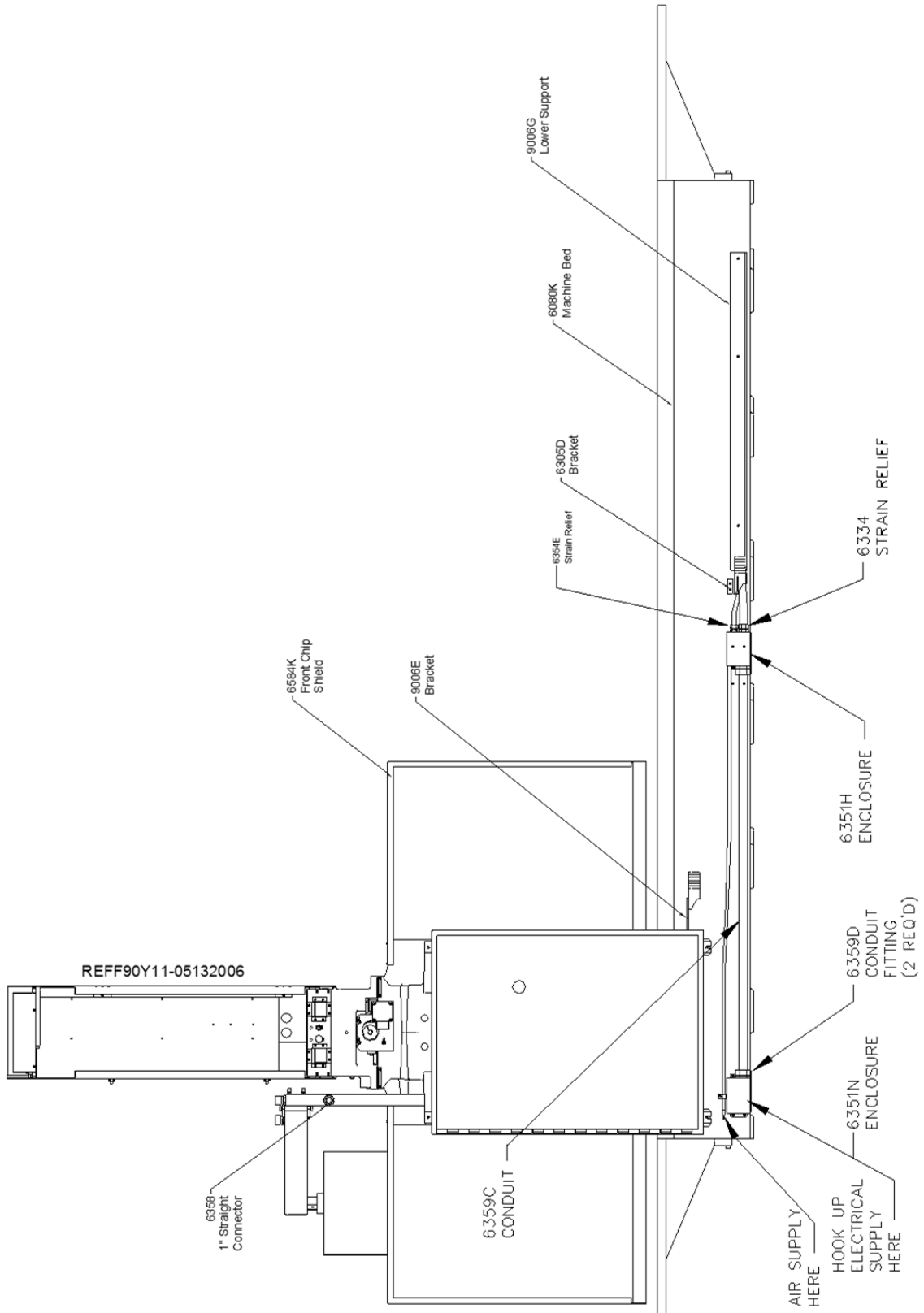

Air Control Door:

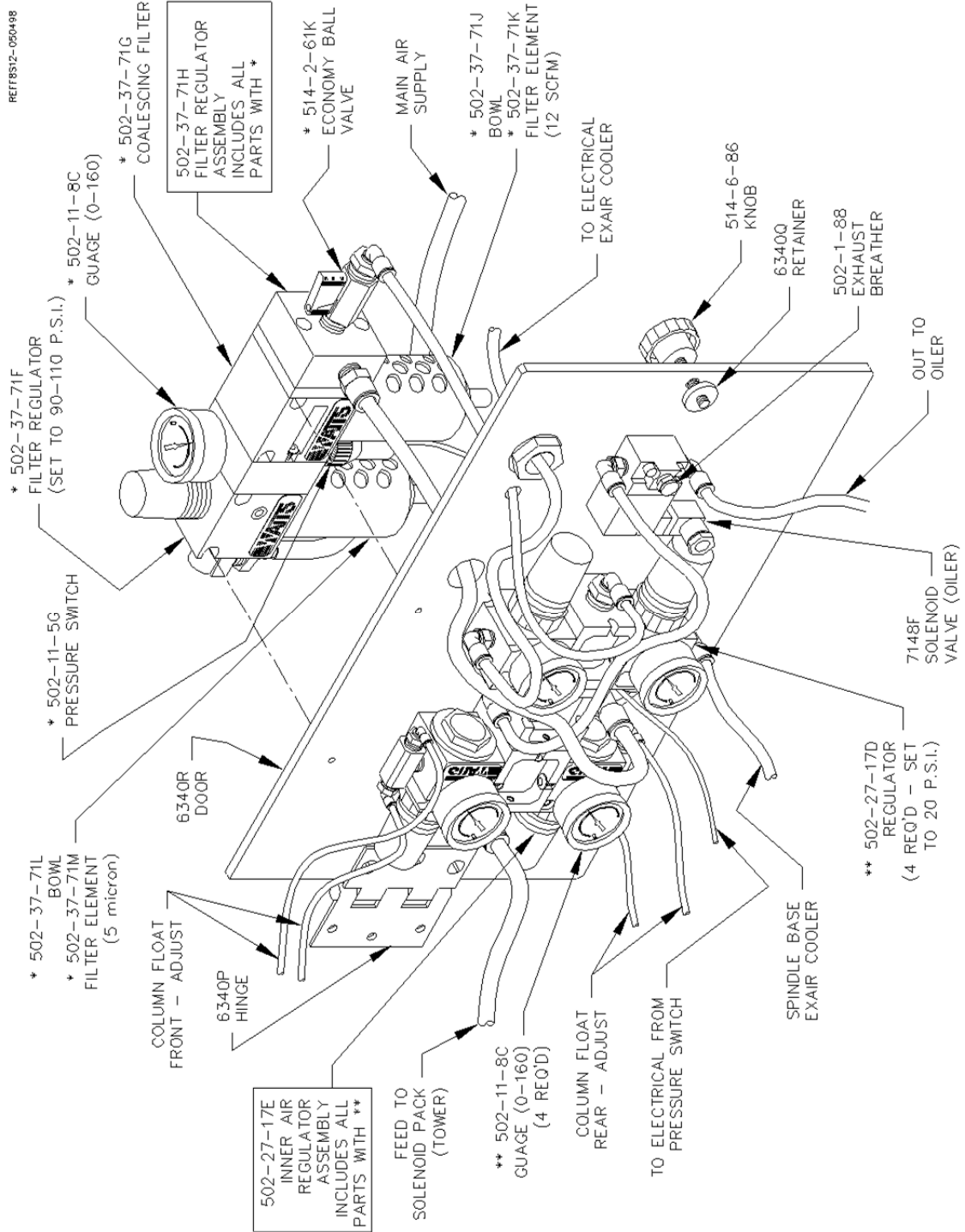

Air Control Tower:

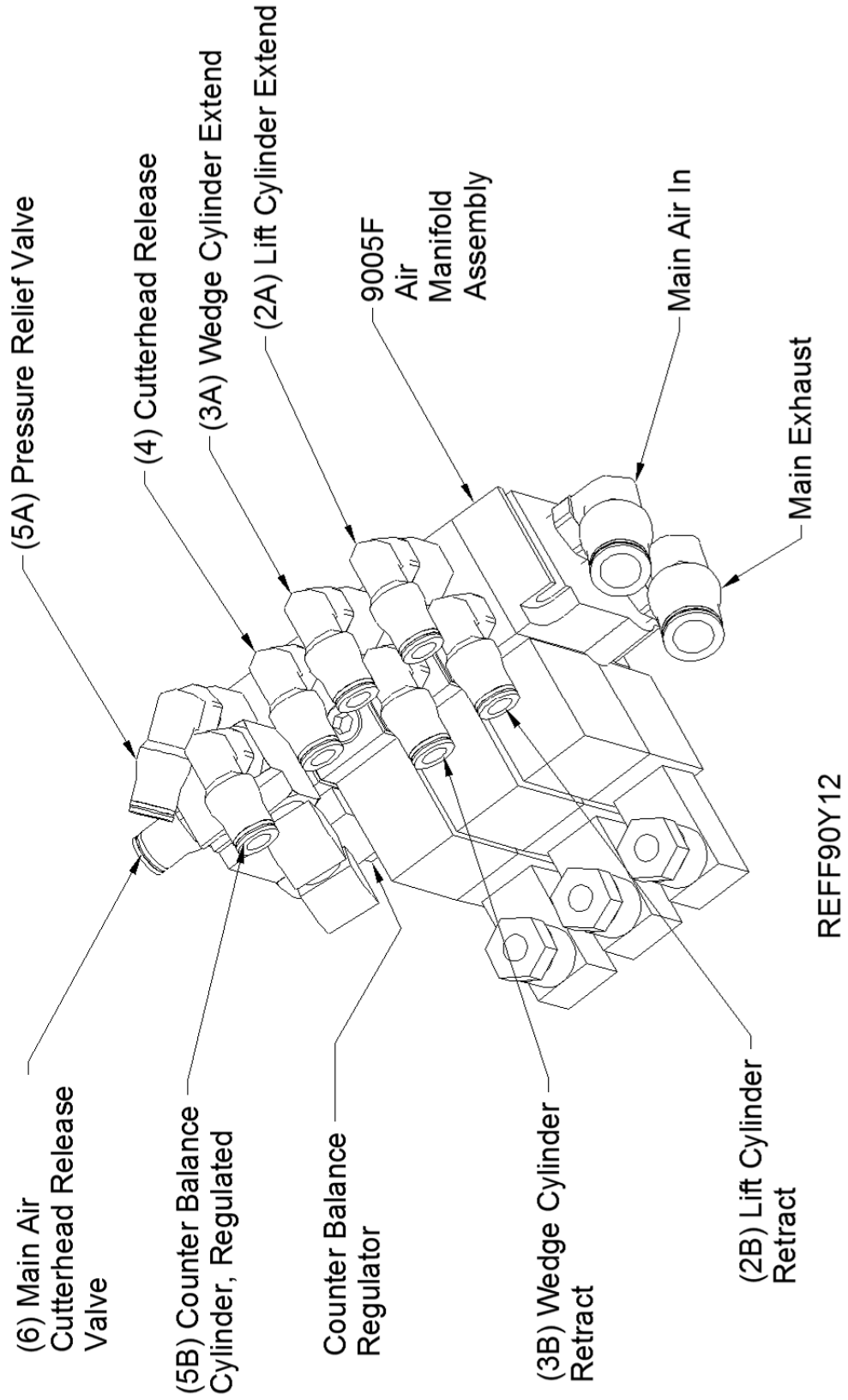

Electrical Enclosure F90M Series:

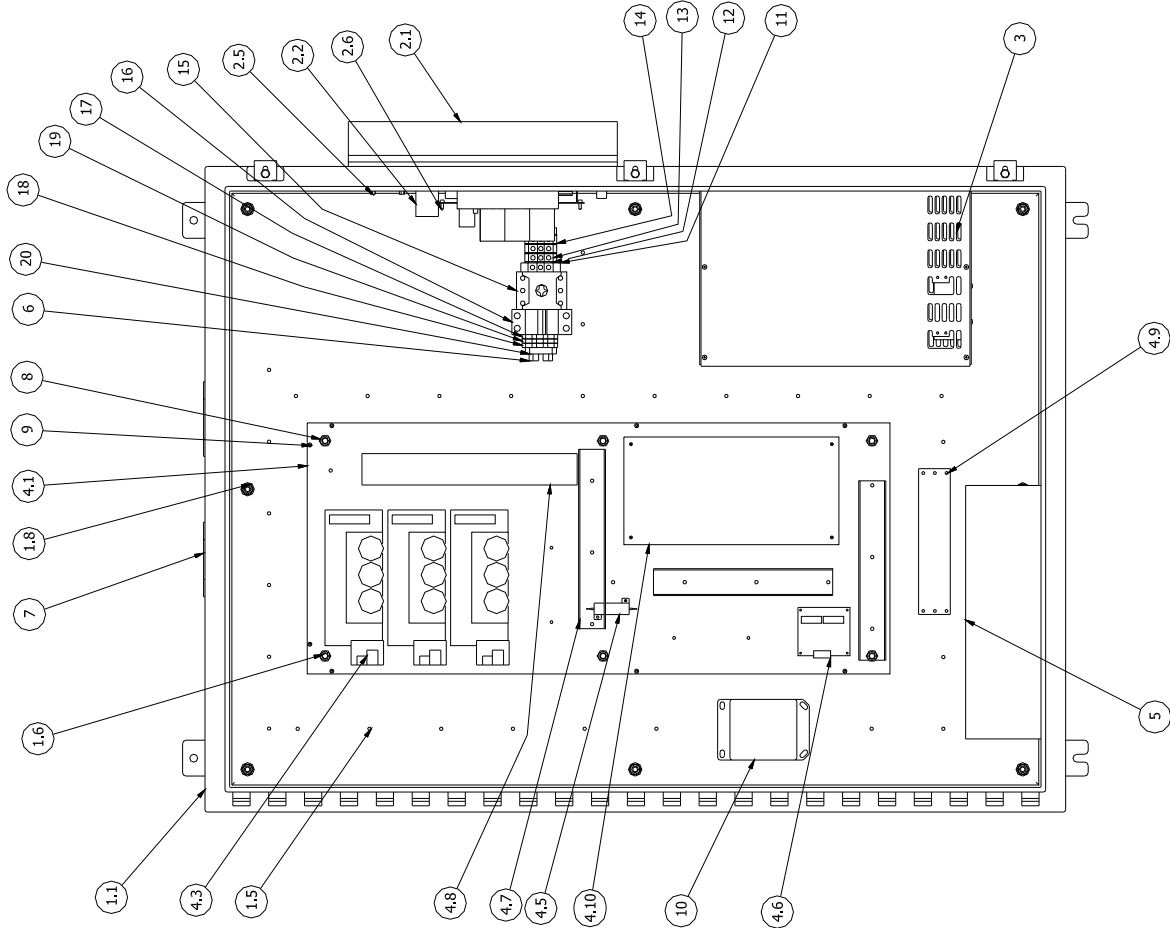

Rear Enclosure Parts List			
ITEM	QTY	PART NUMBER	DESCRIPTION
1	1	9023E	Rear Enclosure Assembly
1.5	1	9023F	Panel
1.6	6	ANSI B18.3 - 3/8 - 16 UNC - 1 3/4	Hexagon Socket Head Cap Screw
1.7	12	ANSI B18.2.2 - 3/8 - 16	Hex Jam Nut
1.8	8	IFI - 10.375 - 16	Hex Flange Nut
2	1	Heat Sink Spindle Amp Assembly	
2.1	1	9023H	Spindle Heat Sink
2.2	1	9023I	F90Y Spindle Amp
2.3	1	9023K	Spindle Amp Cover
2.4	1	650-1-28H	Cross Flow Fan
2.5	1	6486R	Braking Resistor 50 OHM, 1000 Watts
2.6	9	ANSI B18.3 - 6-40 UNF - 0.375	Hexagon Socket Head Cap Screw
3	1	650-1-27M	Computer Assembly, Complete
4	1	F99Y Drive Assembly	
4.1	1	650-1-27S	F67A Heat Sink
4.2	1	650-1-27R	F67A Drive Cover
4.3	5	650-1-27N	Dm Axis Drive
4.5	1	6486P	Charge Resistor 100 OHM 50 Watt
4.6	1	9023M	Thermal Board
4.7	4	6554L	Wire Track
4.8	1	6554M	Wire Track Cover
4.9	1	650-1-28H	Cross Flow Fan
4.10	1	9023R	Relay Board
5	1	650-5-3	Power Var
6	1	504-35-3F	Din Rail
7	2	9023P	IGUS Mounting Bracket
8	6	ANSI B18.2.2 - 3/8 - 16	Hex Nut
9	8	ANSI B18.3 - 6-40 UNF - 0.375	Hexagon Socket Head Cap Screw
10	1	9023Q	Main Contactor
11	1	9022	Ground Terminal Block, Large
12	1	9022A	Terminal Block End, Ground
13	3	9022B	Terminal Block, Large, Blue
14	3	9022E	End Barrier, Terminal Block Large
15	1	650-5-1	Disconnect Switch
16	1	504-35-3Q	Breaker, 3 Amp
17	1	514-7-74E	Ground Block
18	1	514-7-74C	Terminal Block, Blue
19	1	514-7-74D	Terminal Block, Grey
20	2	504-35-3M	End Cap

REF90Y13-05162006

650-1-27X Computer Enclosure Assembly:

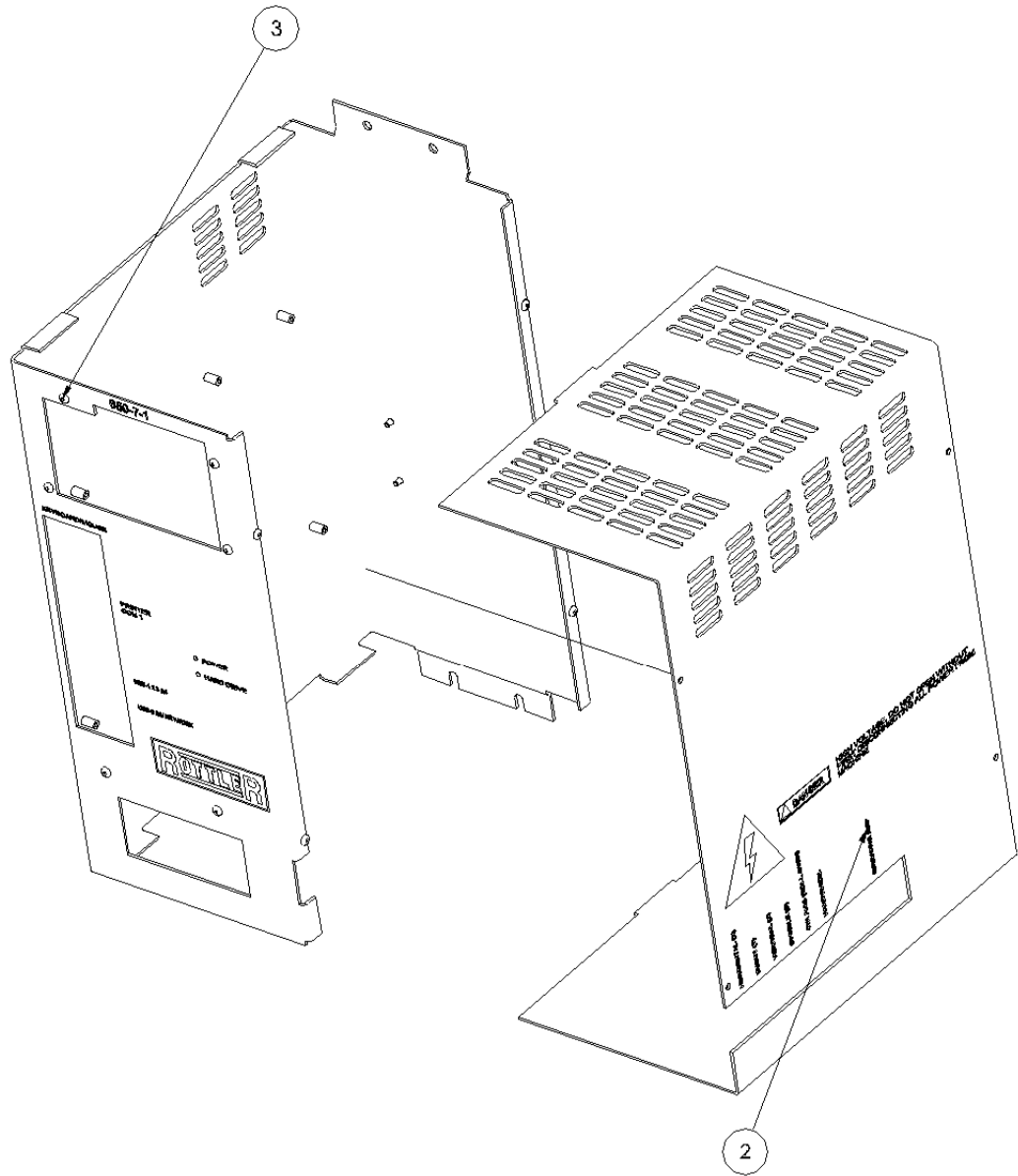

REF90Y19-02092007

Parts List			
ITEM	QTY	PART NUMBER	DESCRIPTION
1	1	650-1-27Y	Computer Case, Front
2	1	650-1-27Z	Case, Computer, Side

650-7-1 Computer Components:

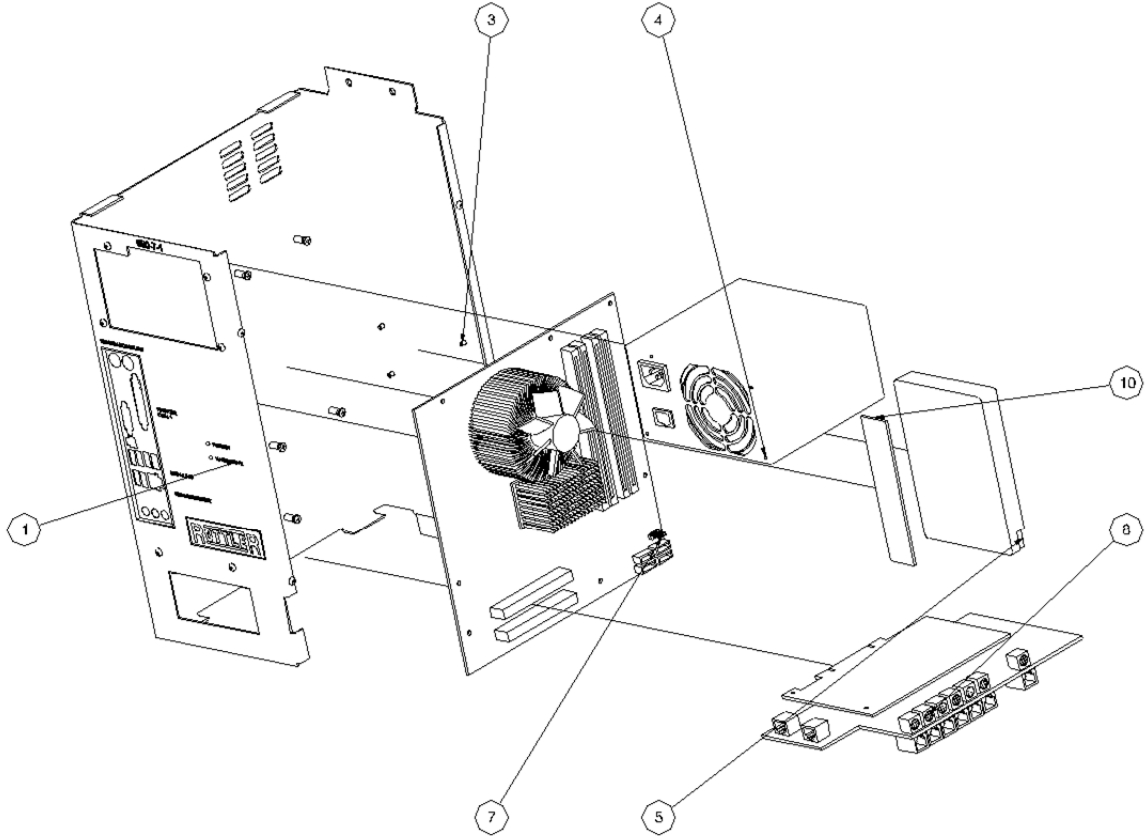

REF90Y-02092007

Parts List			
ITEM	QTY	PART NUMBER	DESCRIPTION
1	1	650-1-27Y	Computer Case, Front
2	1	650-1-27Z	Case, Computer, Side
4	1	650-7-1C	Power Supply
5	1	650-7-1F	Hard Drive
7	1	650-6-1A	Mother Board
8	1	650-1-27Q	PCI Card
9	2	650-1-29F	Bracket, PCI Card
10	1	650-7-1B	512 Mb DDR2 RAM

Spindle Base, Right Side:

Parts List			
ITEM	QTY	PART NUMBER	DESCRIPTION
7	1	6337	Air Actuator
8	1	6338	Limit Switch
20	2	506-4-3	Hole Plug 1-3/4 dia.
43	1	9006J	Cable Carrier Mount

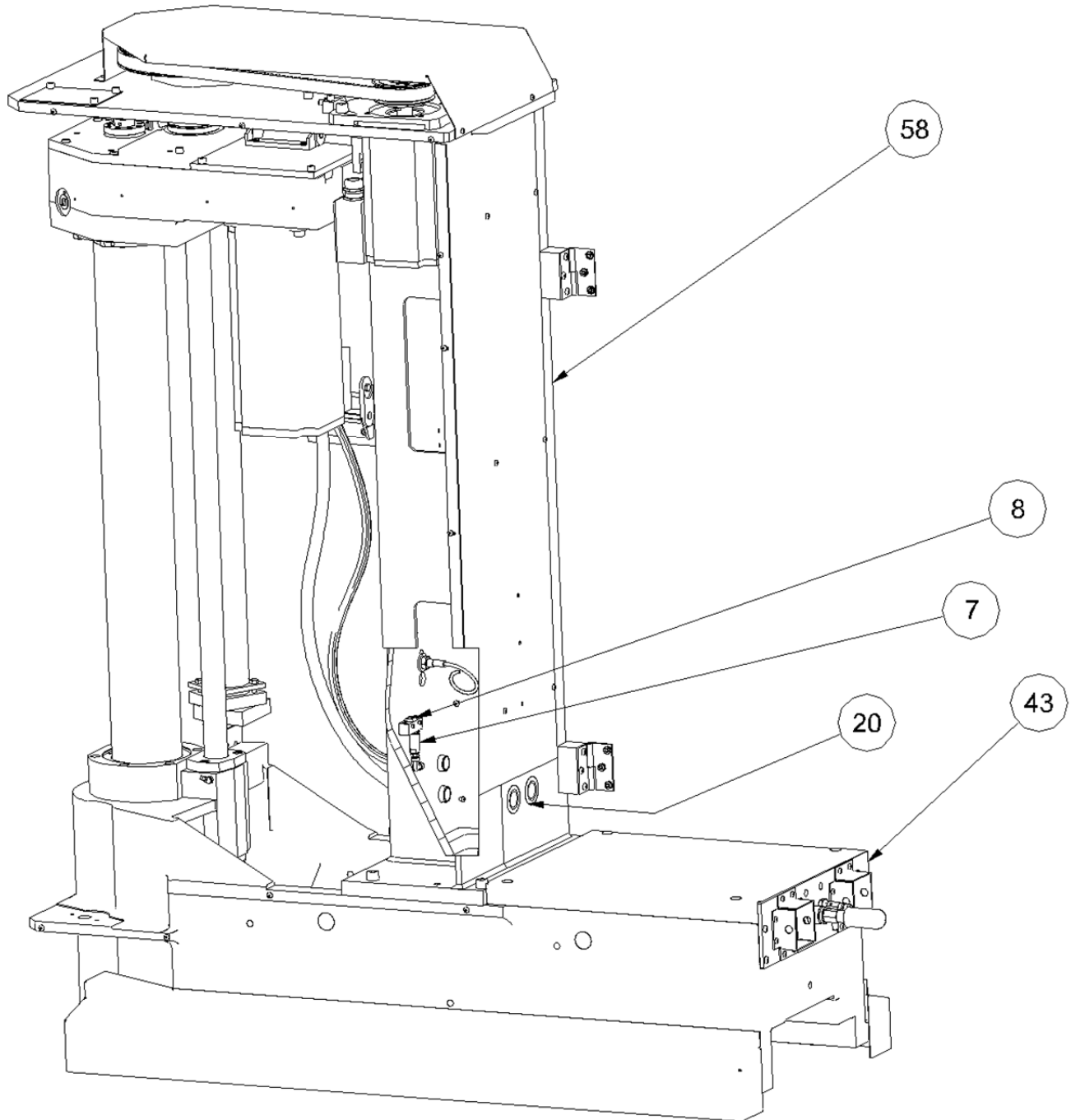

Spindle Base, Left Side:

Parts List			
ITEM	QTY	PART NUMBER	DESCRIPTION
10	1	9006	Rear Spindle Base Cover
27	2	6320J	Hinge, Spindle base cover
30	1	6452E	Bracket
43	1	502-37-71A	Ex-Air Cooler
44	1	514-3-86c	Cutterhead Release Switch Assembly
58.3	1	6297D	Cover, tower top.
58.5	2	6320G	Mounting Block
58.7	2	6354E	3/4 Strain Relief
58.10	1	6453F	Cable Cylinder

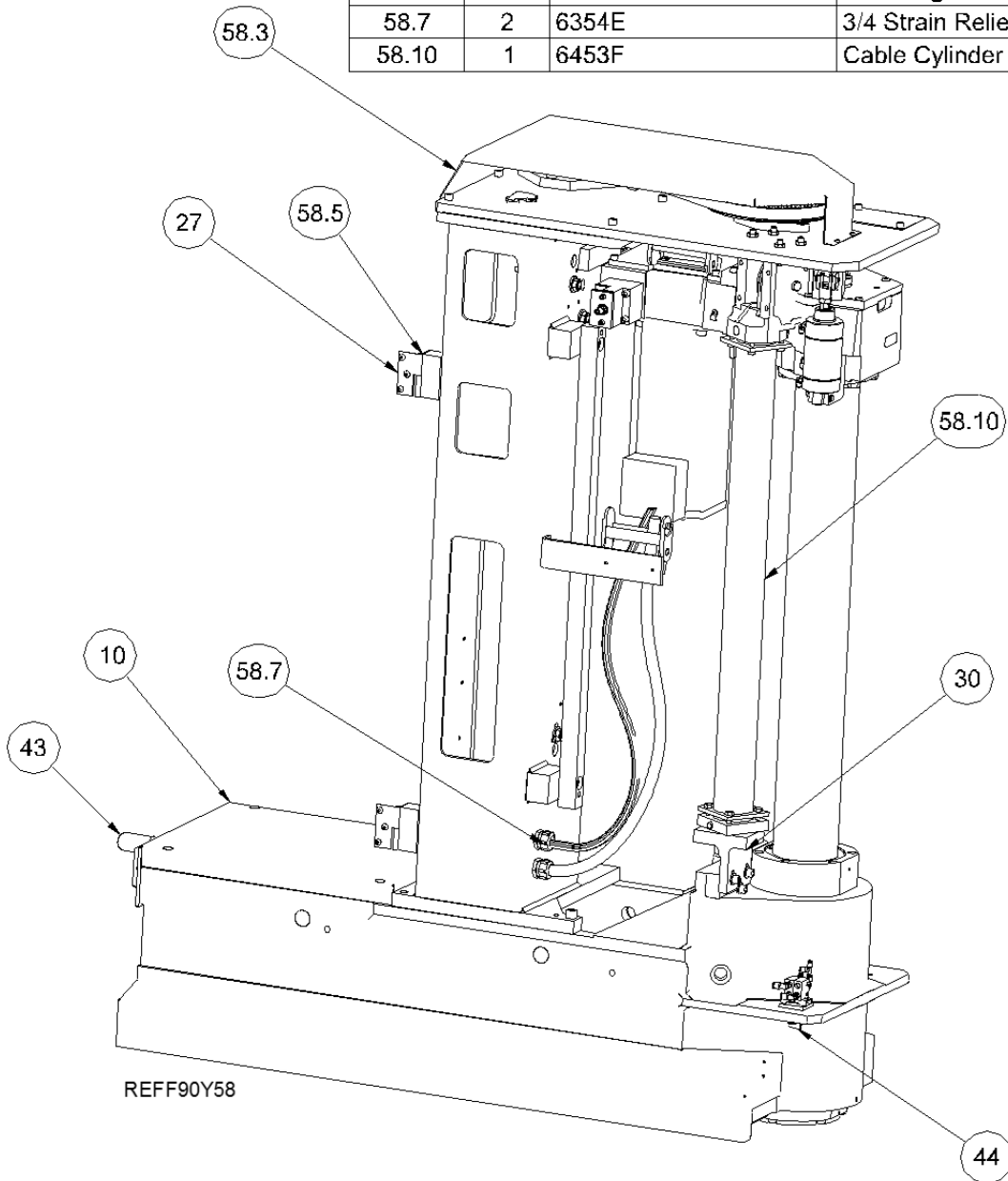

Spindle Base:

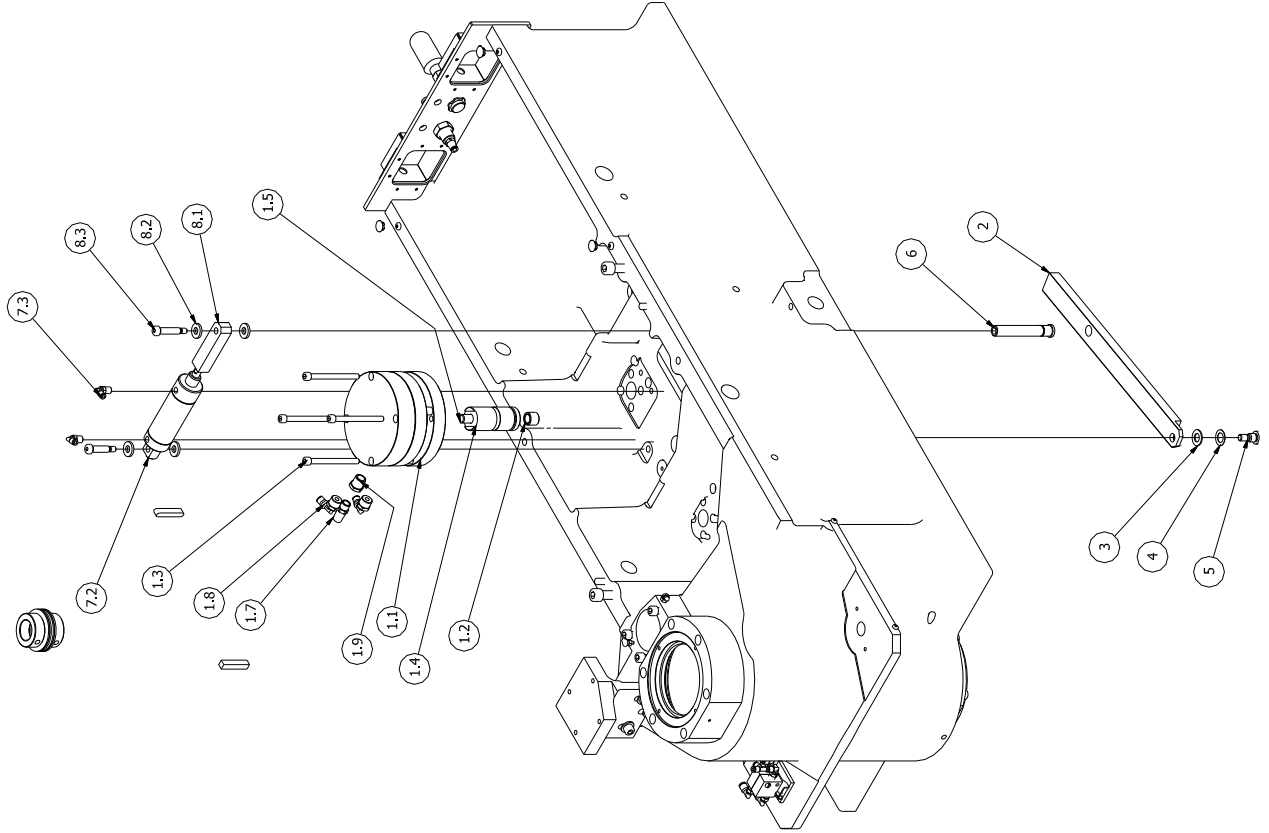

Spindle Base Parts List			
ITEM	QTY	PART NUMBER	DESCRIPTION
1	1	Tilt Lift assembly	
1.1	1	9005D	Tilt / Lift Cylinder
1.2	1	9005E	Threaded Insert - Marshal #8504 0064
1.3	4	ANSI B18.3 - 5/16 - 18 - 3	Hexagon Socket Head Cap Screw
1.4	1	9005A	Plunger
1.5	1	MF-45B	Socket Head Cap screw 1/2 - 13 UNC - 2 3/4
1.7	1	514-3-99	Filter
1.8	2	514-4-18B	1/4 poly x 1/4 npt 90, Legris metal
1.9	1	502-11-171	3/8 IPT to 1/4 IPT BUSHING
2	1	9005B	Wedge
3	1	100-19	Hardened Washer
4	1	100-42-13	Washer
5	1	502-9-83	Hexagon Socket Head Shoulder Screw
6	1	9005	Tilt Arm Pin
7	1	172-dp Cylinder	
7.1	1	172-dp piston	
7.2	1	172-dp cylinder	
7.3	2	Legris angle 13x532	
7.4	2	100-28-18	Washer
7.5	1	ANSI B18.3 - 0.375 x 1.25	Hexagon Socket Head Shoulder Screw
8	1	ANSI B18.3	Wedge Arm Assembly
8.1	1	9005C	Rod Eye Tilt
8.2	2	100-28-18	Washer
8.3	1	ANSI B18.3 - 0.375 x 1.5	Hexagon Socket Head Shoulder Screw

REF90Y17

Rear Spindle Base:

F99Y Rear Spindle Base			
ITEM	QTY	PART NUMBER	DESCRIPTION
1	1	9006J	Conduit Mount Plate F90 Spindle Base
2	4	9023P Female	iGUS Bracket Set
3	1	502-11-17X	Bulk Head Fitting
4	1	6449	Relief Valve
5	1	502-37-71A	EX-Air Cabinet Cooler

REF F90Y-02092007

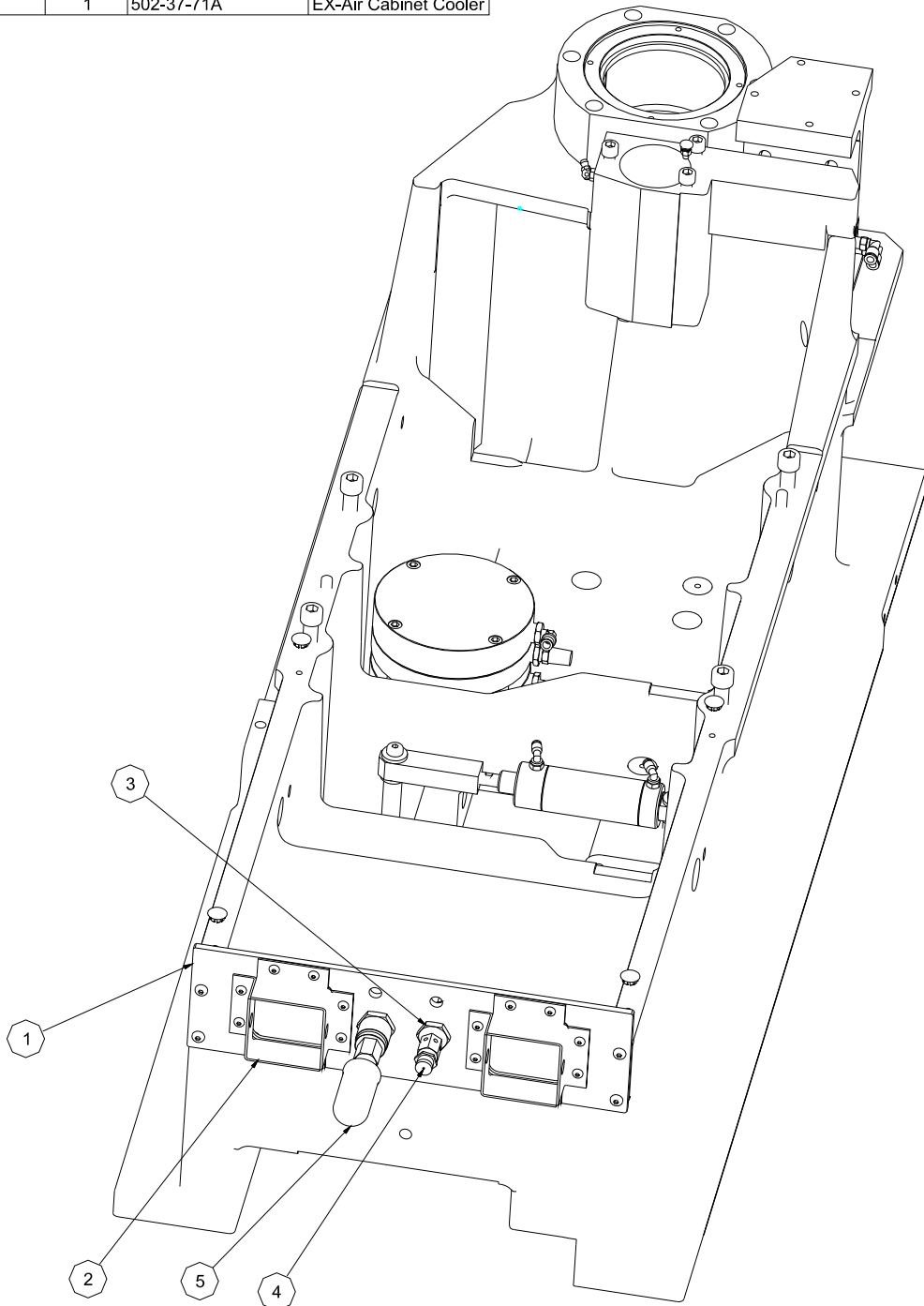

Tilt Lift Cylinder:

Parts List			
ITEM	QTY	PART NUMBER	DESCRIPTION
1	1	Tilt Lift assembly	
1.1	1	9005D	Tilt / Lift Cylinder
1.2	1	9005E	Threaded insert Marshal #8504 0064
1.3	4	ANSI B18.3 - 5/16 - 18 - 3 1/2	Hexagon Socket Head Cap Screw
1.4	1	9005A	Plunger
1.5	1	Mf-45B	Socket Head Cap screw 1/2 - 13 UNC - 2 3/4
1.7	2	514-3-99	Filter
1.8	2	514-4-18B	1/4 poly x 1/4 npt 90, Legris metal
1.9	2	502-11-17i	3/8 IPT to 1/4 IPT BUSHING

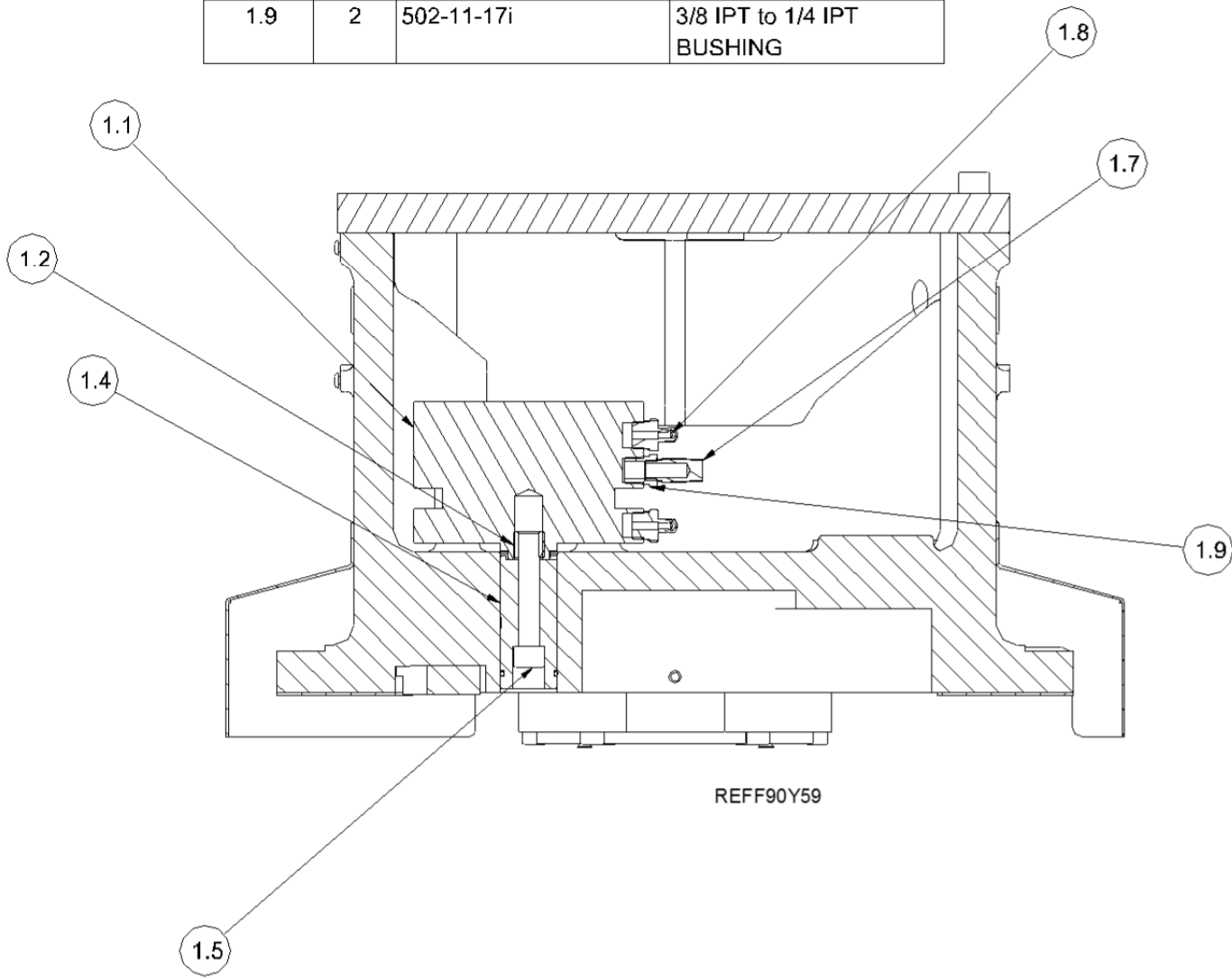

Tilt Cylinder:

F99Y Tilt Cylinder Section			
ITEM	QTY	PART NUMBER	DESCRIPTION
1	1	9005	Pin, tilt Arm
2	1	502-6-7	Cylinder, Air, Tilt
3	2	100-28-18	Washer, Hardened
4	1	ANSI B18.3 - 0.375 x 1.25 ANSI B18.3	Hexagon Socket Head Shoulder Screw
5	1	9005C	Rod Eye Tilt
6	2	100-28-18	Wahser, Hardened
7	1	ANSI B18.3 - 0.375 x 1.5 ANSI B18.3	Hexagon Socket Head Shoulder Screw
8	1	9005B	Wedge
58	2	6037D	Set Collar
59	4	6037C	Bellville Spring

REF F90Y25-02/02/2007

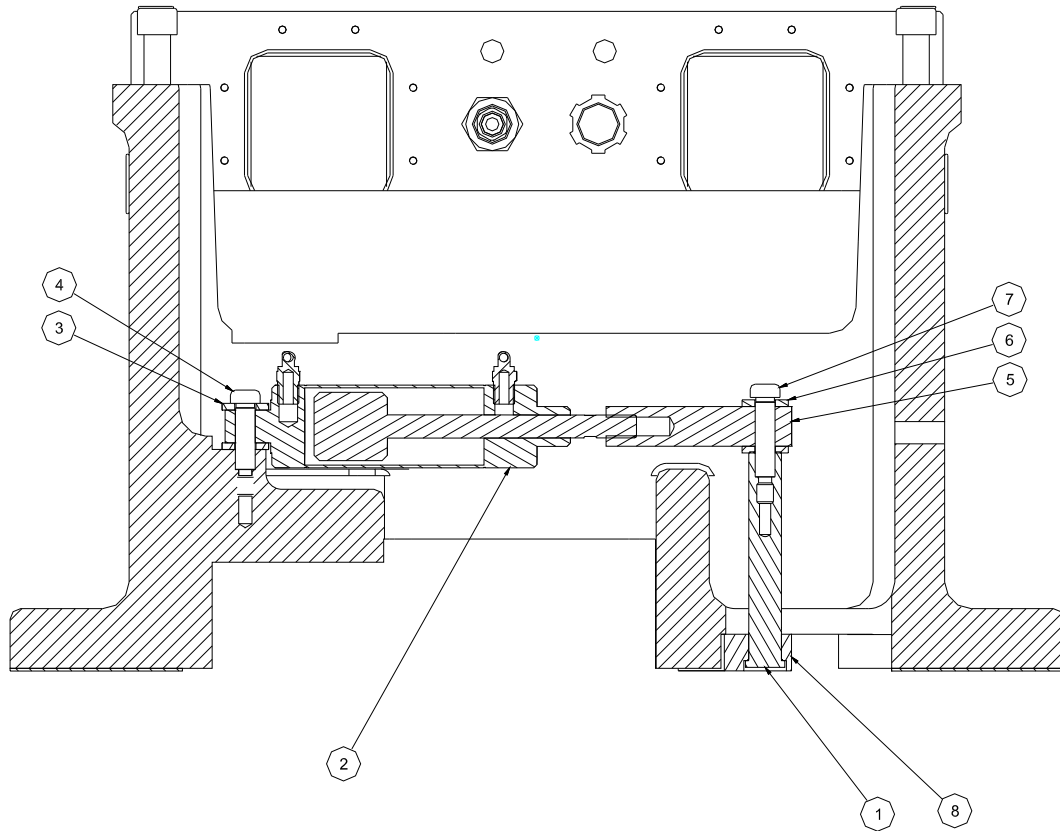

Vertical Ballscrew Assembly:

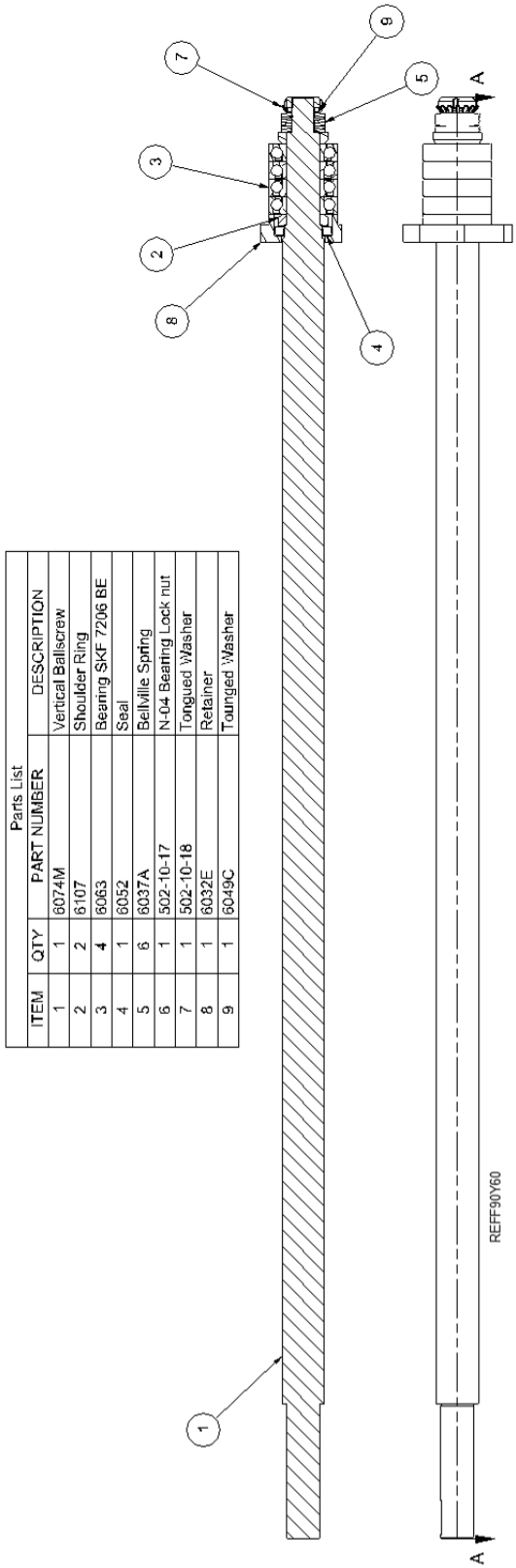

Parts List

ITEM	QTY	PART NUMBER	DESCRIPTION
1	1	6074M	Vertical Ballscrew
2	2	6107	Shoulder Ring
3	4	6063	Bearing SKF 7206 BE
4	1	6052	Seal
5	6	6037A	Belleville Spring
6	1	502-10-17	N-04 Bearing Lock nut
7	1	502-10-18	Tongued Washer
8	1	6032E	Retainer
9	1	6049C	Tongued Washer

Vertical Ballscrew Bumper Package:

Parts List			
ITEM	QTY	PART NUMBER	DESCRIPTION
1	2	6037D	Set Collar
2	4	6037C	Bellville Spring

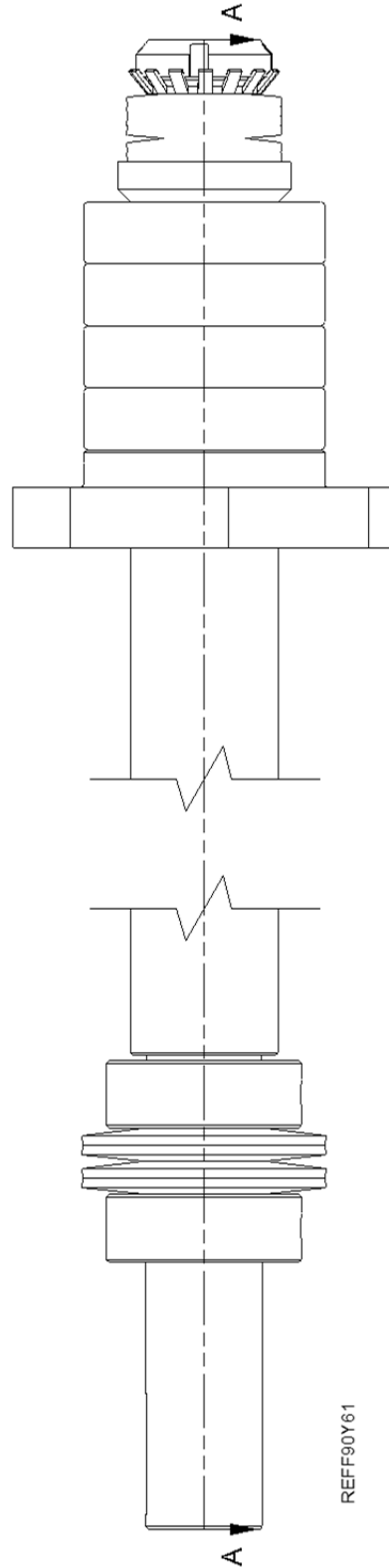
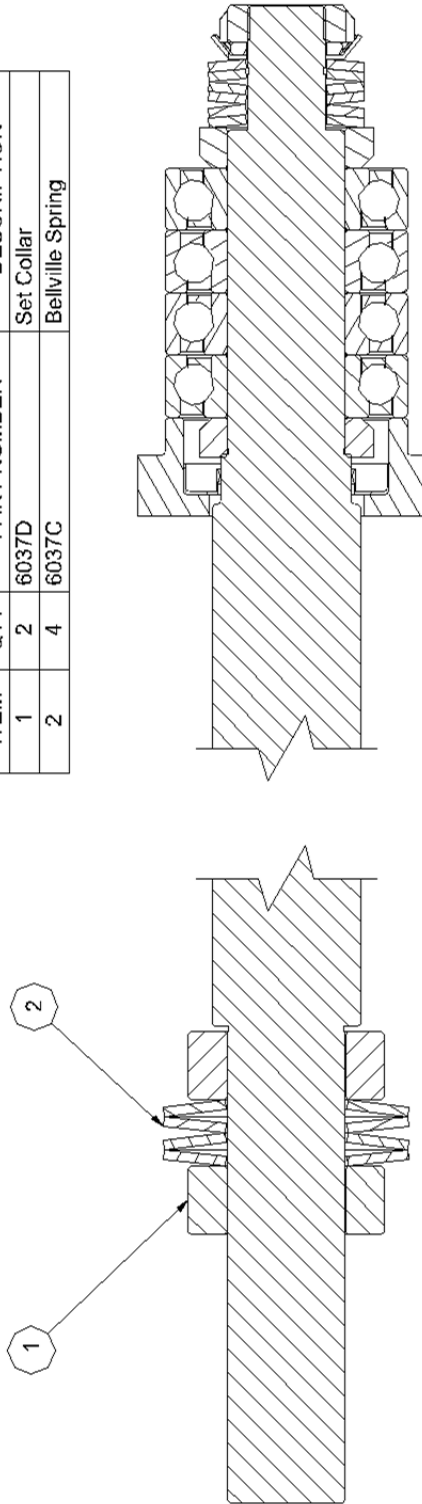

REF90Y61

Lower Spindle:

F99Y Lower Spindle Section			
ITEM	QTY	PART NUMBER	DESCRIPTION
1	2	6223	Outer Spindle Nut
2	1	6224	Upper Retainer
3	1	6248	Square Ring
4	1	6249	Felt Oiler
5	1	6250	Felt Oiler
6	1	6251	Square Ring
7	1	6219Q	Spindle Base
8	1	6221C	Flanged Sleeve
9	2	6222A	Outer Spindle Bushing
10	1	6225A	Lower Bearing Carrier
11	1	6247A	Retainer
12	4	ANSI B18.3 - 3/8-16 UNC x 0.57	Hexagon Socket Set Screw - Oval Point
14	1	6166N	Outer Spindle
15	1	6167N	Innere Spindle
16	3	6116E	Bearing (set of 3)
17	1	6172E	Bearing Spacer Set
18	1	6116F	Shoelock Nut
19	1	6305D	Throwback Ring
20	1	6169N	Draw Bar
21	1	6169M	Drawbar Nose
22	1	6183A	Spring Spacer
23	1	6182A	Draw Bar Spring
24	1	6253	Retaining Ring
13.25	1	6090B	Key
13.56	1	6790U	Key
58	2	6037D	Set Collar
59	4	6037C	Belville Spring

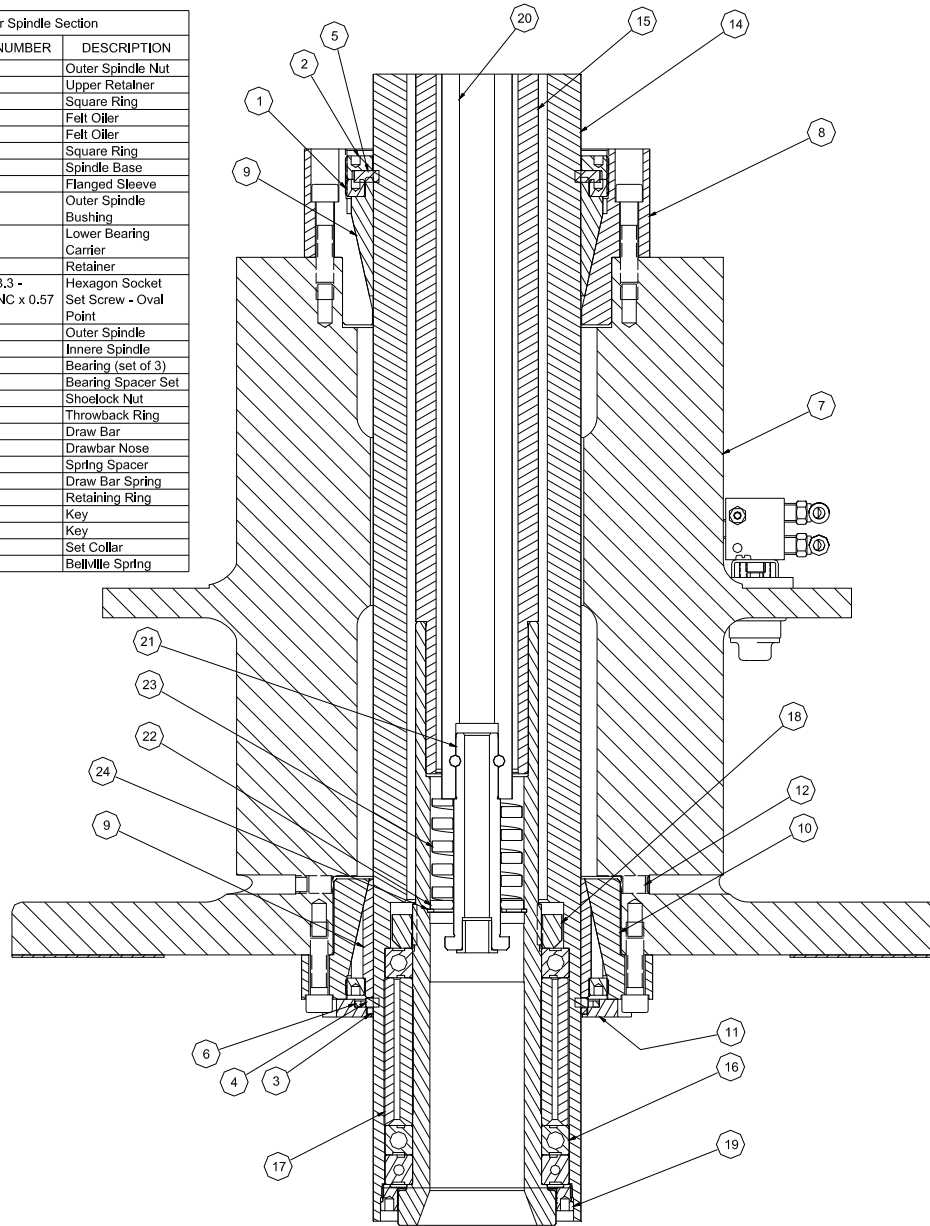

REF99Y26-02/09/2007

Draw Bar / Centering Assembly:

Parts List			
ITEM	QTY	PART NUMBER	DESCRIPTION
1	1	6166N	Outer Spindle
2	1	6167G	
2.1	1	6167N	Innere Spindle
2.2	1	6167J	
2.3	2	ANSI B18.8.2 - 3/16 x 1	Pin - Hardened Ground Machine Dowel
3	3	6116E	Bearing (set of 3)
4	1	6172C	Spacer Inner
5	1	6172D	Spacer Outer
6	1	6116F	Shoelock Nut
7	2	6115A	Bearing, Upper spindle
8	1	6123F	Spacer
9	1	6113L	Index Bushing
10	1	6759W	Driven Sprocket 64 T.
11	1	6091C	Spindle Adjustment Nut
12	4	Mf-26	Socket Head Cap screw 5/16 - 18 UNC - 1 3/4
13	1	6305D	Throwback Ring
14	4	6113	Belleville Spring BS-210 75# load
15	1	6169U	Draw Bar Assembly
15.1	1	6169N	Draw Bar
15.2	1	6169M	Drawbar Nose
15.3	1	6183A	Spring Spacer
15.4	2	ANSI B18.8.2 - 1/4 x 3/4	Pin - Hardened Ground Machine Dowel
15.5	1	6243L	Bearing, Oilite
15.6	1	6182A	Draw Bar Spring
16	1	6253	Retaining Ring
17	1	6180A	Cap, Compression Ring
18	1	6186	Key
19	8	ANSI B18.3 - No. 10 - 24 UNC - 7/16	Socket Head Cap screw No. 10 - 24 UNC - 7/16
20	1	6090B	Key

REF90Y45-02142007

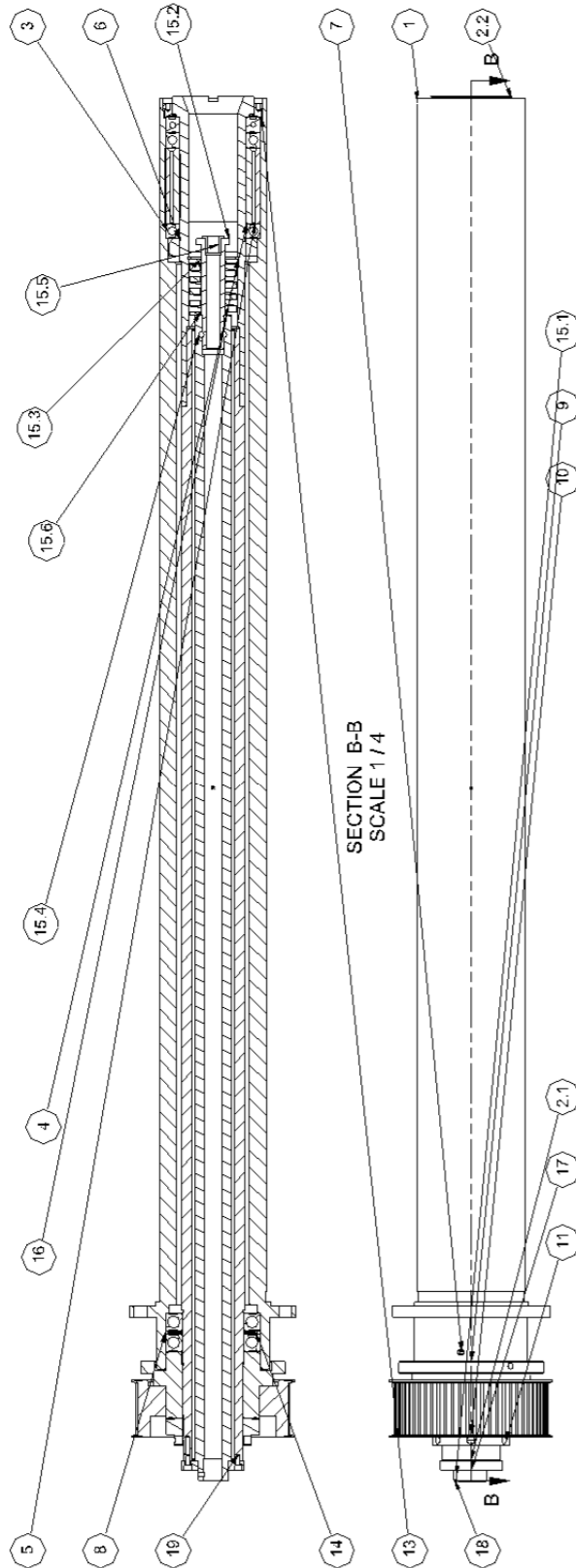

Y-Axis Assembly:

F90 Spindle Base Way Assembly			
ITEM	QTY	PART NUMB	DESCRIPTION
1	2	514-4-16A	#10-32 banjo fitting
2	2	514-4-17J	1/8 POLY X #10-32 STRAIGHT
3	2	9003A	Wiper Plate, Y-Axis
4	1	9003B	Wiper, Y-Axis
5	4	9003C	Wiper, Spindle Base
6	6	9024	Gib, Spring Bar
7	3	9024B	Y-axis guide bar
8	1	9024C	Y-axis guide bar
9	24	9024E	Belleville Washer BS 0.750-0.312-0.8
10	4	9108	Wiper, Solid Way Spindle Base
11	4	9108A	Wiper, Solid Way Spindle Base
12	8	MF-12	S.H.C.S. 1/4 - 20 UNC - 1/2
13	3	MF-186B	No. 10 - 24 Nylock Nut
14	12	MF-210A	5/16 x 3/4 Dowel Pin
15	28	MF-42	S.H.C.S. 1/2 - 13 UNC - 1
16	19	MF-88A	Socket Button Head DESIGNATION}
17	3	MF-90	Socket Button Head DESIGNATION}

ref#90 spindle base Way Assembly 1 - 3/5/2008

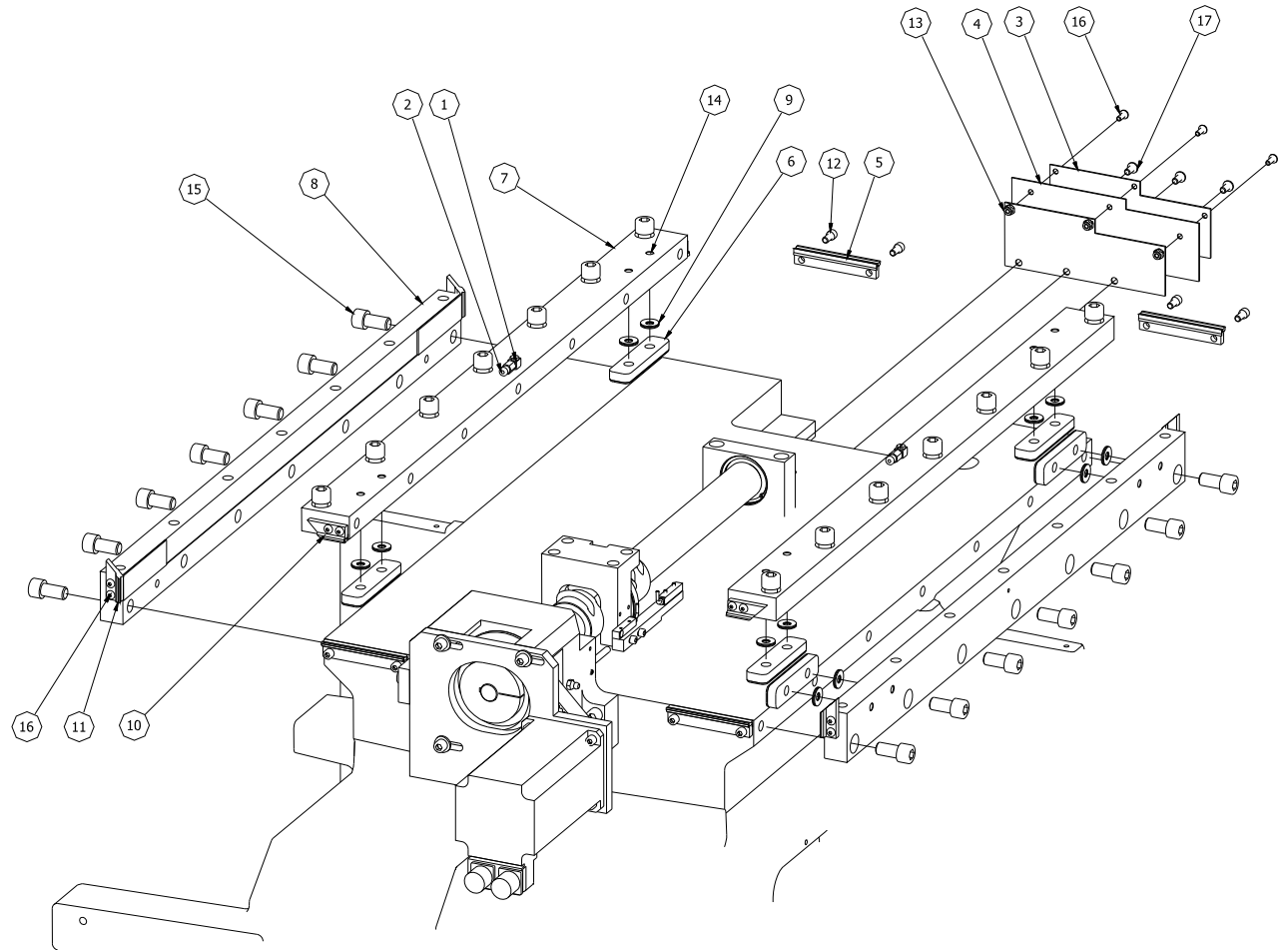

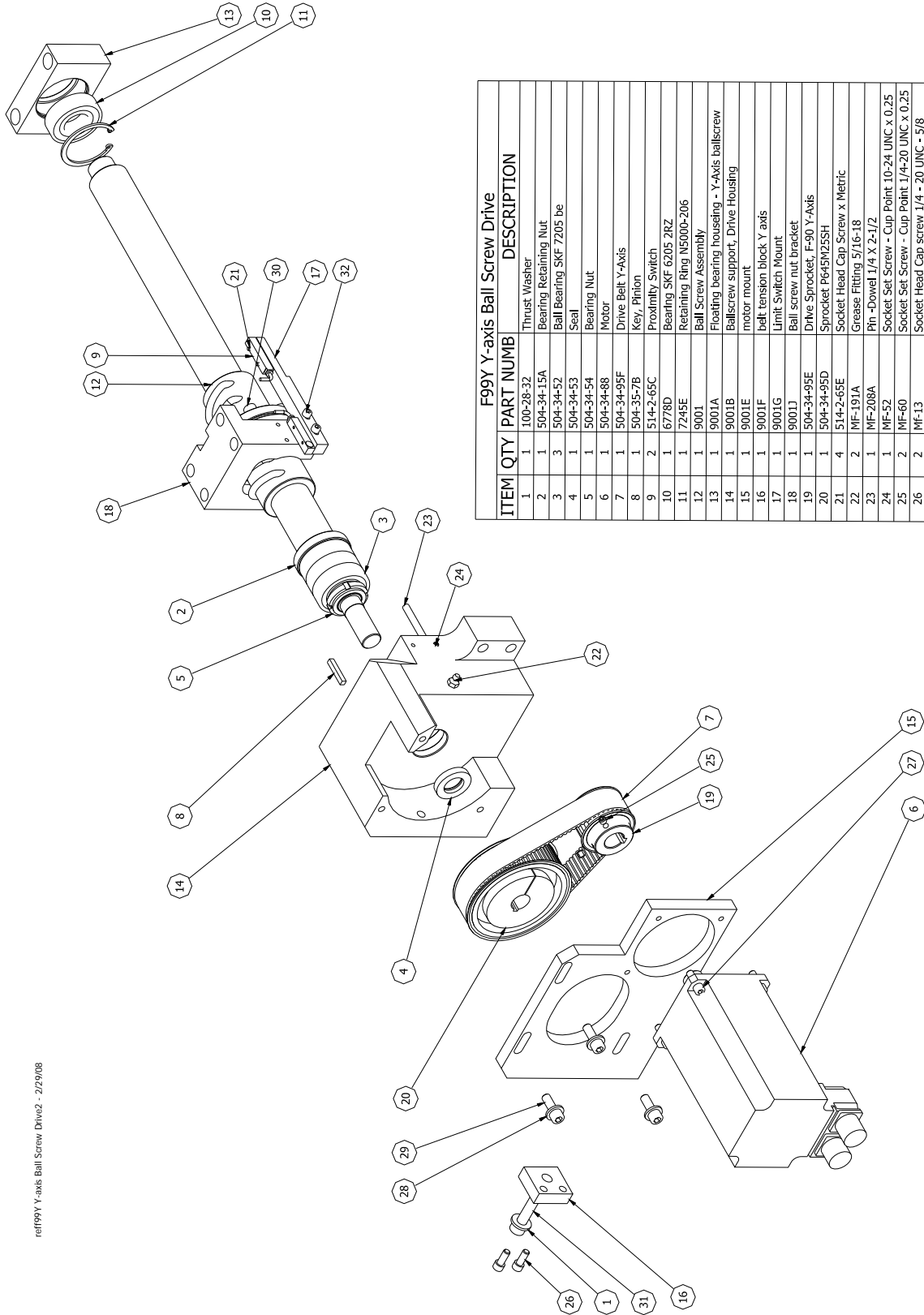

F99Y Y-axis Ball Screw Drive		
ITEM	QTY	PART NUMB DESCRIPTION
1	1	100-28-32 Thrust Washer
2	1	504-34-15A Bearing Retaining Nut
3	3	504-34-52 Ball Bearing SKF 7205 be
4	1	504-34-53 Seal
5	1	504-34-54 Bearing Nut
6	1	504-34-88 Motor
7	1	504-34-95F Drive Belt Y-Axis
8	1	504-35-7B Key, Pinion
9	2	514-2-65C Proximity Switch
10	1	6778D Bearing SKF 6205 2RZ
11	1	7245E Retaining Ring N5000-206
12	1	9001 Ball Screw Assembly
13	1	9001A Floating bearing housing - Y-Axis ballscrew
14	1	9001B Ballscrew support, Drive Housing
15	1	9001E motor mount
16	1	9001F belt tension block Y axis
17	1	9001G Limit Switch Mount
18	1	9001J Ball screw nut bracket
19	1	504-34-95E Drive Sprocket, F-90 Y-Axis
20	1	504-34-95D Sprocket P64EM25SH
21	4	514-2-65E Socket Head Cap Screw x Metric
22	2	MF-191A Grease Fitting 5/16-18
23	1	MF-208A Pin - Dowel 1/4 X 2-1/2
24	1	MF-52 Socket Set Screw - Cup Point 10-24 UNC x 0.25
25	2	MF-60 Socket Set Screw - Cup Point 1/4-20 UNC x 0.25
26	2	MF-13 Socket Head Cap screw 1/4 - 20 UNC - 5/8
27	4	MF-14 Socket Head Cap Screw 1/4-20 UNC - 3/4
28	3	MF-177 Flat Washer
29	3	MF-23 Socket Head Cap screw 5/16 - 18 UNC - 1
30	4	MF-24 Socket Head Cap Screw 5/16 - 18 - 1 1/4
31	1	MF-33 Socket Head Cap screw 3/8 - 16 UNC - 1 1/2
32	2	MF-6 Socket Head Cap screw No. 10 - 24 UNC - 3/4

ref99Y Y-axis Ball Screw Drive2 - 2/29/08

Y-Axis Ballscrew Drive:

Top Plate Assembly:

F99Y Top Plate Assembly			
ITEM	QTY	PART NUMBER	DESCRIPTION
1	4	6037C	Bellville Spring
2	2	6037D	Set Collar
3	1	6074M	Vertical Ballscrew
4	1	6297D	Cover, tower top.
5	1	6451Q	Block, Adjusting Belt, Servo Motor
6	1	6451U	Motor Mount Plate
7	1	6481G	Servo Motor
8	1	6759B	Drive Sprocket
9	1	6759D	Driven Sprocket
10	1	6759E	Bushing, Driven Sprocket
11	1	6759F	Flange Block
12	1	6759G	Backup Flange
13	1	6759T	Bushing, Drive Sprocket
14	1	9009	Top Plate
15	1	9009A	Cover Plate
16	5	Mf-79	Hexagon Socket Flat Countersunk Head Cap Screw
17	1	6759X	Spindle Drive Belt

ref90y2h-0209/2007

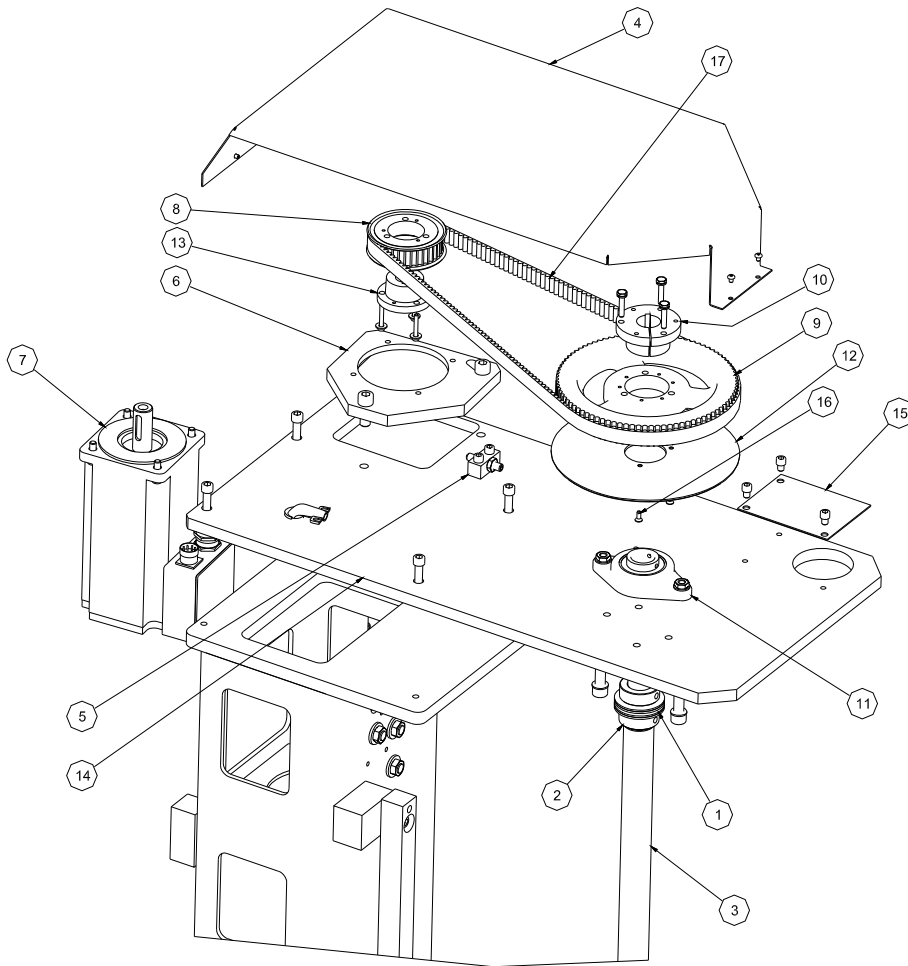

Upper Housing tower Guide:

F99Y Upper Housing Tower Guide Assembly			
ITEM	QTY	PART NUMBER	DESCRIPTION
1	1	6760J	Bracket
2	1	6760K	Inner Bearing
3	1	6760L	Outer Bearing
4	2	6760F	Bellville Spring
5	1	6213E	Stop Block, Vertical
6	1	6314K	Cable carrier
7	1	6174B	Bracket
8	1	7210B	Clevis Pin
9	1	6173B	Actuator Arm
10	1	6189B	Clevis Pin
11	1	6188C	Mount Bracket
12	1	6204A	Air Cylinder
13	1	6205	Clevis
14	1	6189A	Clevis Pin

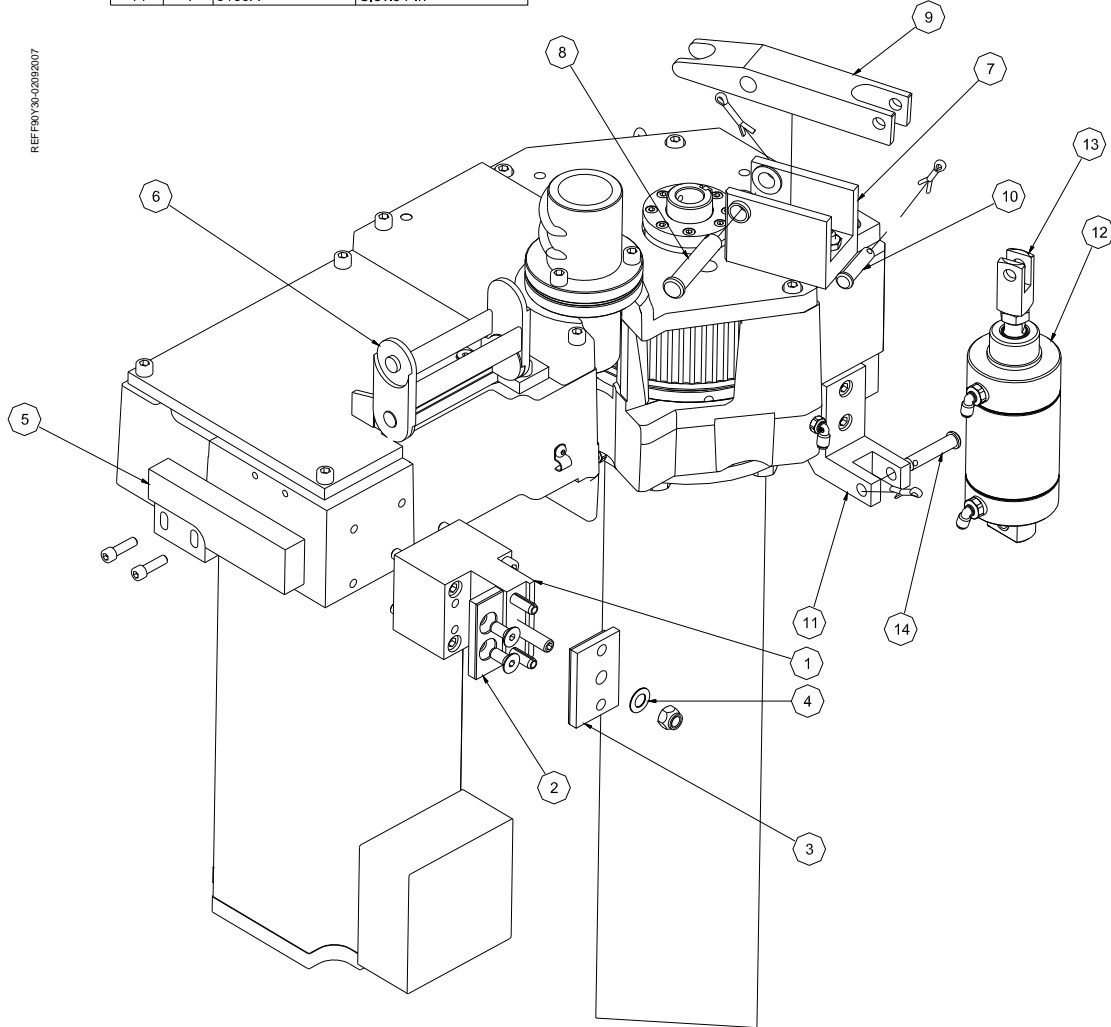

Upper Housing:

F90Y Upper Housing Section			
ITEM	QTY	PART NUMBER	DESCRIPTION
1	1	6111U	Upper Housing F88/F99
2	1	6112R	Upper Housing Cover
3	1	6112g	Cover
4	1	6790S	Motor Mount Plate F88/F99
5	1	6759S	Drive Sprocket 24T.
6	1	6790U	Servo Motor, Spindle Drive
7	2	6115A	Bearing, Upper spindle
8	1	6123F	Spacer
9	1	6113L	Index Bushing
10	1	6759W	Driven Sprocket 64 T.
11	4	6113	Belleville Spring BS-210 75# load
12	1	6186	Key
13	1	6090B	Key
14	1	BelT Tension Adjustment	3/8-16 UNC X 2.75 HHMS
15	2	514-4-18	1/8 npt x 1/8 pdky 90

REF90731-02092007

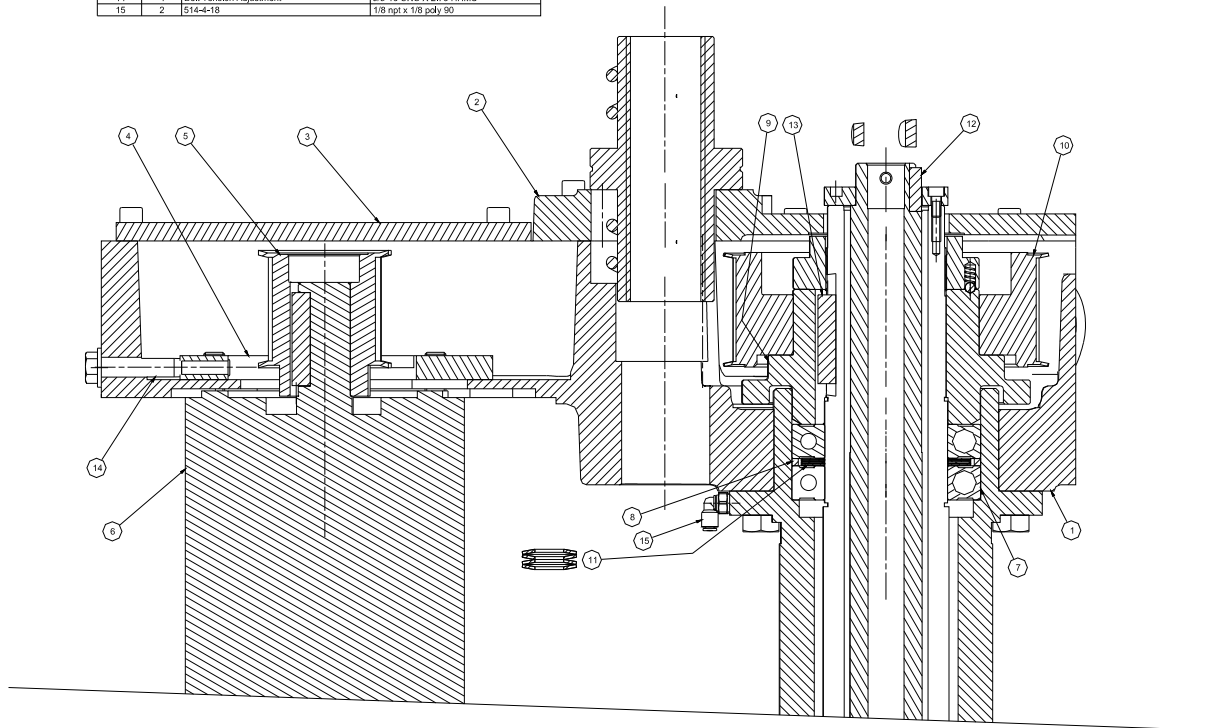

Pendant Swing Arm:

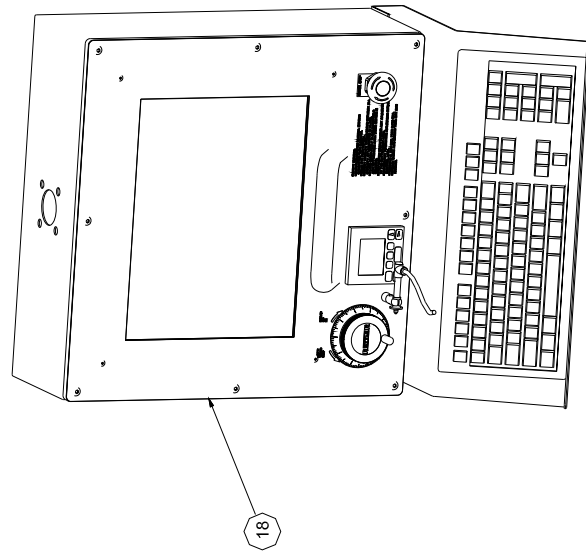
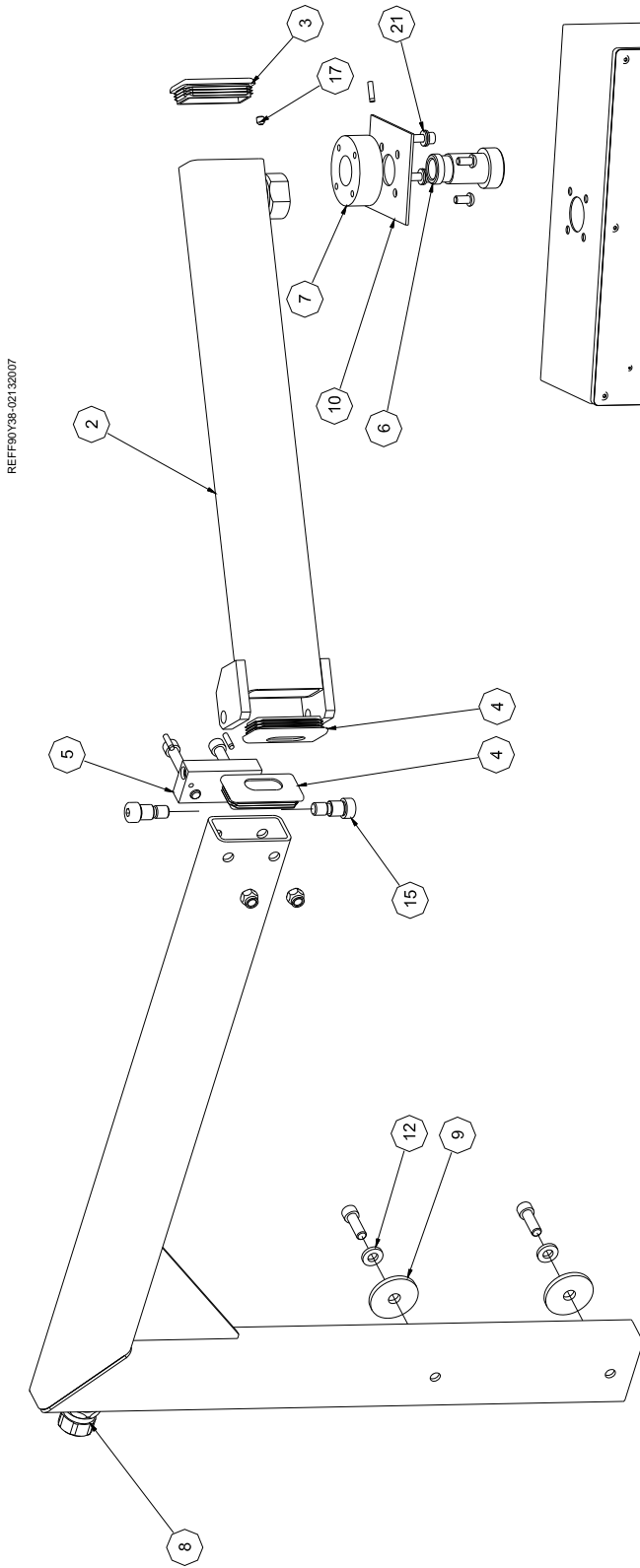

F99Y Pendant Swing Arm Assembly		
ITEM	QTY	PART NUMBER DESCRIPTION
1	1	6201L Swing Arm Support
2	1	6200B Swing arm
3	1	6200J Plug
4	2	6200L Tubing Plug, Slotted
5	1	6201H Hinge Block
6	1	6197B Swivel
7	1	6196b Swivel Housing
8	1	6358 1" Straight Sealtight Fitting
9	2	502-3-17 Washer
10	1	6385E Support Plate
11	2	MF-44 S.H.C.S. 1/2 - 13 UNC - 1 1/2
12	2	Washer
13	2	MF-41A S.H.C.S. 1/2 - 13 UNC - 3 1/2
15	2	6201J Hexagon Socket Head Shoulder Screw
17	2	MF-71 Hexagon Socket Set Screw - Cup Point
18	1	Pendant Assembly
19	2	MF-96 Socket Button Head DESIGNATION
20	2	MF-31 S.H.C.S. 3/8 - 16 UNC - 1
21	4	100-28-32 Thrust Washer
22	3	MF-204 1/4 x 1 Dowel Pin
23	2	MF-186 1/2 - 13 Nylock Nut

Pendant Assembly:

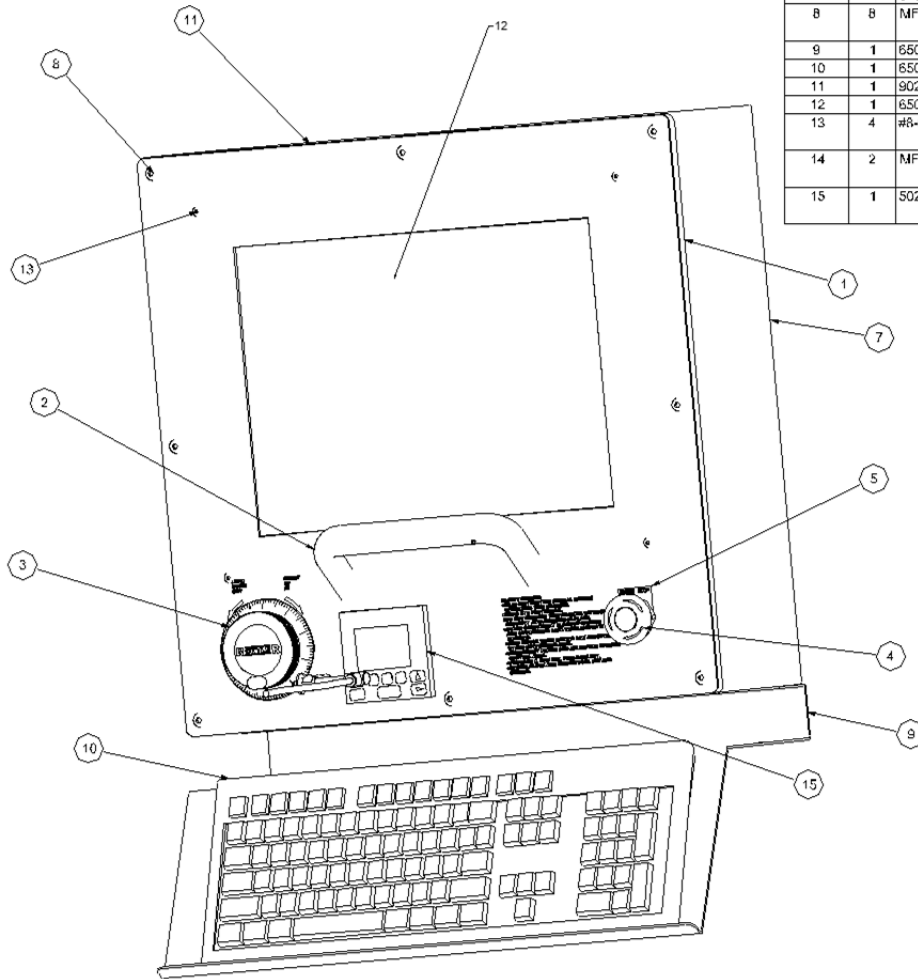

Parts List			
ITEM	QTY	PART NUMBER	DESCRIPTION
1	1	6198M	Pendant Face Plate
2	1	650-1-2G	Handle, Pendant
3	1	6428	Electronic Handwheel
4	1	6389D	E-Stop Button
5	1	6389B	E-Stop Nameplate
6	7	ANSI B16.6.3 - 6 - 32	Hex Machine Screw Nut
7	1	6198L	Pendant Enclosure
8	8	MF-01	Socket Button Head DESIGNATION
9	1	650-1-28M	Keyboard Tray
10	1	650-5-23	Keyboard
11	1	9023B	Face Plate Overlay
12	1	650-1-26X	Touch Screen
13	4	#8-0.875-UNC	Socket Button Head DESIGNATION
14	2	MF21A	S.H.C.S. 5/16 - 18 UNC - 1:2
15	1	502-12-7B	Digital Read Out Assembly

REF90Y35-02132007

Way Cover Assembly:

REF F90Y36-02122007

Parts List			
ITEM	QTY	PART NUMBER	DESCRIPTION
1	1	Way Cover	
2	1	B080K	
3	1	9011	Way Cover Support ass'y
4	8	ANSI B18.22.1 - 1/2 - narrow - Type A	Washer A
5	4	MF-44	Socket Head Cap screw 1/2 - 13 UNC - 1 1/2
6	2	MF-96	Socket Button Head Cap Screw 3/8 - 16 x 3/4
7	2	ANSI B18.2.2 - 1/2 - 13	Hex. Nut
8	4	ANSI B18.3 - 3/8 - 16 x 1	Hexagon Socket Button Head Cap Screw

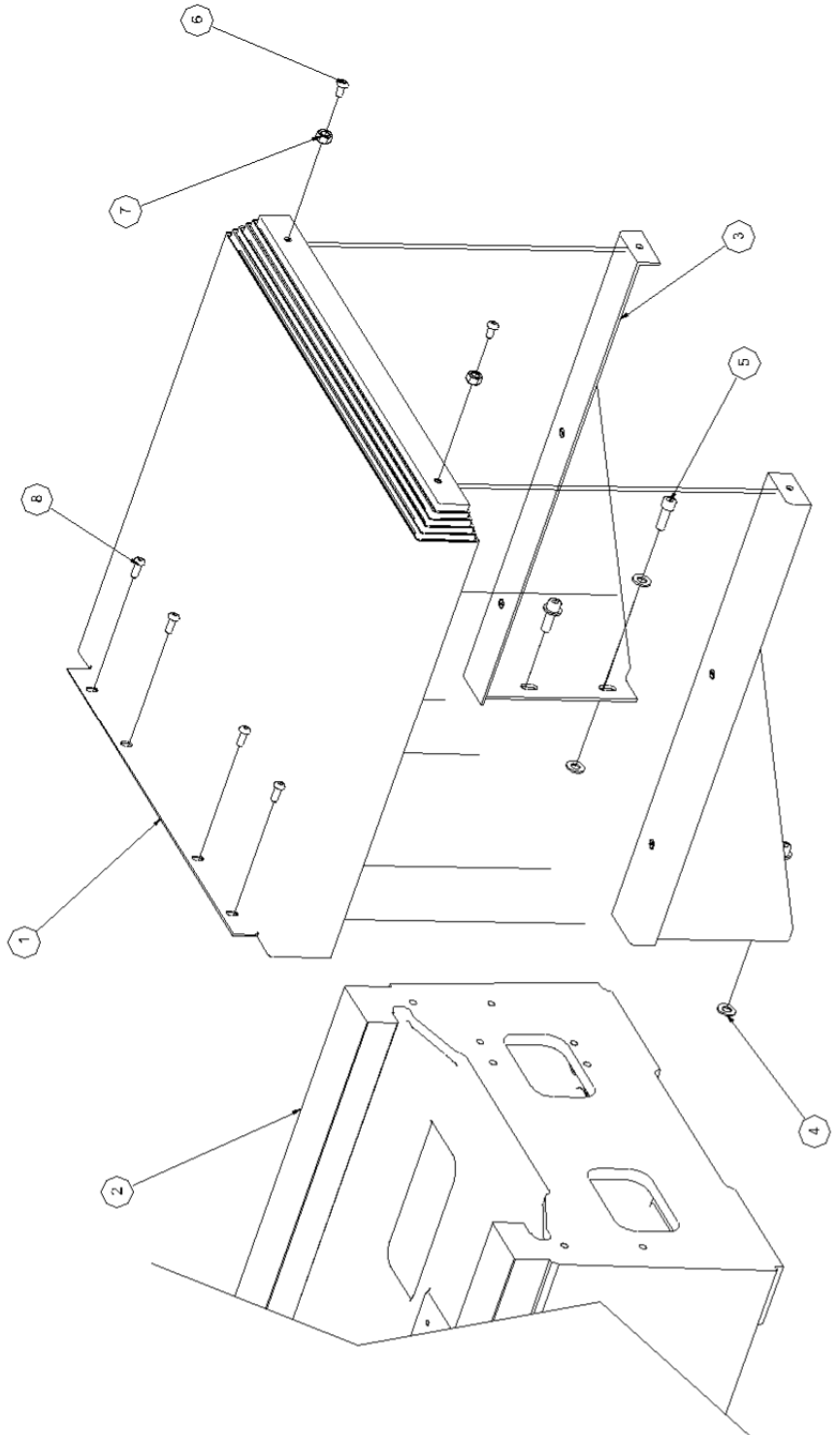

Column Drive Assembly:

Parts List			
ITEM	QTY	PART NUMBER	DESCRIPTION
1	1	Horizontal drive	
1.2	1	6098A	Mounting block, Left
1.3	1	6097A	Mounting Block, Right
1.5	4	ANSI B18.3 - 3/8 - 16 - 1	Hexagon Socket Head Cap Screw
1.6	1	6073R	Horizontal BallscREW
1.8	2	6049	Bearing Washer
1.9	2	6048	Bearing Nut
1.10	14	6037A	Belville Spring
1.11	2	9010A	Stop Bracket - F-90
1.12	8	ANSI B18.3 - 1/2 - 13 - 2	Hexagon Socket Head Cap Screw
1.13	2	ANSI B18.3 - 3/4 - 10 - 3	Hexagon Socket Head Cap Screw
1.14	4	ANSI B18.2.2 - 3/4 - 10	Hex Nut
1.15	3	9010C	Stop Rod - Column travel F-90
1.21	1	Aux air supply	
1.23	1	635TN	
1.26	2	6359D	
1.27	1	6359C	
1.31	10	514-7-75	Conduit Clamp 1/2"
1.32	1	air hose	
1.33	1	Parker Union Tee 1203P-2203P 1203P-4	1/4 npt Tee
1.34	1	502-11-16X	Quick Connect air Fitting Male
2	1	lower gear housing assy	
2.1	1	6104B	Housing
2.2	1	Hollow shaft	
2.8	1	648TG	Servo Motor
2.16	5	Legris pipe plug 16	
2.20	1	501-27	Oil Hole Cover
2.22	1	7192A	Bracket
2.24	1	514-4-17J	1/8" POLY X #10-32 STRAIGHT

REF90Y39-02132007

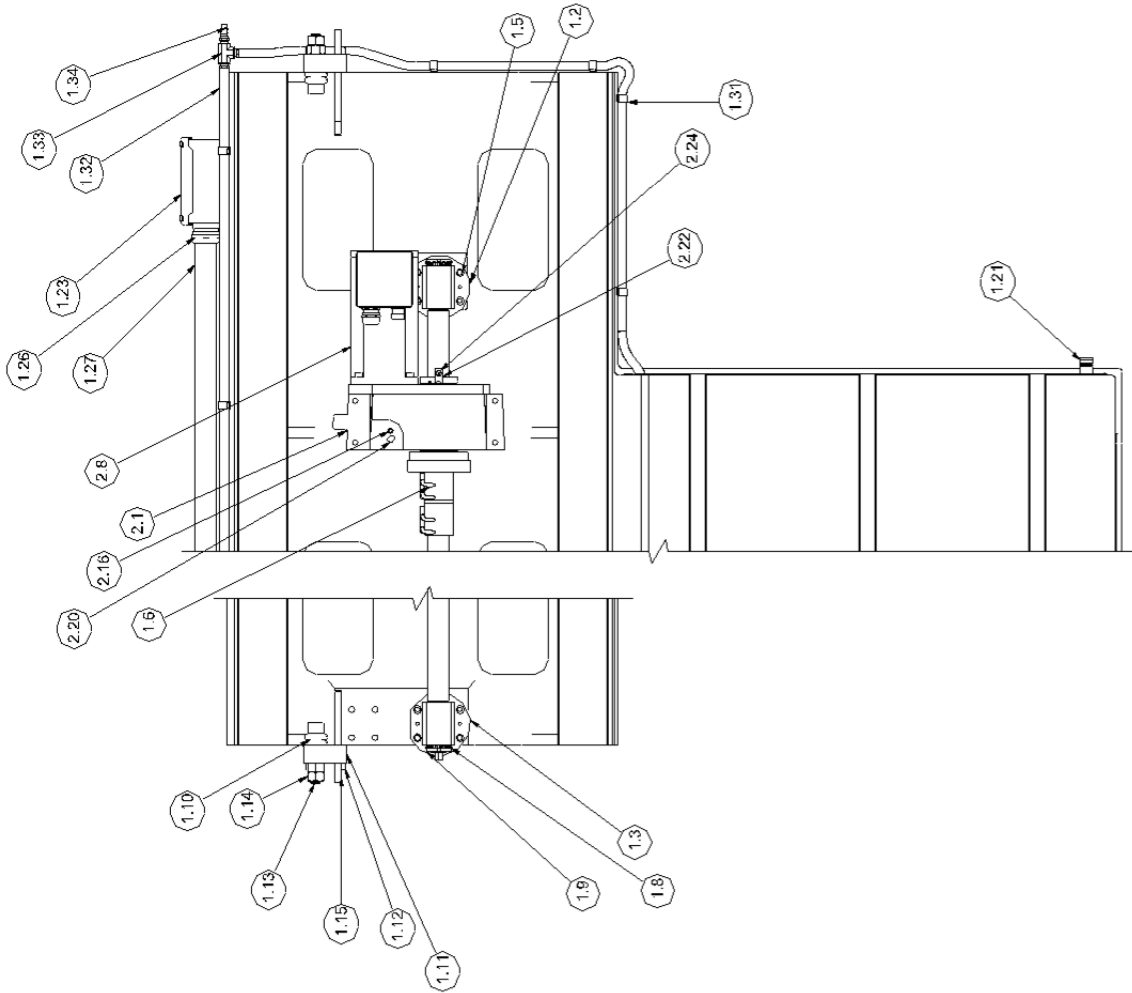

Horizontal End Stop Bumper Package:

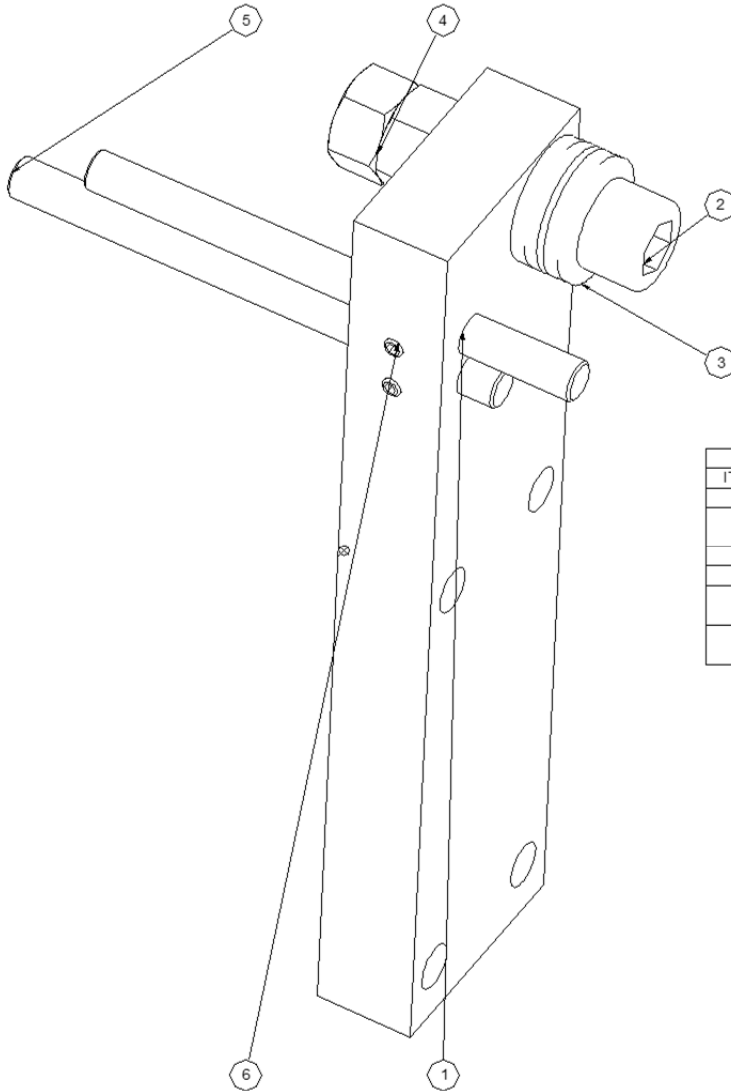

Parts List			
ITEM	QTY	PART NUMBER	DESCRIPTION
1	1	9010A	Stop Bracket - F-90
2	1	ANSI B18.3 - 3/4 - 10 UNC - 3	Hexagon Socket Head Cap Screw
3	7	6037A	Belville Spring
4	2	ANSI B18.2.2 - 3/4 - 10	Hex Nut
5	2	9010C	Stop Rod - Column travel F-90
6	2	ANSI B18.3 - 1/4-20 UNC x 0.38	Hexagon Socket Set Screw - Flat Point

REF90Y42-02142007

Column Drive Gear Housing:

Parts List			
ITEM	QTY	PART NUMBER	DESCRIPTION
1	1	6104B	Housing
2	1		Hollow shaft
3	1	6095	Bearing retainer
4	4	ANSI B18.3 - 3/8 - 16 - 5/8	Hexagon Socket Head Cap Screw
5	1	6093A	Driven gear Column feed F-8
6	1	6103	Bearing Lock Washer
7	1	6102	Bearing Lock Nut
8	1	6481G	Servo Motor
9	1	6105E	Cover, Housing
10	4	ANSI B18.3 - 5/16 - 18 - 1	Hexagon Socket Head Cap Screw
11	9	ANSI B18.3 - 5/16 - 18 - 3/4	Hexagon Socket Head Cap Screw
12	2	ANSI B18.8.2 - 5/16 x 7/8	Pin - Hardened Ground Production Dowel
13	1	6025E	Motor Pinion F-8 Column feed
14	2	ANSI B18.3 - 5/16-18 UNC x 0.31	Hexagon Socket Set Screw - Cup Point
15	1	6099A	Seal
16	5	Legris pipe plug 18	Seal
17	1	6100	Seal
18	1	6096	Wiper Retainer
19	3	ANSI B18.3 - 10-24 UNC x 0.32	Hexagon Socket Set Screw - Cup Point
20	1	501-27	Oil Hole Cover
21	1	6074J	Wiper kit
22	1	7192A	Bracket
23	1	Mf-87	Socket Button Head Cap Screw 10 - 24 x 1/4
24	1	514-4-17J	1/8 POLY X #10-32 STRAIGHT
25	1	ANSI B18.6.3 - 10 - 32	Hex Machine Screw Nut
26	1	6481H	Seal

REF90Y40-02132007

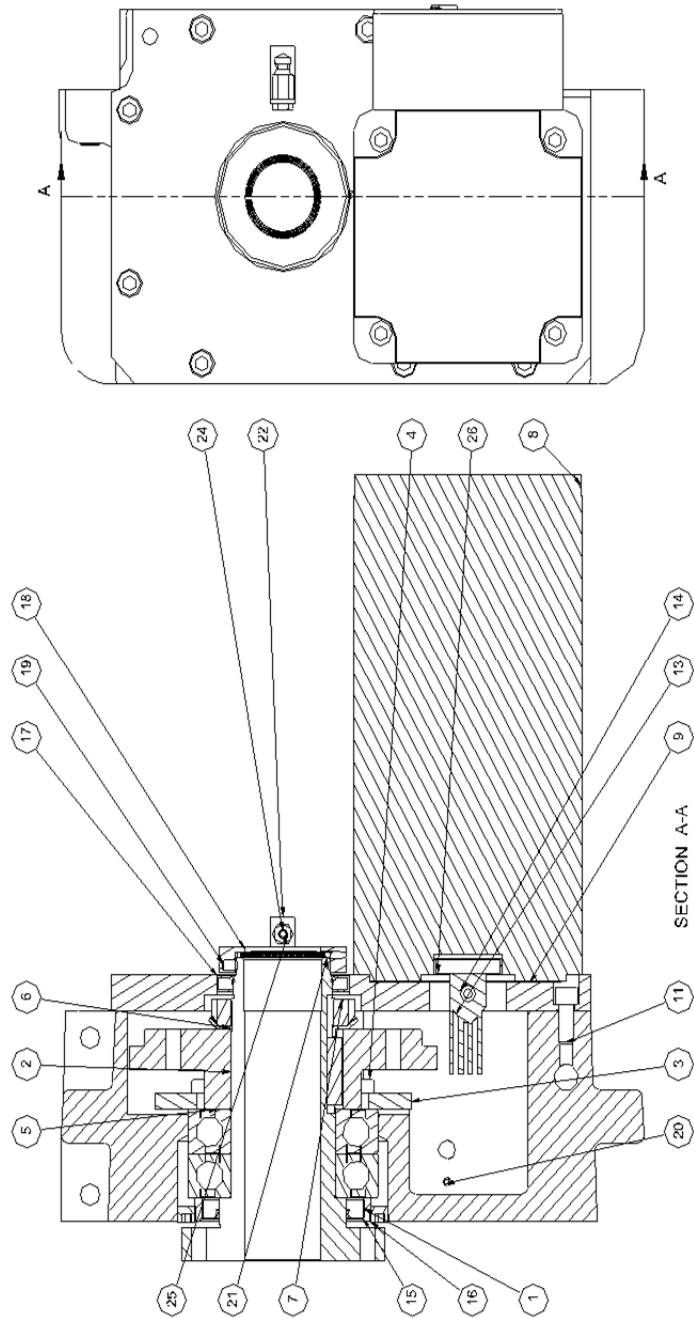

6580W Chip Shield Assembly:

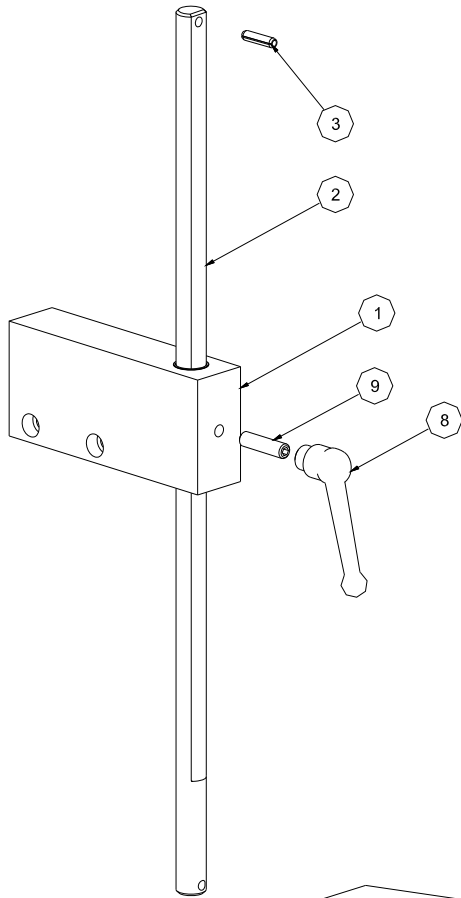

Chip Shield Assembly			
ITEM	QTY	PART NUMBER	DESCRIPTION
1	1	6580S	Mounting Bracket
2	1	6580T	Support Shaft
3	3	MF-226	Roll Pin
4	1	6580R	Chip Shield
5	1	6580Y	Plexiglass
6	4	Mf-88A	Button Head Cap Screw
7	4	MF-162	Hex Machine Screw Nut
8	1	7160F	Handle
9	1	MF-71E	Socket Set Screw

REF909Y41-02132007

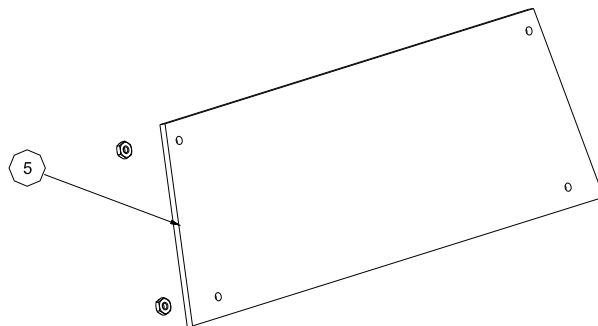
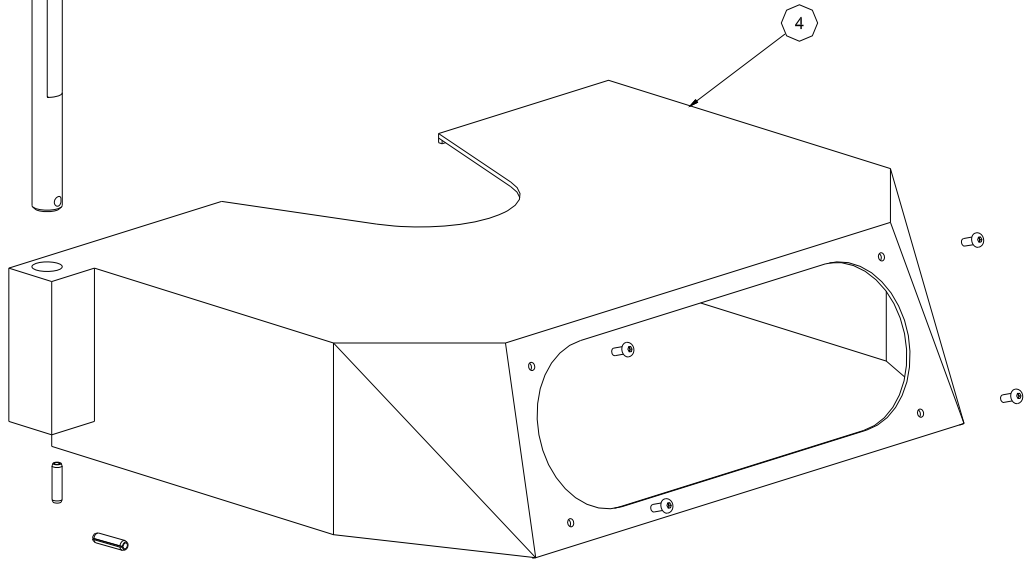

Material Safety Data Sheets

Mobil Vactra 2

2

Additional MSDS documents located on manual CD